

# Original Owner's Manual

# Jeep<sup>®</sup>

Standard Operating System with Hands Free Plowing Plows: HomePlow, Wingman, Drive Pro

Tailgate Spreaders: Base Line, Blaster

# Introduction

Meyer Products LLC has published this manual to help you get maximum performance from your Meyer Snow Plow and Spreader and familiarize you with the features designed for efficiency and safety; be sure you recognize and understand them. Follow recommended operation and maintenance instructions. Failure to do so may result in voiding your warranty.

DO NOT EQUIP ANY VEHICLE WITH A SNOW PLOW OR SPREADER WITHOUT CONSULTING MANUFACTURERS' RECOMMENDATIONS.

## Snow Plow Requirements

Vehicles with Meyer Snow Plows installed may be so equipped as to meet vehicle manufacturers' specifications and recommended options for snow plowing use. Most vehicle manufacturers insist that vehicles which are to be used for snow plowing be equipped with certain options and accessories, and it is so stated in vehicle manufacturer specifications for snow plow application.

**WARNING:** Deployment of an air bag while using a Meyer Snow Plow will not be covered under Meyer Products' warranty. We also recommend that, for optimum performance, vehicles used for snow plowing be equipped with:

- Four-Wheel Drive
- Minimum 60 Amp Alternator or larger
- Minimum 70 Amp Battery or larger (550 C.C.A.)
- Mud and Snow Tires
- Increased Radiator Cooling
- Automatic Transmission
- Power Brakes
- Power Steering

TORQUE CHART FOOT

Bolt Nut Size	Gr. 2	Gr. 5	Gr. 8
1/4-20	4-5		
5/16-18	9-11		
3/8-16	17-20	26-29	
7/16-14		42-46	60-66
1/2-13		64-72	99-100
5/8-11		127-141	179-198

## HomePlow Requirements

Vehicle requirements: Two or Four wheel drive SUV/Pick-up type vehicle 1/2 ton or smaller including Utility Vehicles. Use on vehicles greater than 1/2 ton is prohibited. Minimum 60 Amp alternator. Minimum 70 Amp Battery (550CCA/Cold Cranking Amps). Must be able to accept a front 2" category 3 receiver hitch. Front suspension must be able to handle 250 lbs. of added weight of plow and hitch. Stock vehicle with no suspension modifications (lift kits) that have modified the height of the vehicle.

**NOTE:** HomePlow shows all parts and installation instructions in this manual. For other models, please see their respective installation instructions.

Under the continuing Meyer Product Improvement Plan, Meyer Products LLC reserves the right to change design details and construction without prior notice and without incurring any obligation.

# Introduction

## Spreader Requirements

Vehicles equipped with Meyer spreaders installed may be so equipped as to meet vehicle manufacturers' specifications and recommended options for material spreading use. Most vehicle manufacturers insist that vehicles which are to be used for ice control be equipped with certain options and accessories, and it is so stated in vehicle manufacturer specifications for snow plow application.

Your spreader will come equipped with a cover that will protect your de-icing material from rain or snow; this can be removed simply by detaching the holding clamps on the sides of the hopper. Always replace cover after filling to prevent saturation of material from rain or snow.

WARNING: NEVER leave materials in hopper for long periods of time as de-icing materials will attract atmospheric moisture and may clump together.

CAUTION: Sweep area clear of foreign objects or obstacles that could cause personal injury. Keep other persons and animals out of area to be spread.

### For installation Base Line 240 & 400 series spreaders:

1. This product line can be installed on any vehicle with a class 3 hitch receiver that will accept a 2" square tube and has a tongue weight rating of at least 500 lbs (227 kg).
2. If your vehicle is not factory equipped with a hitch, we recommend taking it to a reputable trailer hitch installation shop or your vehicles dealership.

### For installation Base Line 750 series spreaders:

1. Due to the size and capacity of these spreaders we recommend installation on full size trucks with a 1/2 Ton rating or higher.
2. This product line can be installed on any vehicle with a class 3 hitch receiver that will accept a 2" square tube and has a tongue weight rating of at least 500 lbs (227 kg)
3. If your vehicle is not factory equipped with a hitch, we recommend taking it to a reputable trailer hitch installation shop or your vehicles dealership.

### For installation Blaster 350 series spreaders:

1. This product line can be installed on any vehicle with a class 3 hitch receiver that will accept a 2" square tube and has a tongue weight rating of at least 500 lbs (227 kg).
2. If your vehicle is not factory equipped with a hitch, we recommend taking it to a reputable trailer hitch installation shop or your vehicles dealership.

### For installation Blaster 750 series spreaders:

1. Due to the size and capacity of these spreaders we recommend installation on full size trucks with a 1/2 Ton rating or higher.
2. This product line can be installed on any vehicle with a class 3 hitch receiver that will accept a 2" square tube and has a tongue weight rating of at least 500 lbs (227 kg)
3. If your vehicle is not factory equipped with a hitch, we recommend taking it to a reputable trailer hitch installation shop or your vehicles dealership.

*As with any vehicle accessory, please refer to your owners manual to verify that the GVWR (Gross Vehicular Weight Rating) will not be exceeded, especially if this product will be used in conjunction with other mounted equipment. If equipment is mounted to vehicle with other than stock hardware or components, we the manufacturer cannot and will not be held responsible for damages. Also, check your vehicle owner's manual to be sure that the installation of "aftermarket" accessories will not void the manufacturers' factory warranty.*

# Plow Table of Contents

Introduction .....	2
Warranty & Registration .....	6-7
Safety Definitions & Warnings	
HomePlow .....	8-9
Plows .....	10-11
Safety Decals .....	14-15

## **HomePlow**

Component Identification .....	16-19
Assembly & Installation .....	20-23
Controller .....	24
Mounting & Dismounting .....	25-26
Hydraulics & Troubleshooting .....	27-28

## **Wingman & Drive Pro**

Pistol Grip Controller .....	29-31
Mounting & Dismounting	
2" Receiver .....	32-33
Drive Pro .....	34-35
EZ Plus .....	36-37
Hydraulics & Troubleshooting .....	38-41
Component Identification	
Wingman .....	42-43
Drive Pro .....	44-45
Maintenance	
General Maintenance .....	46-49
Vehicle Maintenance .....	50
Pre-Season Maintenance .....	51
Post-Season Maintenance .....	52
Snow Plow Storage .....	53
Warranty	
Plow .....	74-75
HomePlow .....	76
EC Declaration of Conformity .....	77

# Spreader Table of Contents

Introduction ..... 3  
Warranty & Registration ..... 6-7  
Safety Definitions & Warnings ..... 12-13

**Base Line**

Component Identification ..... 54-55  
Receiver Mount ..... 56  
Installation ..... 57  
Controller ..... 58-29

**Blaster**

Component Identification ..... 60-61  
Receiver Mount ..... 62-63  
Installation ..... 64  
Controller ..... 65

Maintenance ..... 66  
Troubleshooting ..... 67  
Calibration ..... 68-69

**Warranty**

Base Line ..... 70-71  
Blaster ..... 72-73

EC Declaration of Conformity ..... 77

# Warranty

Your operator's manual provides essential information on safety, operation, and maintenance. Failure to follow this operator's manual may result in damage to your equipment and affect your warranty.

Meyer's warranty covers manufacturing defects including welding, electrical, lights, controllers, and more.

The warranty does not cover abuse, misuse, bends, twists, paint, rust, corrosion, wear & tear, loss of time, incidentals, or similar issues.

For further information on the warranty, please review the pages 43 and 44.

All warranty work must be done by an authorized Meyer dealer. Your local dealer can be found by visiting...

[www.meyerproducts.com/dealer-locator](http://www.meyerproducts.com/dealer-locator)

## **Snow Plow Warranty**

Prior to use, please ensure your plow is registered. Registering your plow will upgrade your warranty\* from 2 years to 5 years\*\*.

## **Spreader Warranty**

Base Line and Blaster spreaders are both covered under the Meyer warranty.

- Base Line has a 2 year warranty\*\*\*
- Blaster has a 5 year warranty\*\*

\* The Home Plow comes with a 1 year warranty only and is not eligible for the extended 5 year warranty. Please hold onto proof of purchase to obtain warranty coverage.

\*\* Your plow and/or spreader must be registered to receive the extended 5 year warranty. If it is not registered within 60 days of purchase, you will receive a 2 year warranty.

\*\*\* Base Line comes with a 2 year warranty only and is not eligible for the extended 5 year warranty. Please hold onto proof of purchase to obtain warranty coverage.

# Registration

Please register all applicable spreader and plow models. Your dealer may have done this for you, if not you can register at the link below...

[www.meyerproducts.com/product-registration](http://www.meyerproducts.com/product-registration)

Please use the form below to note your registration information for future use.

If your product is not eligible for registration/extended warranty, please keep proof of purchase to present to your local dealer to obtain warranty coverage.

Registration ID \_\_\_\_\_

Purchase Date \_\_\_\_\_

Purchased From \_\_\_\_\_

Model \_\_\_\_\_

Mold Board Serial Number \_\_\_\_\_

Black Iron Serial Number \_\_\_\_\_

Spreader Serial Number \_\_\_\_\_

# Home Plow Safety Definitions & Warnings

## SAFETY DEFINITIONS



This is the safety alert symbol. It is used to alert you to potential personal injury hazards. Obey all safety messages that follow this symbol to avoid possible injury or death.



**DANGER** Indicates an imminently hazardous situation which, if not avoided, will result in death or serious injury.



**WARNING** Indicates a potentially hazardous situation which, if not avoided, could result in death or serious injury.



**CAUTION** Indicates a potentially hazardous situation which, if not avoided, may result in minor or moderate injury.

















**CAUTION** used without the safety alert symbol indicates a potentially hazardous situation which, if not avoided, will result in property damage.

H1	<b>DANGER</b>	Never stand or ride on the plow assembly. Keep people and pets at least 25 feet away from the snow plow when in operation. Failure to comply will result in death or serious injury.
H2	<b>DANGER</b>	Insert and lock locking pin securely before using. Not doing so will result in serious injury or death. It can also result in damage to the vehicle and/or plow.
H3	<b>WARNING</b>	Always lower moldboard to the ground when snow plow is being serviced or when vehicle is not in use. Failure to comply could result in death or serious injury.
H4	<b>WARNING</b>	The HomePlow is for driveway plowing only and should be used on ½-ton and smaller vehicles. Use of this product on larger than ½-ton vehicles is prohibited and can result in damage to the vehicle or plow. Failure to comply could result in death or serious injury.
H5	<b>WARNING</b>	NEVER use the HomePlow without first CAREFULLY reading the Owner's Manual. It is CRITICAL for your safety to ALWAYS obey EVERY warning in the manual and follow EVERY instruction EXPLICITLY. Failure to comply could result in death or serious injury.
H6	<b>WARNING</b>	The HomePlow by Meyer should be used by drivers with a valid operator's license. Keep all body parts inside the vehicle. Failure to comply could result in death or serious injury.
H7	<b>WARNING</b>	To prevent accidental movement of the plow, always turn off the controller whenever the plow is not in use. Failure to comply could result in death or serious injury.
H8	<b>WARNING</b>	The HomePlow should NEVER be used for ANY other purpose other than plowing snow on a driveway, using The HomePlow for other purposes could result in serious injury or death.
H9	<b>WARNING</b>	Inspect plow assembly and mounting components and fasteners for wear and damage before and after each use. Worn or damaged components or fasteners could allow the plow to drop unexpectedly. Failure to comply could result in death or serious injury.
H10	<b>WARNING</b>	Do not change plow position while traveling. You could suddenly lower the plow accidentally. Failure to comply could result in death or serious injury.
H11	<b>WARNING</b>	ALWAYS wear a seat belt when plowing snow. Hidden obstructions can cause the vehicle to stop suddenly resulting in personal injury. Failure to comply could result in death or serious injury.
H12	<b>WARNING</b>	Do not mix different kinds of hydraulic fluid. Some fluids are not compatible and may cause performance problems and product damage Failure to comply could result in death or serious injury.
H13	<b>WARNING</b>	NEVER perform any repairs or maintenance with the plow controller turned on and the plow plugged into the vehicle harness and the plow attached to the vehicle. Failure to comply could result in death or serious injury.
H14	<b>WARNING</b>	The vehicle must not be operated when overloaded. In all cases, the loaded vehicle weight, including the entire snow plow system, all aftermarket accessories, driver, passenger, options, nominal fluid levels, and cargo must not exceed the front/rear Gross Axle Weight Rating (GAWR), and total Gross Vehicle Weight Rating (GVWR). These weights ratings are specified on the safety compliance certification label on the driver's side door opening. The use of rear ballast weight may be required to prevent exceeding the front GAWR. Failure to comply could result in death or serious injury.
H15	<b>WARNING</b>	Read the HomePlow Owner's Manual before operating or servicing a snow plow. FOLLOW THESE INSTRUCTIONS EXPLICITLY. Failure to comply could result in death or serious injury.



# Home Plow Safety Definitions & Warnings

H16	 <b>WARNING</b>	SAFETY PRECAUTIONS should be used when Hydraulic Unit is in OPERATION and plow is in a RAISED position. Lower plow to ground when vehicle is PARKED in case of hydraulic failure. Failure to comply could result in death or serious injury.
H17	 <b>WARNING</b>	Remove Plow Assembly before placing vehicle on hoist/lift. Failure to comply could result in death or serious injury.
H18	 <b>WARNING</b>	Do not exceed 10 mph transporting plow. Do not exceed 5 mph plowing snow. Know your road conditions at all times. Keep feet clear of moldboard at all times. Failure to comply could result in death or serious injury.
H19	 <b>WARNING</b>	SAFETY PRECAUTIONS should be used when Hydraulic Unit is SERVICED. Hydraulic fluid under pressure can cause skin injection injury. If you are injured by hydraulic fluid, get medical attention immediately. Failure to comply could result in death or serious injury.
H20	 <b>WARNING</b>	Vehicle exhaust contains lethal fumes. Breathing these fumes, even in low concentrations, can cause death. Never operate vehicle in an enclosed area without venting the exhaust to the outside. Failure to comply could result in death or serious injury.
H21	 <b>WARNING</b>	Gasoline is highly flammable and gasoline vapor is explosive. Never smoke while working on vehicle. Keep all open flames away from gasoline tank and lines. Wipe up any spilled gasoline immediately. Failure to comply could result in death or serious injury.
H22	 <b>CAUTION</b>	Flag obstructions that are under snow to prevent damage to product or property. Failure to comply may result in minor or moderate injury.
H23	 <b>CAUTION</b>	A ballast weight may be required to prevent front GAWR overloading. If required, ballast must be securely attached at least 24 inches behind the rear axle. Failure to comply will result in property damage.
H24	 <b>CAUTION</b>	Batteries normally produce explosive gases which can cause personal injury. Therefore, do not allow flames, sparks or lit tobacco to come near the battery. When charging or working near a battery, always cover your face and protect your eyes, and also provide ventilation. Batteries contain sulfuric acid which burns skin, eyes and clothing. Failure to comply will result in property damage.
H25	 <b>CAUTION</b>	See your HomePlow Authorized Distributor/Web site for specific vehicle application recommendations before installation. Failure to comply will result in property damage.
H26	 <b>CAUTION</b>	Installation of a snow plow may affect your new vehicle warranty. For more information consult your Vehicle Owner's Manual / Vehicle Dealer. Failure to comply will result in property damage.
H27	 <b>CAUTION</b>	Warranty does not apply to a HomePlow product which has been negligently or improperly assembled or installed. Failure to comply will result in property damage.
H28	 <b>CAUTION</b>	<b>CAUTION:</b> To avoid harm to vehicles electrical system always disconnect battery before beginning installation. DO NOT BURN holes or WELD vehicle frame. This may cause frame failure. Failure to comply will result in property damage.
H29	 <b>CAUTION</b>	A driver's first responsibility is the safe operation of the vehicle and snow plow. The most important thing you can do to prevent a crash is to avoid distractions and pay attention to the road. Wait until it is safe to operate mobile communication equipment such as cell phones, two way radios, etc. Failure to comply will result in property damage.
H30	 <b>CAUTION</b>	Front end wheel alignment and headlight aim may require readjustment after installation of equipment, and is the responsibility of the equipment installer. Failure to adjust front wheel alignment may cause premature uneven tire wear. If required, reset to chassis manufacture's specifications. Failure to comply will result in property damage.

## SAFETY DEFINITIONS



This is the safety alert symbol. It is used to alert you to potential personal injury hazards. Obey all safety messages that follow this symbol to avoid possible injury or death.



**DANGER** Indicates an imminently hazardous situation which, if not avoided, will result in death or serious injury.



**WARNING** Indicates a potentially hazardous situation which, if not avoided, could result in death or serious injury.



**CAUTION** Indicates a potentially hazardous situation which, if not avoided, may result in minor or moderate injury.



**CAUTION** used without the safety alert symbol indicates a potentially hazardous situation which, if not avoided, will result in property damage.

# Plow Safety Definitions & Warnings

## SAFETY DEFINITIONS



This is the safety alert symbol. It is used to alert you to potential personal injury hazards. Obey all safety messages that follow this symbol to avoid possible injury or death.



**DANGER** Indicates an imminently hazardous situation which, if not avoided, will result in death or serious injury.



**WARNING** Indicates a potentially hazardous situation which, if not avoided, could result in death or serious injury.















**CAUTION** Indicates an potentially hazardous situation which, if not avoided, may result in minor or moderate injury.



**CAUTION** used without the safety alert symbol indicates a potentially hazardous situation which, if not avoided, will result in property damage.

1		Never stand or ride on the plow assembly. Keep people and pets at least 25 feet away from the snow plow when in operation. Failure to comply will result in death or serious injury.
2		Always lower moldboard to the ground when snow plow is being serviced or when vehicle is not in use. Failure to comply could result in death or serious injury.
3		NEVER use the Meyer plow without first CAREFULLY reading the Owner's Manual. It is CRITICAL for your safety to ALWAYS obey EVERY warning in the manual and follow EVERY instruction EXPLICITLY. Failure to comply could result in death or serious injury.
4		The Meyer plow should be used by drivers with a valid operator's license. Keep all body parts inside the vehicle. Failure to comply could result in death or serious injury.
5		The Meyer plow should NEVER be used for ANY other purpose other than plowing snow, using the Meyer plow for other purposes could result in serious injury or death.
6		Inspect plow assembly and mounting components and fasteners for wear and damage before and after each use. Worn or damaged components or fasteners could allow the plow to drop unexpectedly. Failure to comply could result in death or serious injury.
7		Do not change plow position while traveling. You could suddenly lower the plow accidentally. Failure to comply could result in death or serious injury.
8		ALWAYS wear a seat belt when plowing snow. Hidden obstructions can cause the vehicle to stop suddenly resulting in personal injury. Failure to comply could result in death or serious injury.
9		Do not mix different kinds of hydraulic fluid. Some fluids are not compatible and may cause performance problems and product damage Failure to comply could result in death or serious injury.
10		NEVER perform any repairs or maintenance with the plow controller turned on and the plow plugged into the vehicle harness and the plow attached to the vehicle. Failure to comply could result in death or serious injury.
11		The vehicle must not be operated when overloaded. In all cases, the loaded vehicle weight, including the entire snow plow system, all aftermarket accessories, driver, passenger, options, nominal fluid levels, and cargo must not exceed the front/rear Gross Axle Weight Rating (GAWR), and total Gross Vehicle Weight Rating (GVWR). These weights ratings are specified on the safety compliance certification label on the driver's side door opening. The use of rear ballast weight may be required to prevent exceeding the front GAWR. Failure to comply could result in death or serious injury.
12		Read the Meyer Plow Owner's Manual before operating or servicing a snow plow. FOLLOW THESE INSTRUCTIONS EXPLICITLY. Failure to comply could result in death or serious injury.
13		SAFETY PRECAUTIONS should be used when Hydraulic Unit is in OPERATION and plow is in a RAISED position. Lower plow to ground when vehicle is PARKED in case of hydraulic failure. Failure to comply could result in death or serious injury.
14		Remove Plow Assembly before placing vehicle on hoist/lift. Failure to comply could result in death or serious injury.
15		Do not exceed 40 mph transporting plow. Do not exceed 20 mph plowing snow. Know your road conditions at all times. Keep feet clear of moldboard at all times. Failure to comply could result in death or serious injury.

# Plow Safety Definitions & Warnings

16	 <b>WARNING</b>	SAFETY PRECAUTIONS should be used when Hydraulic Unit is SERVICED. Hydraulic fluid under pressure can cause skin injection injury. If you are injured by hydraulic fluid, get medical attention immediately. Failure to comply could result in death or serious injury.
17	 <b>WARNING</b>	Vehicle exhaust contains lethal fumes. Breathing these fumes, even in low concentrations, can cause death. Never operate vehicle in an enclosed area without venting the exhaust to the outside. Failure to comply could result in death or serious injury.
18	 <b>WARNING</b>	Gasoline is highly flammable and gasoline vapor is explosive. Never smoke while working on vehicle. Keep all open flames away from gasoline tank and lines. Wipe up any spilled gasoline immediately. Failure to comply could result in death or serious injury.
19	 <b>CAUTION</b>	Flag obstructions that are under snow to prevent damage to product or property. Failure to comply may result in minor or moderate injury.
20	 <b>CAUTION</b>	A ballast weight may be required to prevent front GAWR overloading. If required, ballast must be securely attached at least 24 inches behind the rear axle. Failure to comply will result in property damage.
21	 <b>CAUTION</b>	Batteries normally produce explosive gases which can cause personal injury. Therefore, do not allow flames, sparks or lit tobacco to come near the battery. When charging or working near a battery, always cover your face and protect your eyes, and also provide ventilation. Batteries contain sulfuric acid which burns skin, eyes and clothing. Failure to comply will result in property damage.
22	 <b>CAUTION</b>	See your Meyer plow Authorized Distributor/Web site for specific vehicle application recommendations before installation. Failure to comply will result in property damage.
23	 <b>CAUTION</b>	Installation of a snow plow may affect your new vehicle warranty. For more information consult your Vehicle Owner's Manual / Vehicle Dealer. Failure to comply will result in property damage.
24	 <b>CAUTION</b>	Warranty does not apply to a Meyer plow product which has been negligently or improperly assembled or installed. Failure to comply will result in property damage.
25	 <b>CAUTION</b>	CAUTION: To avoid harm to vehicles electrical system always disconnect battery before beginning installation. DO NOT BURN holes or WELD vehicle frame. This may cause frame failure. Failure to comply will result in property damage.
26	 <b>CAUTION</b>	A driver's first responsibility is the safe operation of the vehicle and snow plow. The most important thing you can do to prevent a crash is to avoid distractions and pay attention to the road. Wait until it is safe to operate mobile communication equipment such as cell phones, two way radios, etc. Failure to comply will result in property damage.
27	 <b>CAUTION</b>	Front end wheel alignment and headlight aim may require readjustment after installation of equipment, and is the responsibility of the equipment installer. Failure to adjust front wheel alignment may cause premature uneven tire wear. If required, reset to chassis manufacture's specifications. Failure to comply will result in property damage.
28	 <b>CAUTION</b>	The Meyer Products' electrical and hydraulic system contains several automotive style fuses. If a problem should occur and fuse replacement is necessary, the replacement fuse must be of the same type and amperage rating as the original. Installing a fuse with a higher rating can damage the system and could cause a fire.

## SAFETY DEFINITIONS



This is the safety alert symbol. It is used to alert you to potential personal injury hazards. Obey all safety messages that follow this symbol to avoid possible injury or death.



**DANGER** Indicates an imminently hazardous situation which, if not avoided, will result in death or serious injury.



**WARNING** Indicates a potentially hazardous situation which, if not avoided, could result in death or serious injury.



**CAUTION** Indicates a potentially hazardous situation which, if not avoided, may result in minor or moderate injury.



**CAUTION** used without the safety alert symbol indicates a potentially hazardous situation which, if not avoided, will result in property damage.

# Spreader Safety Definitions & Warnings

## SAFETY DEFINITIONS



This is the safety alert symbol. It is used to alert you to potential personal injury hazards. Obey all safety messages that follow this symbol to avoid possible injury or death.

### DANGER

DANGER Indicates an imminently hazardous situation which, if not avoided, will result in death or serious injury.

### WARNING

WARNING Indicates a potentially hazardous situation which, if not avoided, could result in death or serious injury.

### CAUTION













CAUTION Indicates a potentially hazardous situation which, if not avoided, may result in minor or moderate injury.

### CAUTION

CAUTION used without the safety alert symbol indicates a potentially hazardous situation which, if not avoided, will result in property damage.

1	DANGER	<b>NEVER</b> stand or ride on the spreader. Failure to comply will result in death or serious injury.
2	DANGER	Keep hands, feet, and clothing away from power driven parts. Failure to comply will result in death or serious injury.
3	DANGER	Make sure spreader is completely shut off and all movement has stopped before attempting to clean, service or unplug. Failure to comply will result in death or serious injury.
4	DANGER	<b>NEVER</b> enter hopper while spreader is operating or capable of being operated. Failure to comply will result in death or serious injury.
5	WARNING	<b>NEVER</b> operate or service your spreader without first CAREFULLY reading the Owner's Manual. It is CRITICAL for your safety to ALWAYS obey EVERY warning in the manual and follow EVERY instruction EXPLICITLY. Failure to comply could result in death or serious injury.
6	WARNING	Never leave operator's position without first completely turning off spreader, disengaging PTO, shutting off hydraulic valve and setting vehicle parking brake. Failure to comply will result in death or serious injury.
7	WARNING	Never operate spreader without all shields, guards, and safety decals in place. Failure to comply will result in death or serious injury.
8	WARNING	Spreader should only be operated by personnel trained in the safe use and transportation of this equipment.
9	WARNING	The spreader should <b>NEVER</b> be used for any other purpose other than spreading ice melting or traction products on streets, parking lots and driveways. Failure to comply will result in property damage, death or serious injury.
10	WARNING	Inspect spreader assembly and mounting components and fasteners for wear and damage before and after each use. Worn or damaged components or fasteners could allow spreader to break free from the transport vehicle. Failure to comply will result in death or serious injury.
11	WARNING	Transport vehicle must not be operated when overloaded. In all cases, the loaded vehicle weight, including the entire spreader system, all aftermarket accessories, driver, passenger, options, nominal fluid levels, and cargo must not exceed the front/rear Gross Axle Weight Rating (GAWR), and total Gross Vehicle Weight Rating (GVWR). These weights ratings are specified on the safety compliance certification label on the driver's side door opening. Failure to comply will result in death or serious injury.
12	WARNING	Spreader may tip over or fall. Spreader should be solidly supported when being mounted, dismounted, moved, or stored. Failure to comply will result in death or serious injury.
13	WARNING	Operator, bystanders and pets should be kept at least 50 feet away from spreader during operation. Failure to comply will result in death or serious injury.
14	WARNING	<b>SAFETY PRECAUTIONS</b> should be used when hydraulic system is operating or being serviced. Hydraulic fluid under pressure can cause a skin injection injury. If you are injured by hydraulic fluid, get medical attention immediately. Failure to comply will result in death or serious injury.
15	WARNING	Engine exhaust contains lethal fumes. Breathing these fumes, even in low concentrations, can cause death. Never operate engine in an enclosed area without venting the exhaust to the outside. Failure to comply will result in death or serious injury.

# Spreader Safety Definitions & Warnings

16	 <b>WARNING</b>	Gasoline is highly flammable and gasoline vapor is explosive. Never smoke while working on vehicle or spreader. Keep all open flames away from gasoline tank and lines. Wipe up any spilled gasoline immediately. Failure to comply will result in death or serious injury.
17	 <b>WARNING</b>	<b>NEVER</b> operate the spreader gasoline engine without first <b>CAREFULLY</b> reading the Owner's Manual. It is <b>CRITICAL</b> for your safety to <b>ALWAYS</b> obey <b>EVERY</b> warning in the manual and follow <b>EVERY</b> instruction <b>EXPLICITLY</b> . Failure to comply will result in death or serious injury.
18	 <b>CAUTION</b>	A driver's first responsibility is the safe operation of the vehicle and spreader. The most important thing you can do to prevent a crash is to avoid distractions and pay attention to the road. Wait until it is safe to operate mobile communication equipment such as cell phones, two way radios, etc. Failure to comply will result in injury.
19	 <b>CAUTION</b>	Vehicle must conform to all local, state, and national regulations regarding the use of reflective markings and flashing lights. Failure to comply will result in injury.
20	 <b>CAUTION</b>	Batteries normally produce explosive gases which can cause personnel injury. Therefore, do not allow flames, sparks or lit tobacco to come near the battery. When charging or working near a battery, always cover your face and protect your eyes, and also provide ventilation. Batteries contain sulfuric acid which burns skin, eyes, and clothing. Failure to comply will result in injury.
21	 <b>CAUTION</b>	Never transport spreader with spinner in the raised position. Failure to comply will result in property damage.
22	 <b>CAUTION</b>	Installation of a Meyer spreader may affect your new vehicle warranty. Before beginning spreader installation verify mounting method is acceptable to your vehicle manufacturer. Failure to comply will result in property damage.
23	 <b>CAUTION</b>	Warranty does not apply to a Meyer spreader product which has been negligently or improperly assembled or installed. Failure to comply will result in property damage.
24	 <b>CAUTION</b>	<b>CAUTION:</b> To avoid harm to vehicles electrical system always disconnect battery before beginning installation. <b>DO NOT</b> BURN holes or WELD vehicle frame. This may cause frame failure. Failure to comply will result in property damage.
25	 <b>CAUTION</b>	<b>CAUTION:</b> To avoid harm to spreader electrical system always disconnect battery before beginning installation or service. Do not operate spreader with a missing, discharged or dead battery. Failure to comply will result in property damage.
26	 <b>CAUTION</b>	The Meyer spreader electrical system contains several automotive style fuses. If a problem should occur and fuse replacement is necessary, the replacement fuse must be of the same type and amperage as the original. Installing a fuse with a higher rating can damage the system and could cause a fire. Failure to comply will result in property damage.
27	 <b>CAUTION</b>	Spreader is not designed to be chassis mounted. Do not support spreader by body jacks alone. Spreader must be installed directly onto truck bed. Failure to comply will result in property damage.

## SAFETY DEFINITIONS



This is the safety alert symbol. It is used to alert you to potential personal injury hazards. Obey all safety messages that follow this symbol to avoid possible injury or death.



**DANGER** Indicates an imminently hazardous situation which, if not avoided, will result in death or serious injury.



**WARNING** Indicates a potentially hazardous situation which, if not avoided, could result in death or serious injury.



**CAUTION** Indicates a potentially hazardous situation which, if not avoided, may result in minor or moderate injury.



**CAUTION** used without the safety alert symbol indicates a potentially hazardous situation which, if not avoided, will result in property damage.

# Plow Safety Decals



In addition to following local speed laws, it is important to understand the additional weight of a plow can increase the time it takes your vehicle to stop. DO NOT exceed 40 mph while transporting the plow or 20 mph while plowing. Lower speeds accordingly when faced with additional restrictions due to the elements, traffic, or otherwise.

A snow plow has many moving parts. Please keep hands and feet clear while operating the plow.

# Spreader Safety Decals

These safety alert decals are used to alert you of potential personal injury hazards. Obey all safety messages that follow this symbol to avoid possible injury or death.



**DANGER Conveyor**  
This decal alerts all to the danger of serious personal injury or death while servicing or cleaning this equipment without first turning off or disconnecting all power sources.



**CAUTION**  
This decal cautions all to observe general safety procedures when operating, moving, storing, cleaning or servicing this equipment.



**DANGER Spinner**  
This decal alerts all to the danger of any person being near the spinner while it is turning where serious personal injury could result if struck by flying debris.



**CAUTION Empty Hopper**  
This decal cautions all to only lift or move equipment when hopper is empty to prevent the risk of serious personal injury or property damage.



**CAUTION**  
This decal cautions all to the risk of the tank containing hazardous chemicals. Operators should wear appropriate PPE when contact with chemicals is possible.



**CAUTION Fork Length**  
This decal cautions all to make sure fork lift arms extend a minimum of 4" (10.2cm) past both brackets before lifting or moving equipment to prevent the risk of serious personal injury or property damage.

# Component Identification: Model 76000

Parts indented are included in the assembly under which they are indented.

ITEM	PART #	QTY	DESCRIPTION	Item	Part #	Qty	DESCRIPTION	Item	Part #	Qty	DESCRIPTION
	16609	1	• PAF/LIFT FRAME ANGLING	19	22427	1	.... HOSE ASSEMBLY SAE 6	37	20309	1	.... LOCKNUT 5/8-11
	13145	1	.. LIFT FRAME & HYDRAULIC ASSY	20	05028	1	.... MOTOR SOLENOID	38	22816	2	.... PIVOT PIN 1/2" X 3"
1	13095	1	... A-FRAME	21	05026	1	.... POWER CABLE	39	22820	1	.... FIXED ANGLE PIN
2	13129	1	... REAR COVER	22	05027	1	.... MOTOR SOLENOID GROUND WIRE	40	22845	2	.... HAIR PIN 1/8" X 1- 5/16"
3	13130	1	... LIFT FRAME		08258	1	.. PLOW PARTS CARTON	41	20307	3	.... LOCKNUT 1/2-13
4	13142	1	... LIFT ARM	23	07650	1	... DUAL COMPRESSION SPRING RAM	42	22821	4	.... COVER FASTENER
5	20027	2	... BOLT 5/16-18 X 1" GR. 2	24	13146	2	... CART PIVOT BRACKET		09325J	1	.. MOLDBOARD & PIVOT ASSY
6	20326	2	... LOCKWASHER 5/16"	25	13147	1	... CART JACK BRACKET	43	09124	2	... EYE BOLT KIT
7	20352	2	... FLATWASHER 5/16"	26	15134	2	... QUART M-1 HYDRAULIC FLUID	44	09323	1	... CUTTING EDGE
8	20355	3	... FLATWASHER 1/2"	27	15636	1	... FRONT COVER	45	12978	2	... TRIP SPRING
9	20420	2	... COTTER PIN 1/4" X 2"	28	22818	3	... PLOW CART CASTER	46	13110	1	... PIVOT BAR
10	22436	2	... PIN 1" X 3"	29	22823	1	... VEHICLE SIDE HARNESS	47	13125	1	... HP-6"8" MOLDBOARD
11	22816	3	... PIVOT PIN 1/2" X 3"	30	22825	1	... VEHICLE SIDE HARNESS EXT	48	20307	6	... LOCKNUT 1/2-13
12	22821	4	... COVER FASTENER	31	22826	1	... AUTO ANGLING CONTROLLER	49	20357	2	... FLATWASHER 5/8"
13	22845	3	... HAIR PIN 1/8" X 1- 5/16"		08245	1	... MOUNTING HARDWARE BAG	50	20385	2	... COTTER PIN 1/8" X 1-1/4"
14	09917	1	... PLOW MARKER KIT	32	11101	1	.... HINGE PIN	51	21943	6	... BOLT 1/2-13 X 1-3/4" GR. 5
15	13854	1	... POWER ANGLING HYD UNIT	33	20152	1	.... BOLT 5/8-11 X 5" GR. 5	52	22720	2	... PIVOT PIN 5/8 X 7"
16	22460	2	.... 90 DEGREE ELBOW SAE 6	34	20355	6	.... FLATWASHER 1/2"	53	08107J	1	• Deflector Kit
17	05816	1	.... LIFT CYLINDER 1" X 6" SAE 6	35	21984	4	.... HAIRPIN COTTER				
18	22822	1	.... PLOW SIDE HARNESS	36	22083	1	....LYNCH PIN				



# Component Identification: Model 76000

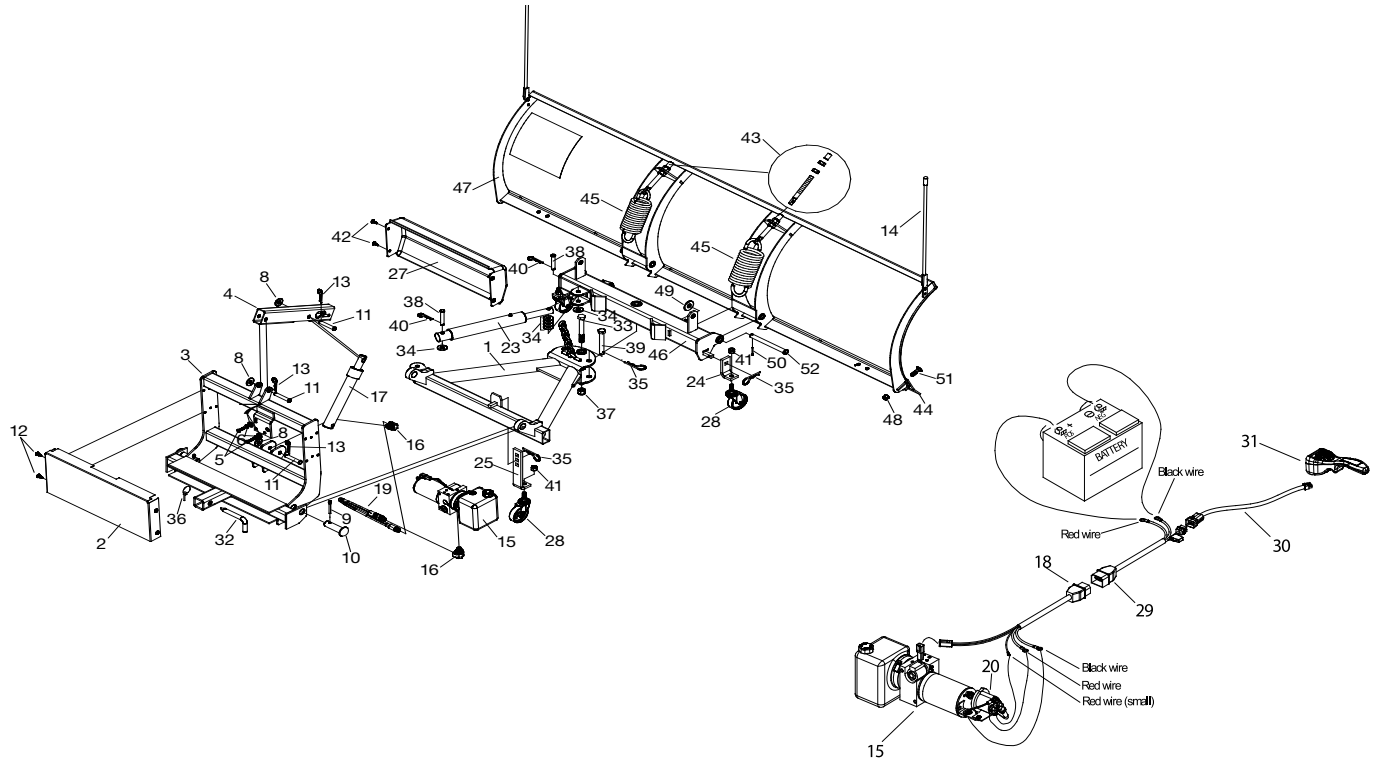

# Component Identification: 13854 Auto Angling Hydraulic

Parts indented are included in the assembly under which they are indented.

ITEM	PART #	QTY	DESCRIPTION
1	N/A	1	• BASE ASSY.
2	N/A	1	• PUMP ASSY.
3	N/A	4	• 1/4-20 X 1-1/4" SOCKET HEAD CAP SCREW
4	N/A	2	• 1/4 X 3/4" DOWEL PIN
5	N/A	1	• INTERMEDIATE SHAFT
6	15145	1	• HOSE CLAMP 2-9/16" - 3-1/2"
7	15067	1	• RESERVOIR BREATHER
8	15148	1	• CHECK VALVE CARTRIDGE
9	15149	1	• "S2" CARTRIDGE VALVE
10	15146	1	• "S1" CARTRIDGE VALVE
11	15150	2	• "S1" & "S2" COIL
12	05029	1	• MOTOR SOLENOID
13	15144	1	• RESERVOIR
14	N/A	1	• ORIFICE PLUG
15	15143	1	• MOTOR 12VDC
16	N/A	1	• MOTOR SOLENOID MOUNTING BRACKET
17	N/A	1	• MOTOR SOLENOID MOUNTING PLATE
18	N/A	2	• 10-24 X 3/8" SELF TAPPING SCREW
19	05026	1	• POWER CABLE 5"
20	N/A	1	• RETURN TUBE

ITEM	PART #	QTY	DESCRIPTION
21	N/A	1	• STREET ELBOW 3/8" NPT BLACK PIPE
22	N/A	1	• SUCTION TUBE
23	15101	1	• FILTER SCREEN
24	N/A	2	• 10-32 X 7/16" HEX/WASHER SCREW
25	05030	1	• POWER CABLE 9"

# Component Identification: 13854 Power Angling Hydraulic

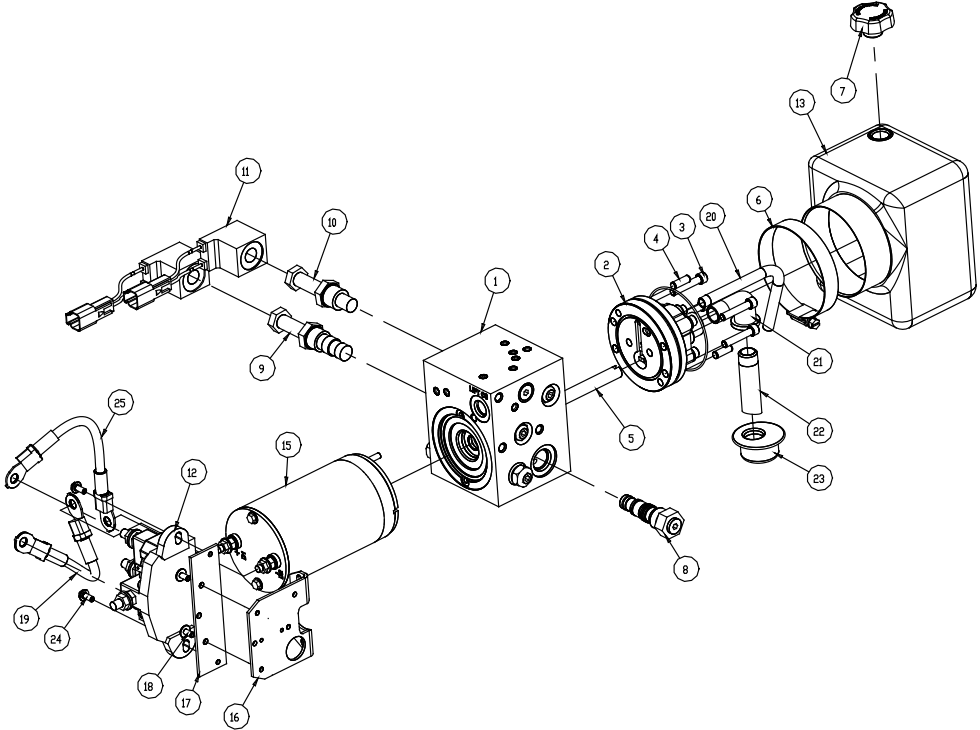

# HomePlow Assembly & Installation

## STEP 1

Attach the two wheel assemblies with the shorter brackets to either side of the plow pivot bar and the third wheel assembly to the Lift Frame Assembly under the lifting cylinder.

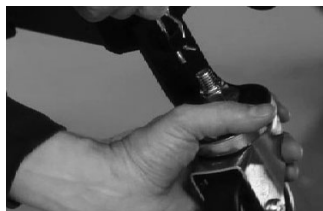

## STEP 2

Install Plow Markers to each side of the plow using 5/16-18 x 1" bolt, 5/16 flatwashers and 5/16-18 locknut as shown below.



# HomePlow Assembly & Installation

## STEP 3

Carefully route the Vehicle Harness to the vehicle battery (fig. 1). You may need to route thru the grille or behind/under the bumper. Be sure to stay away from hot, sharp or moving parts of the vehicle and use the zip ties provided to secure. Attach the Black wire to the negative (-) battery post (fig. 2) and the red wire to the positive (+) battery post (fig. 3).

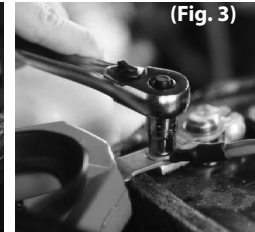
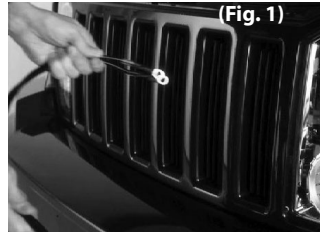

## STEP 4

Carefully attach the Vehicle Harness Extension to the vehicle harness (fig. 4) and route extension into the vehicle. For wireless remote control models, plug receiver box and secure with zip ties (fig. 5). The extension can either be routed thru the firewall (fig. 6) or along the hood channel (fig. 7) and thru the window or door jamb (fig. 8). Be sure to stay away from hot, sharp or moving parts of the vehicle and use the zip ties provided to secure. If routing thru window or door make sure the hood, door or window closes without pinching or cutting the harness. Connect the Controller to the Harness Extension (fig. 9).

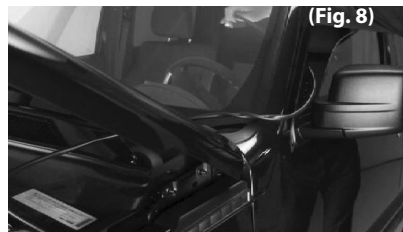

# HomePlow Assembly & Installation

## STEP 5

Install your Receiver Hitch Mount (sold separately) per manufacturers instructions. Measure center of square hitch to the ground. This dimension (A) should be a minimum of 10" and a maximum of 13" (fig. 10). Measure from the hitch pin hole to the very end of your bumper. This dimension (B) should be not more than 8-1/2". If your dimension does not fall within these ranges you should contact your hitch dealer/manufacturer for height or length adjustment accessories.

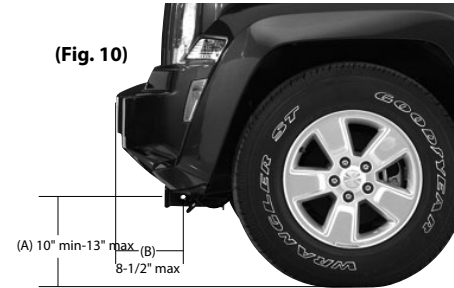

## STEP 6

Gently roll the plow to the receiver hitch on the vehicle so that the male tube on the lift frame is lined up directly in front of the receiver hitch (fig. 11). Lift slightly on the "Lift Here" decal (fig. 12) and push plow assembly into the vehicle receiver hitch until the pin holes align. Proper install is shown in fig. 13.

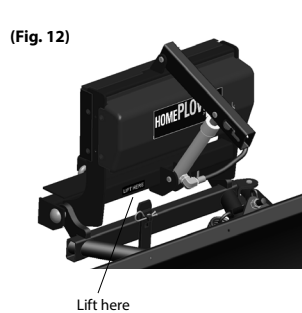
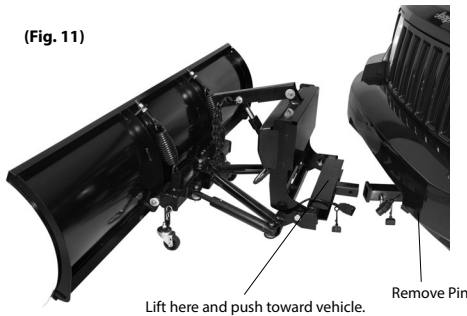

# HomePLOW Assembly & Installation

## STEP 7

Remove both weather covers from the ends of the Plow Harness and Vehicle Harness, add dielectric grease to the connecting prongs, and connect (fig. 14).

## STEP 8

Raise plow and reposition the two front wheel brackets 180 degrees (fig.15) and the one rear wheel bracket 90 degrees (fig. 16) for plowing mode.

## STEP 9

Raise and lower (and angle left & right if equipped with power angling) plow 10 times to automatically purge the air out of the hydraulic system. Lower plow to ground and turn off controller. Check fluid level in hydraulic unit and top off if necessary (fig. 18). Attach Hydraulic Cover to Hydraulic Assembly Lift Frame using two Cover fasteners on each side (fig. 19). The cover fasteners are locked in place when the center nail of the cover fastener is pushed in.

## STEP 10

The chain is adjustable at the lift arm. The chain must be adjusted with the controller in the down (Float) position and the lift cylinder must be pushed down as far as it will go. The chain should be adjusted to have 2-3 links of slack (fig. 20). Also if a major hydraulic malfunction is experienced the plow can be raised by a floor jack or two people and the chain can be adjusted up with no slack. This will then suspend the plow above ground so the vehicle can be driven to your nearest HomePLOW Service center.

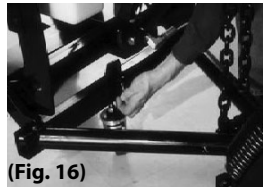
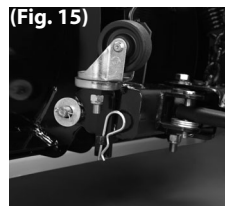

# HomePlow Controller Operation

Turn the controller on by holding down the on/off switch until the controller lights up (1 second). To raise the plow press the up arrow.

To angle the plow left press the left arrow and to angle the plow right press the right arrow. The plow can be lowered by pressing the lower (down) arrow.

If the lower button is pressed for more than 1 second the plow will go into Float. Float position will keep the S1 valve energized which will allow the plow to remain in contact with the ground regardless of grade. Pressing the raise arrow will take the plow out of Float and will not allow the plow to lower automatically when encountering a different grade.

The controller has timers built in for safety. The plow will only raise continually for 4 seconds at a time and angle left or right continually for 6 seconds at a time. The controller will automatically shut down the function being used if the timer values (4 seconds for raise and 6 seconds for angle) are exceeded.

In order to reset simply release the function being pressed and this will reset the timer and controller. Make sure controller is turned off when plow is not in use.-

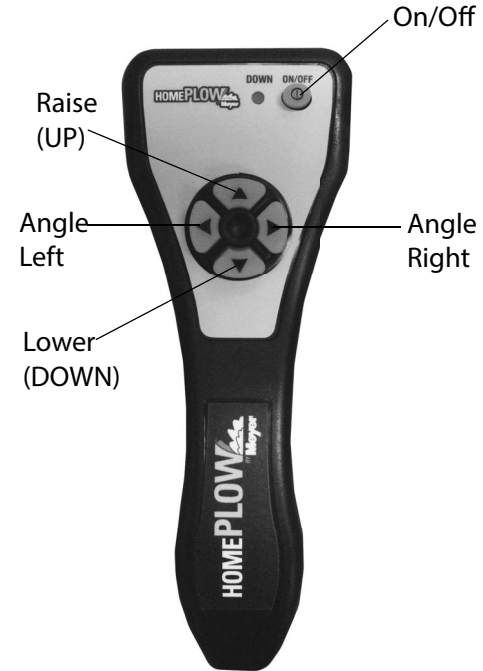



# HomePlow Mounting to Vehicle

Remove Hitch Pin.

Gently roll the plow to the receiver hitch on the vehicle so that the male tube on the lift frame is lined up directly in front of the receiver hitch (fig. 20).

Lift slightly on the “Lift Here” decal (fig. 20) and push plow assembly into the vehicle receiver hitch until the pin holes align (fig. 20).

Connect electrical plug (fig. 21) and raise plow to turn all three plow wheels to the plowing position (fig 22).

(Fig.20)



(Fig. 21)



(Fig. 22)

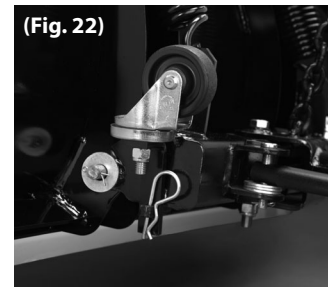

# HomePlow Dismounting from Vehicle

Raise plow and set wheels to storage position (fig. 23).

Lower plow all the way down and put the controller into "Float" position.

Push down on lift arm to put slack into the lift chain (fig. 24).

Disconnect electrical plug and install weather covers to both end of the harness.

Remove Hitch pin (fig. 25). Gently lift at "Lift Here" decal (fig. 25) and slide Lift Frame out of receiver hitch on vehicle (fig. 25).

Re-install Hitch pin thru Lift Frame.



(Fig.25)



# HomePlow Troubleshooting

Condition	Possible Cause	Correction
Plow does not lift or lifts slowly - motor operates	<ol style="list-style-type: none"> <li>1. Low hydraulic fluid level</li> <li>2. Discharged batter</li> <li>3. Leaking or open "S1" cartridge</li> <li>4. Motor turning counter clockwise</li> <li>5. Malfunctioning hydraulic unit</li> </ol>	<ol style="list-style-type: none"> <li>1. Add fluid to proper level</li> <li>2. Recharge battery</li> <li>3. Clean or replace "S1" cartridge</li> <li>4. Check wiring to motor solenoid (T1 should be energized) - check controller - replace motor solenoid</li> <li>5. Replace hydraulic unit</li> </ol>
Plow angles right when raise switch is pressed	<ol style="list-style-type: none"> <li>1. Leaking or open "S2" cartridge</li> <li>2. Wiring not correct</li> <li>3. Bad controller</li> </ol>	<ol style="list-style-type: none"> <li>1. Clean or replace "S2" cartridge</li> <li>2. Check wiring harness</li> <li>3. Replace controller</li> </ol>
Motor doesn't operate	<ol style="list-style-type: none"> <li>1. Check red and black wires at battery</li> <li>2. No current to motor solenoid (small red wire T1 &amp; small black wire T2)</li> <li>3. Malfunctioning motor solenoid</li> <li>4. Malfunctioning motor</li> <li>5. Malfunctioning hydraulic unit</li> </ol>	<ol style="list-style-type: none"> <li>1. Clean and tighten connection</li> <li>2. Locate malfunction and repair (check controller)</li> <li>3. Replace motor solenoid</li> <li>4. Replace motor</li> <li>5. Replace hydraulic unit</li> </ol>
Plow doesn't lower	<ol style="list-style-type: none"> <li>1. No current to "S1" coil (black with white stripe &amp; white wire)</li> <li>2. "S1" cartridge jammed in closed position</li> <li>3. Inoperative "S1" coil (black with white stripe &amp; white wire)</li> </ol>	<ol style="list-style-type: none"> <li>1. Locate malfunction and repair (check controller)</li> <li>2. Replace "S1" cartridge</li> <li>3. Replace "S1" coil (black with white strip &amp; white wire)</li> </ol>

# HomePlow Troubleshooting

Condition	Possible Cause	Correction
Plow creeps down	<ol style="list-style-type: none"> <li>1. Leaking "S1" cartridge</li> <li>2. Leaking Raise Cylinder, hose, or fitting</li> </ol>	<ol style="list-style-type: none"> <li>1. Clean or replace "S1" cartridge</li> <li>2. Replace Raise Cylinder, hose, or fitting</li> </ol>
Plow does not angle left	<ol style="list-style-type: none"> <li>1. No current to "S2" coil (orange &amp; black w/ white stripe wire)</li> <li>2. Motor turning clockwise</li> <li>3. Bad "S2" valve</li> </ol>	<ol style="list-style-type: none"> <li>1. Locate malfunction and repair</li> <li>2. Check wiring of motor solenoid (T2 should be energized) - check controller - replace motor solenoid</li> <li>3. Replace "S2" valve</li> </ol>
Plow does not angle right	<ol style="list-style-type: none"> <li>1. No current to "S2" coil (orange &amp; black w/ white stripe wire)</li> <li>2. Motor turning counter clockwise</li> <li>3. Bad "S2" valve</li> </ol>	<ol style="list-style-type: none"> <li>1. Locate malfunction and repair</li> <li>2. Check wiring of motor solenoid (T1 should be energized) - check controller - replace motor solenoid</li> <li>3. Replace "S2" valve</li> </ol>

Function	Motor Solenoid	S1	S2
Raise	X (T1 RED)		
Lower		X	
Left	X (T2 BLACK)		X
Right	X (T1 RED)		X

# Pistol Grip Controller Operation

The snow plow should only be in operation when the vehicle ignition switch and the controller are in the "ON" position. Care should be taken to insure that the controller is kept dry and free from moisture during normal operation. When operating the snow plow lights the vehicle headlight switch must be turned to the park position so the vehicle headlights and snow plow lights are not on at the same time.

By tapping the ON/OFF button once, it will turn ON the snow plow lights low beam only. The plow will be OFF. The ON/OFF button will illuminate AMBER. By tapping the ON/OFF button again, it will turn OFF the plow lights and the controller illumination.

When the ON/OFF button is continuously depressed for more than 1 second, it will turn ON the plow controller and the low beams of the snow plow lights. Tapping the ON/OFF button again will turn on the high beams of the snow plow lights and the MONITOR light will turn BLUE to show the plow lights are in the high beam position.

The ON/OFF button , when tapped, will toggle between low and high beam for the plow lights. Note that the plow lights will not turn on if the vehicle's headlights are on.

By continuously depressing the ON/OFF button a second time for more than 1 second, it will turn OFF the plow controller and the GREEN controller illumination. Plow lights will turn off once the vehicle ignition is turned off.

The controller buttons will illuminate GREEN showing the location of the individual buttons for the functions of the snow plow.

Lowering of the snow plow in small increments at a time is possible by tapping the down arrow in short intervals. Holding down the down arrow will activate a float light located in the upper right corner of the controller. This light indicates the snow plow is now in the Float position. In this position the snow plow will be able to follow the contour of the road and the snow plow can also be angled to the left or right. Touching the up arrow automatically cancels the Float position.

If the directional button, while angling or raising the snow plow, is pressed for more than six seconds the operation will be cancelled. This feature eliminates unnecessary amp draw from the vehicle charging system.

By double tapping any button quickly, the controller will automatically move the plow to that position then stop.

Reset the controller is accomplished by turning off the vehicle ignition. If the monitor light is still illuminated after attempts to reset the controller have failed, contact your nearest authorized Meyer dealer for repairs.

# Pistol Grip Controller Features

## Hands-Free Plowing or ALM/ARM

When activated, the Hands-Free Plowing (HFP) mode uses the vehicle's shift lever to control the up/down movement of the moldboard. Pressing the HFP button on the controller will toggle you through: On/Off, Back-drag Mode (default mode when active), and Forward Plowing Mode.

## Back-dragging Mode or ALM

When the controller is on and you are in the conventional plow control mode, pressing the HFP button will activate Hands-Free Plowing (HFP). The default mode for HFP is the Back-drag Mode. In the Back-drag Mode, the moldboard will automatically lower when you put the vehicle in reverse. Put the vehicle in drive to automatically raise the moldboard.

## Forward Plowing Mode or ARM

To activate the Forward Plowing Mode when HFP is already on, press the HFP button once. The moldboard will automatically lower when you put the truck into drive. When you reach the end of a run, the moldboard will automatically raise when you put the vehicle in reverse. To turn the HFP feature off, press the HFP button until you see the HFP light go off.

# Pistol Grip Controller Diagnostics

## Self Diagnosing

This switch is self diagnosing. The monitor light is located in the upper left corner next to the float light of the control switch. When the monitor light turns on and begins to flash the control switch is sensing a problem with a specific coil/wire color on the hydraulic unit.

The controller offers diagnostics imprinted on the backside of the controller, which can be seen below, for easy identification of which solenoid or coil may be creating the error.

Use the chart below to determine the correlation between light flashes and respective coil/wire color on the hydraulic unit.

Continuous	Motor Solenoid
1 Light Flash	Red
2 Light Flashes	Black
3 Light Flashes	Green
4 Light Flashes	Yellow
5 Light Flashes	Light Blue
6 Light Flashes	Purple

# Pistol Grip Controller Identification



**Straight Blade Controller**

Provides up, down, with left and right angling using the directional pad.

Includes models: Wingman, Drive Pro, Lot Pro, Road Pro, and Diamond Edge

# 2" Receiver Quick Link Mounting System – Mount/ON

Note: Images may vary based on model

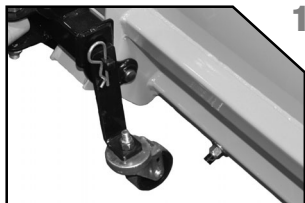

1. Push the plow towards the vehicle using the wheels.

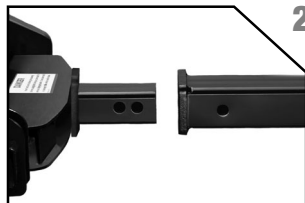

2. Align the 2" receiver and mount the plow using the pin to lock it in place.



3. Adjust crankstand until it is no longer in contact with the ground.



4. Remove crankstand from a-frame.



5. Attach crankstand to lift frame.



6. Remove weather covers and connect both electrical plugs.



# 2" Receiver Quick Link Mounting System – Dismount/OFF

Note: Images may vary based on model



1

1. Press down button until Float light turns Blue/on.



2

2. Push lift arm down until there is a little slack in the chain.

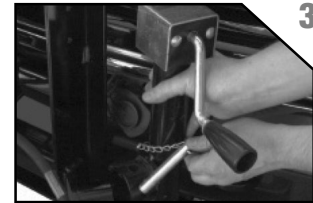

3

3. Remove crankstand from lift frame.



4

4. Attach crankstand to a-frame..

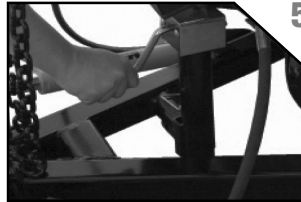

5

5. Adjust crankstand until crankstand comes into contact with the ground and then turn 1 to 2 revolutions.

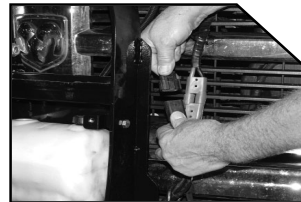

7

7. Disconnect both electrical plugs and install weather cover on both ends.

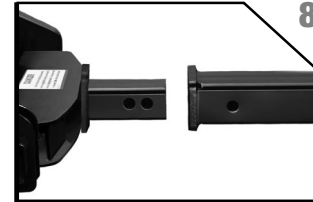

8

8. Pull the pin from the receiver hitch to unlock the mount and back the vehicle away from the plow.

# Drive Pro Mounting System – Mount/ON

Note: Images may vary based on model



1. Pull vehicle into plow assembly and push plow assembly forward an inch or two.

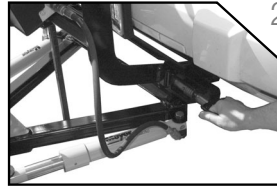

2. Twist handle on driver side to disengage the notch that locks open the pins.



3. Push back on lift frame until pins spring thru mount on vehicle.

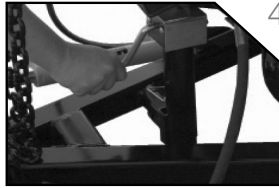

4. Adjust crankstand until it is no longer in contact with the ground.



5. Remove crankstand from a-frame.

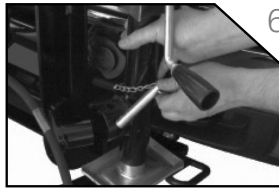

6. Attach crankstand to lift frame.

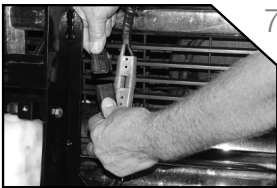

7. Remove weather covers and connect both electrical plugs.

# Drive Pro Mounting System – Dismount/OFF

Note: Images may vary based on model



1. Press down button until Float light turns Blue/on.

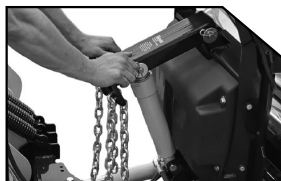

2. Push lift arm down until there is a little slack in the chain.



3. Remove crankstand from lift frame.



4. Attach crankstand to a-frame..



5. Adjust crankstand until crankstand comes into contact with the ground and then turn 1 to 2 revolutions.

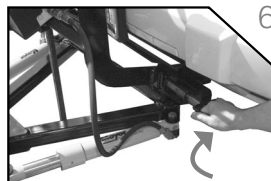

6. Pull handle on driver's side to disengage pins then twist until the notch locks the pins in the open position.



7. Disconnect both electrical plugs and install weather cover on both ends.



8. Back vehicle away from plow assembly.

# EZ Plus Mounting System – Mount/ON

Note: Images may vary based on model

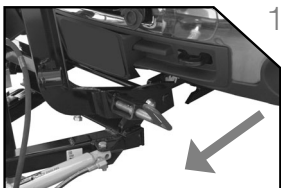

1. Pull vehicle into plow assembly and push plow assembly forward an inch or two.



2. Twist handles on both sides to engage spring loaded pins.



3. Push back on lift frame until pins spring thru mount on vehicle.



4. Adjust crankstand until it is no longer in contact with the ground.



5. Remove crankstand from A-frame.

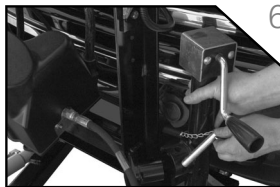

6. Attach crankstand to lift frame.



7. Remove weather covers and connect both electrical plugs.

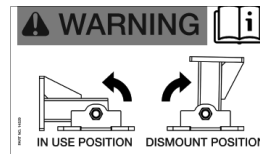

**NOTE: FOR SV3 PLOWS ONLY**  
Please note that the SV3 A-Frame is equipped with a flip-up support bracket to be utilized when dismantling the plow. This support bracket needs to be in the UP position prior to removing the plow from the vehicle to prevent the lift frame from falling forward. The support bracket must be in the DOWN position while the plow is in use.



# EZ Plus Mounting System – Dismount/OFF

Note: Images may vary based on model

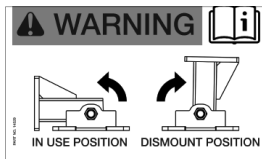

**NOTE: FOR SV3 PLOWS ONLY**  
Please note that the SV3 A-Frame is equipped with a flip-up support bracket to be utilized when dismantling the plow. This support bracket needs to be in the UP position prior to removing the plow from the vehicle to prevent the lift frame from falling forward. The support bracket must be in the DOWN position while the plow is in use.



1. Press down button until Float light turns Blue/on.



2. Push lift arm down until there is a little slack in the chain.



3. Remove crankstand from lift frame.



4. Attach crankstand to A-frame.



5. Adjust crankstand until crankstand comes into contact with the ground, then turn 1 to 2 revolutions.

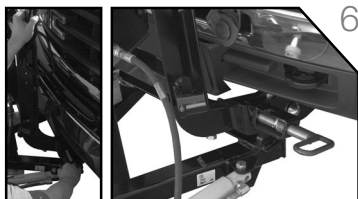

6. While slightly pushing the lift frame towards vehicle, pull handles on either side to disengage pins then twist until the leg locks the pin in the open position.

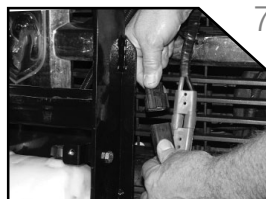

7. Disconnect both electrical plugs and install weather cover on both ends.



8. Back vehicle away from plow assembly.

**SAFETY PRECAUTIONS**  
SEE PAGES 8-13 FOR DEFINITIONS

**⚠ DANGER** 6

**⚠ WARNING**

**⚠ CAUTION**

**CAUTION** 27

# E-73 HYDRAULIC COMPONENT IDENTIFICATION

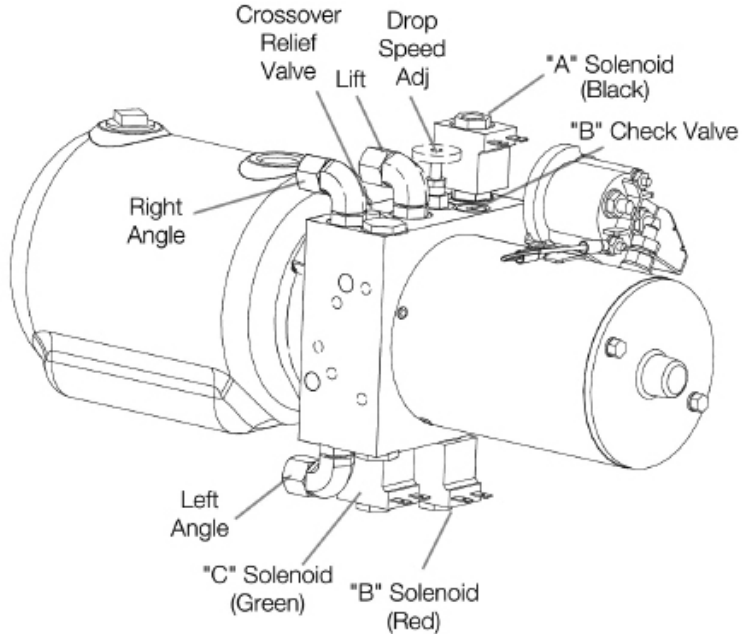

E-73	Raise	Lower	Angle Right	Angle Left
Motor	X		X	X
A Valve		X		
B Valve	X			
C Valve			X	

# E-73 Hydraulics Testing Tips

**Before any troubleshooting is started, make certain the following conditions are met.**

1. The moldboard is pointing straight ahead. If the unit is disabled, this can often be done by connecting the hose from the left cylinder into the right cylinder and pushing the snow plow by hand.
2. Check to ensure the power angling cylinders are installed correctly.
3. The solenoid coils must be on their proper valve: the “C”- coil (green and brown wire), the “B”-coil (red and brown wire) and the “A” coil (black and brown wire).
4. The electrical installation must have been made according to installation instructions supplied by Meyer Products LLC.

## Testing

Many tests do not require removing the Power Unit from the vehicle. However, more thorough testing can be done by using the Meyer Test Stand (available at Authorized Servicing Dealers) which allows direct pressure and Amperage readings.

1. Use a screwdriver or other small tool to check for magnetism of solenoid coils “A”, “B” & “C”. Place the tool on the side of the coil and have an assistant operate the switch. You should feel magnetic attraction.
2. Use a test light or volt meter to determine whether there is power at harness or switches. (The wire must be probed)
3. When determining Amp draw of motor, always obtain the highest value possible, i.e., at maximum raise or angle with motor running.
4. Proper rotation for motor is indicated by an arrow on the top of the pump.
5. The pump shaft (all models) of a good pump can be turned smoothly using two fingers. If it cannot be turned easily, the pump is too tight and must be replaced.
6. Pump pressure can be measured at an angle hose (note pressure at full angle) or in the pressure filter port (an adapter is necessary for the filter port).
7. If hydraulic system is contaminated with oil or a substance other than Meyer Hydraulic Fluid, it is recommended that the hydraulic unit, power angling rams and hoses be drained and flushed clean with Meyer M-2 Flush Fluid. The system should then be refilled with Meyer M-1 Fluid.

# E-73 Hydraulics Troubleshooting Guide

These charts are intended to be used as an aid in diagnosing Meyer Hydraulic Power Units. They are not a substitute for factory training and experience. Be certain to read the General Information and Testing Tips sections before attempting any troubleshooting. Additional detailed information as well as all electrical schematics may be found in Service Manuals at [www.meyerproducts.com](http://www.meyerproducts.com).

CONDITION	POSSIBLE CAUSE	CORRECTION
Plow does not lift or lifts slowly - motor operates	<ol style="list-style-type: none"> <li>1. Low hydraulic fluid level.</li> <li>2. Discharged battery.</li> <li>3. Leaking or open "A" cartridge.</li> <li>4. No current to "B" coil. (red and brown wire)</li> <li>5. Inoperative "B" coil. (red and white or black wire)</li> <li>6. Malfunctioning motor.</li> <li>7. Malfunctioning pump.</li> </ol>	<ol style="list-style-type: none"> <li>1. Add fluid to proper level</li> <li>2. Recharge battery.</li> <li>3. Clean or replace "A" cartridge.</li> <li>4. Locate malfunction and repair.</li> <li>5. Replace "B" coil. (red and brown wire)</li> <li>6. Repair or replace motor.</li> <li>7. Replace pump.</li> </ol>
Plow does not angle right - motor operates	<ol style="list-style-type: none"> <li>1. Mechanical bind or interference.</li> <li>2. No current to "C" coil. (green and white or black wire)</li> <li>3. Inoperative "C" coil. (green and white or black wire)</li> <li>4. Inoperative "C" cartridge.</li> <li>5. Leaking crossover relief valve.</li> </ol>	<ol style="list-style-type: none"> <li>1. Eliminate mechanical bind or interference.</li> <li>2. Locate malfunction and repair.</li> <li>3. Replace "C" coil. (green and brown wire)</li> <li>4. Clean or replace "C" cartridge.</li> <li>5. Replace crossover relief valve.</li> </ol>
Plow does not angle left - motor operates	<ol style="list-style-type: none"> <li>1. Mechanical bind or interference.</li> <li>2. Malfunctioning coupler. (if equipped)</li> <li>3. Leaking crossover relief valve.</li> </ol>	<ol style="list-style-type: none"> <li>1. Eliminate mechanical bind or interference.</li> <li>2. Repair or replace coupler.</li> <li>3. Replace crossover relief valve.</li> </ol>
Plow does not angle - motor operates	<ol style="list-style-type: none"> <li>1. Mechanical bind or interference.</li> <li>2. Leaking crossover relief valve.</li> </ol>	<ol style="list-style-type: none"> <li>1. Eliminate mechanical bind or interference.</li> <li>2. Replace crossover relief valve.</li> </ol>



# E-73 Hydraulics Troubleshooting Guide

These charts are intended to be used as an aid in diagnosing Meyer Hydraulic Power Units. They are not a substitute for factory training and experience. Be certain to read the General Information and Testing Tips sections before attempting any troubleshooting. Additional detailed information as well as all electrical schematics may be found at [www.meyerproducts.com](http://www.meyerproducts.com).

CONDITION	POSSIBLE CAUSE	CORRECTION
Plow will not hold in angled position	<ol style="list-style-type: none"> <li>1. Air in cylinders and hoses.</li> <li>2. Leaking dual pilot check valve.</li> <li>3. Leaking crossover relief valve.</li> <li>4. Crossover relief valve opening at too low a pressure.</li> </ol>	<ol style="list-style-type: none"> <li>1. Bleed cylinders and hoses.</li> <li>2. Replace pilot check valve.</li> <li>3. Replace crossover relief valve.</li> <li>4. Replace crossover relief valve.</li> </ol>
Motor does not operate	<ol style="list-style-type: none"> <li>1. Discharged or defective battery.</li> <li>2. Loose/corroded electrical connections.</li> <li>3. Inoperative starter solenoid.</li> <li>4. Malfunctioning control switch.</li> <li>5. Malfunctioning motor.</li> </ol>	<ol style="list-style-type: none"> <li>1. Recharge or replace battery.</li> <li>2. Clean and tighten electrical connections.</li> <li>3. Replace starter solenoid.</li> <li>4. Replace control switch.</li> <li>5. Repair or replace motor.</li> </ol>
Plow does not lower	<ol style="list-style-type: none"> <li>1. No current to "A" coil. (black and brown wire)</li> <li>2. "A" cartridge jammed in closed position.</li> <li>3. Inoperative "A" coil. (black and brown wire)</li> </ol>	<ol style="list-style-type: none"> <li>1. Locate malfunction and repair.</li> <li>2. Clean or replace "A" cartridge.</li> <li>3. Replace "A" coil. (black and brown wire)</li> </ol>
Plow creeps down	<ol style="list-style-type: none"> <li>1. Leaking "A" cartridge.</li> <li>2. Leaking "A" cartridge O-ring.</li> <li>3. Leaking "B" check valve.</li> <li>4. Leaking Ram Packing Cup.</li> <li>5. Leaking O-ring at bottom of lift cylinder.</li> </ol>	<ol style="list-style-type: none"> <li>1. Clean or replace "A" cartridge.</li> <li>2. Replace O-ring.</li> <li>3. Clean or replace "B" check valve.</li> <li>4. Replace Ram Packing Cup.</li> <li>5. Replace O-ring.</li> </ol>

# Wingman Component Identification\*

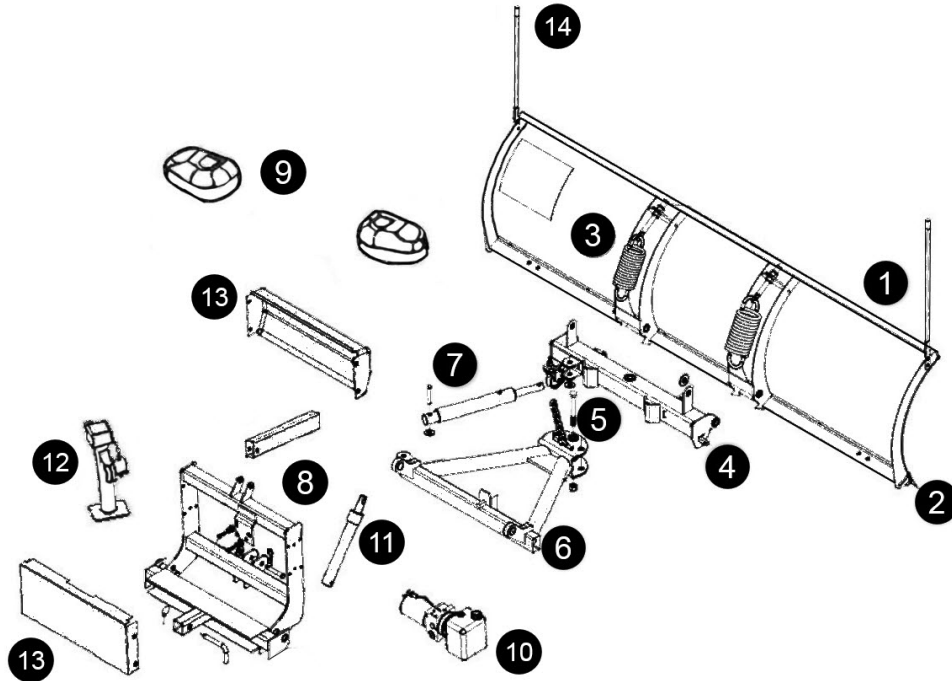

\*Image is a general representation of a Straight Blade model. Your specific model may appear differently, but the components are the same.

# Wingman Component Identification

- 1. Moldboard** – Steel moldboard sheet is impact and corrosion resistant.
- 2. Cutting Edge** – Replaceable high carbon steel provides extra long operating life; should be 1/2" above ground in plowing position. (Can be higher when used on gravel driveways.) Available in Urethane or Rubber.
- 3. Trip Springs** – Allow moldboard to trip forward and ride over obstructions, this protects the snow plow, vehicle, and operator.
- 4. Pivot Bar** – Heavy-duty highway plow design provides durability with three push/connect points to the moldboard.
- 5. King Bolt** – Heavy-duty high grade bolt that attaches A-Frame to the Pivot Bar.
- 6. A-Frame** – Designed to attach the snow plow to the vehicle, to pivot moldboard for angle plowing, and to hold plow at proper distance in front of vehicle.
- 7. Power Angling Cylinders** – Heavy-duty winter specified hydraulics to move the plow left or right.
- 8. Lift Frame** – Allows for fast, complete removal of front end hardware, snow plow, lights and hydraulic unit in one complete module.
- 9. Meyer Nite Saber® Snow Plow Lights** – Complies with the Federal Motor Vehicle Safety Standards.
- 10. Hydraulic Power Unit** - Operates snow plow hydraulically- raises, lowers, angles, holds and floats moldboard in plowing position.
- 11. Lift Cylinder** – Lifts and lowers moldboard.
- 12. Crankstand** – Positions Moldboard and Lift Frame for easy attaching and detaching. Adjusts plow height in varying ground conditions for easy mount/dismount.
- 13. Hydraulic Cover** - Protects the Hydraulic Power Unit from debris and elements.
- 14. Plow Markers** – Attach to corner of moldboard providing line of site to the operator.

# Drive Pro Component Identification\*

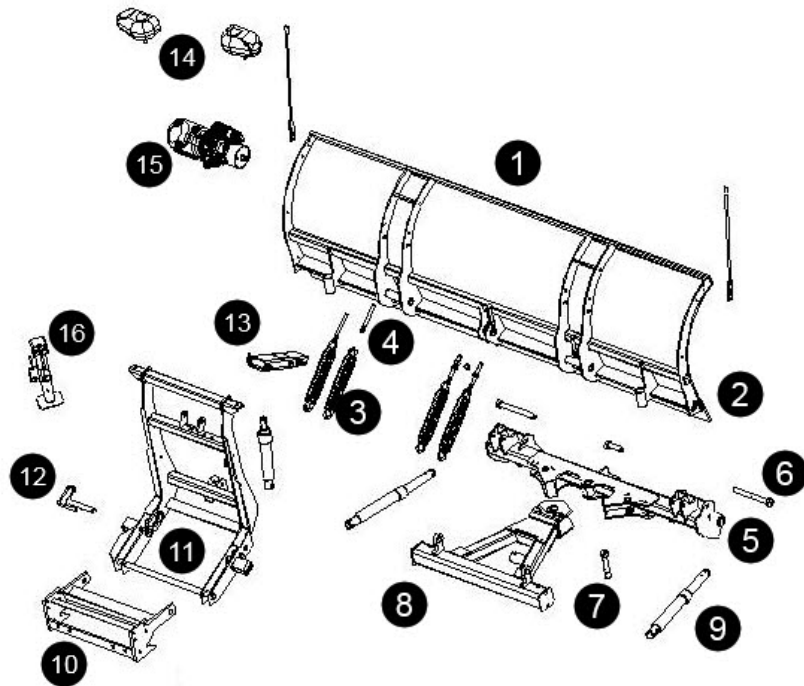

\*Image is a general representation of a Straight Blade model. Your specific model may appear differently, but the components are the same.

# Drive Pro Component Identification

- 1. Moldboard** – Steel or Polyethylene moldboard sheet is impact and corrosion resistant.
- 2. Cutting Edge** – Replaceable high carbon steel provides extra long operating life; should be 1/2" above ground in plowing position. (Can be higher when used on gravel driveways.) Available in Urethane or Rubber.
- 3. Trip Springs** – Allow trip edge to trip back and ride over obstructions, this protects the snow plow, vehicle, and operator.
- 4. Eye Bolts** – Adjusts Trip Spring to their proper tension (coils should just begin to separate).
- 5. Pivot Bar** – Heavy-duty highway plow design provides durability with three push/connect points to the moldboard.
- 6. Pivot Pin** – Pin that secures the moldboard to the Pivot Bar.
- 7. King Bolt** – Heavy-duty high grade bolt that attaches A-Frame to the Pivot Bar.
- 8. A-Frame** – Designed to attach the snow plow to the vehicle, to pivot moldboard for angle plowing, and to hold plow at proper distance in front of vehicle.
- 9. Power Angling Cylinders** – Heavy-duty winter specified hydraulics to move the plow left or right.
- 10. Clevis Frame** – Allows snow plow assembly to be attached or detached from vehicle in minutes.
- 11. Lift Frame** – Allows for fast, complete removal of front end hardware, snow plow, lights and hydraulic unit in one complete module.
- 12. Dual Pin Dismount System** – Pull handle to release plow system for easy on/off.
- 13. Lift Cylinder** – Lifts and lowers moldboard.
- 14. Meyer Nite Saber® Snow Plow Lights** – Complies with the Federal Motor Vehicle Safety Standards.
- 15. Hydraulic Power Unit** – Operates snow plow hydraulically- raises, lowers, angles, holds and floats moldboard in plowing position.
- 16. Crankstand** – Positions Moldboard and Lift Frame for easy attaching and detaching. Adjusts plow height in varying ground conditions for easy mount/dismount.
- 17. Plow Markers** – Attach to corner of moldboard providing line of site to the operator.

# General Maintenance



Clean all electrical connections and add dielectric grease once a month.

## Tightening the Trip Spring and Adjusting the Eye Bolt

To properly adjust the Trip Springs, tighten the top locknut 4 (four) complete rotations beyond the point that the coils begin to separate. Tighten the bottom locknut to hold eyebolt in position. It is important that each eye bolt is locked in this position to work properly when the moldboard experiences tripping action.

## Greasing the Pivot Pins and King Bolt

Use a grease gun to grease pivot pins and king bolt. This will keep your plow operating smoothly.

## Maintaining Cutting Edge and Mounting Bolts

Monitor the cutting edge of your plow for excessive wear and tear. Replace it as soon as it appears worn on either corner approximately 4". Replacing the cutting edge will prevent damage to the moldboard. Also, check and retighten all mounting bolts after the first plowing session of the season and at regular intervals throughout the season.

## Checking Oil Level

Use a standard drinking straw or clean stick to check your fluid level. Remove the filler cap and dip the straw into the fluid reservoir. Always check fluid level with the lift piston fully retracted. The fluid level should be 1-1/2" below the filler hole. If your fluid is low or appears excessively dirty, change your hydraulic fluid. Only use (#15134) Meyer Hydraulic M-1 Fluid. Change once per year.

Note: On Super-V3 and Super Blade make sure both wings are fully retracted.

## Monitoring the Condition of Your Hoses, Couplers, and Rams

Check all hoses for bubbles or cuts and couplers for rust or leaks. A failure in a hose or coupler will result in a loss in oil pressure and cause power angling failure. Check rams for rust and leaks, either of these problems can introduce water into your hydraulic system which may cause freeze-ups. If you find any of these problems, replace the damaged parts with Meyer Genuine Parts available from your local authorized retailer.

## Monitoring the Electrical System and Battery Terminal Connections

For maximum efficiency, the vehicle supporting the plow must be properly serviced. The system should consist of at least a 70-amp/hr battery and a 60-amp alternator. Be sure to regularly check the battery terminals to assure that they're clean and free of corrosion, adding (#15632) dielectric grease to all connections will help prevent corrosion from occurring. Also check the electrical connections to assure they're tight and corrosion free. Make sure that all wires are being held clear from moving or hot engine parts or from sharp sheet metal. For maximum efficiency, the battery, alternator, and regulator must be in top operating condition to assure maximum electrical output.

# General Maintenance

## Adjusting the Drop Speed

The rate at which the plow is lowered is adjustable. Turning the Lower Adjusting Screw in (clockwise) will decrease the speed at which the plow is lowered by gravity, and turning the screw out (counter-clockwise) will increase the drop speed.

## Adjusting the Runners

Inspect moldboard runners for wear and replace them as soon as they start to wear through. Adjust the runners to maintain cutting edge height of 1/2" above ground in snow plowing position. Set plow higher when plowing on gravel driveways.

## Storing the Plow and Hydraulic Unit

After you have disconnected the plow from your vehicle, extend the lift cylinder to end of the stroke and coat the lift rod with light grease. This fills the cylinder with hydraulic fluid and protects the interior and exterior from rust and corrosion. Also coat the exposed portions of the power angling cylinder rods with light grease. Be sure to plug in the weather plugs on Hydraulic Unit to keep them clean and to prevent contamination of the system. Coat all pivot pins and other wear points with chassis lubricant. Unplug all electrical connections at the power unit. Coat all connections with a dielectric compound to prevent corrosion and plug them into their corresponding plugs. Unplug the plow lights, use dielectric compound at light connections to prevent corrosion. Meyer M-2 Hydra-Flush should be used to flush contaminants from the system. It should also be used for off-season storage.

# Wingman General Maintenance\*

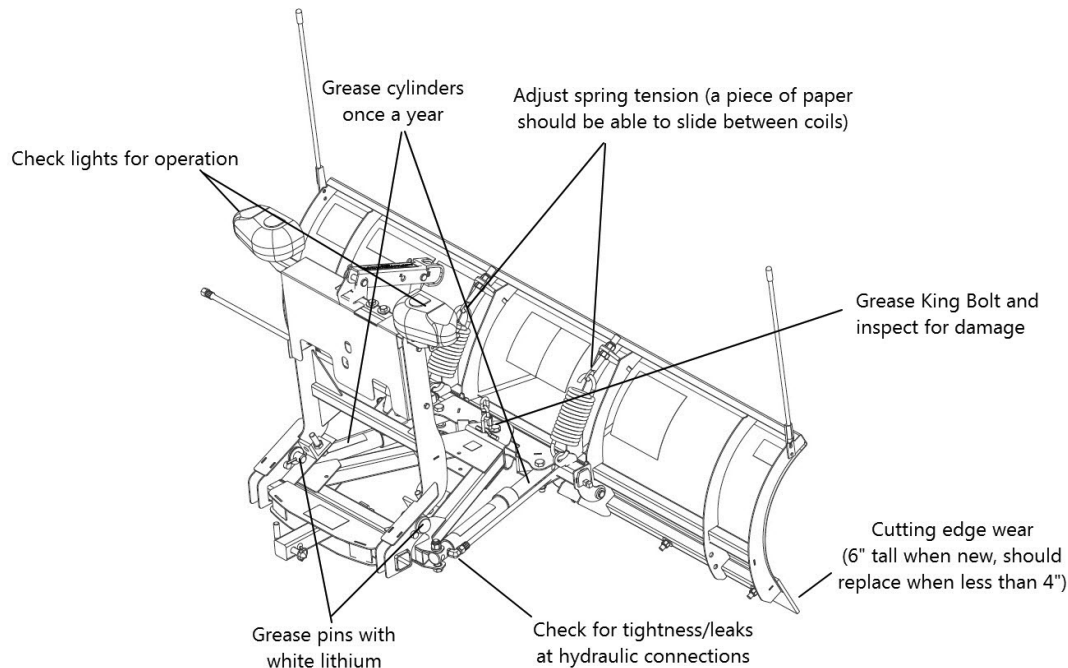

\*Image is a general representation of a Straight Blade model. Your specific model may appear differently, but the components are the same.



# Drive Pro General Maintenance\*

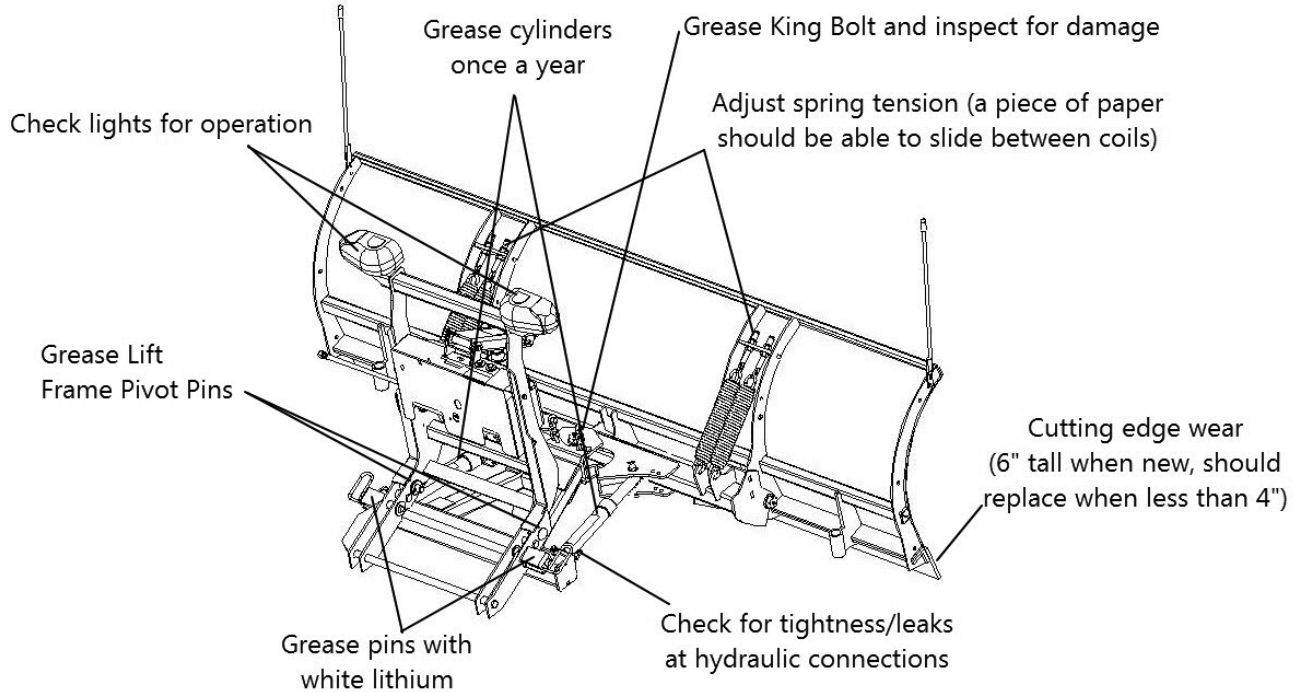

\*Image is a general representation of a Straight Blade model. Your specific model may appear differently, but the components are the same.

# Vehicle- Maintenance

Meyer Products LLC recommends this maintenance information for regular service. Sustained heavy operation may call for more frequent service. Snow plowing subjects a vehicle to exceptionally rugged use. As a result, it is very important to inspect and bring the snow plow and vehicle up to maximum operating conditions. Inspection should be made of both the vehicle and snowplow prior to the plowing season and after each use.

## Vehicle Pre-Season Maintenance

Scheduled vehicle maintenance should be performed as recommended by the manufacturer.

Don't forget that in addition to keeping equipment in order:

1. Keep windshield wipers, heaters and lights working.
2. Use emergency flasher lights for increased visibility and safety.
3. Equip vehicles with chains where necessary.
4. Provide operators with protective clothing and with rubber gloves for handling snow melting chemicals.

## Vehicle Electrical System Pre-Season Maintenance

For maximum efficiency, the vehicle supporting the snow plow must be properly serviced. The system should consist of at least a 70 amp./hr. battery and a 60 amp alternator. Be sure to check regularly:

1. Battery terminals to assure they're clean and free of corrosion.
2. Electrical connections, to assure they're tight and corrosion free.
3. Battery must be in top operating condition.
4. Alternator and regulator, to assure maximum electrical output.

**CAUTION:ALWAYS LOWER MOLDBOARD TO THE GROUND WHEN SNOW PLOW IS BEING SERVICED OR WHEN VEHICLE IS NOT IN USE.**

# Pre-Season Maintenance



Yellow and black paint is formulated to withstand harsh temperatures and the winter environment.

To have your plow ready for the first snow fall:

1. Check and maintain hydraulic fluid reservoir level to Full. Oil level should be checked with lift ram down or retracted position. On Super-V3 and Super Blade, wings should be retracted.
2. Check entire hydraulic system for leaks. A significant drop in hydraulic fluid level is evidence of a leak which must be corrected to prevent serious damage.
3. Before and after each season, Grease all pins and lubricate all pivot points with chassis lube.
4. ADJUSTING TRIP SPRING TENSION - Tighten top locknut 4 turns beyond the point when spring coils begin to separate. Tighten bottom locknut to hold eye bolt in position as shown
5. RUNNERS/SHOES
  - A. Inspect moldboard runners for wear and height adjustment.
  - B. Always replace runners as soon as they start to wear through.
  - C. Adjust the runners to maintain cutting edge height of 1/2" above ground in snow plowing position. (Can be set higher when used on gravel driveways).
6. CUTTING EDGE - REVERSIBLE ON TRIP EDGE PLOWS - Replace the cutting edge as soon as it appears worn. This will prevent permanent damage to the plow.
7. MOUNTING BOLTS - Retighten all mounting bolts after first snow plowing session and at regular intervals through the season.
8. SNO-FLO® POWDER COATING, both black and yellow, should be checked at the beginning and end of each season for any signs of rust. If any exists, use Meyer special Sno-Flo® powder coat touch-up available in spray cans.
9. Check lighting system to make sure all bulbs are functioning: headlights Hi/Low - turn signals.

#### NOTE: PROTECTION AGAINST RUST AND CORROSION

When the power unit is not used for extended periods, protect the chromed lift rod by fully extending and coating it with chassis lubricant. Coat the exposed portions of the power angling cylinder rods with chassis lubricant to protect against corrosion.

# Post-Season Maintenance

1. Drain the fluid by removing the drain plug located on the bottom of unit. To drain the fluid from the power angling cylinders, disconnect the fittings and completely retract the cylinder rods and purge cylinders and hoses of all hydraulic fluid. The complete system should then be flushed out with Meyer M-2 Flushing Fluid before adding new Meyer Hydraulic Fluid.
2. Meyer M-1 Hydraulic Fluid (#15134) is specially formulated with an anti-ice additive for almost constant viscosity in subzero temperatures. Because it is free-flowing in extreme cold, the unit's performance and efficiency are not affected by winter weather. It is effective for a maximum of one year. Always carry an extra quart of Meyer M-1 Hydraulic Fluid. Use of any inferior fluids will void the Meyer warranty.
3. Refill power unit with Meyer M-1 Hydraulic Fluid by fully retracting lift piston and filling reservoir to top. Note: Do not over fill unit, over filling unit will cause oil to squirt out of the reservoir pressure relief valve. Power angling rams should be collapsed on all plow models and wings retracted on Super-V3 and Super Blade. Install Hydraulic unit and Moldboard assembly on vehicle. Remove reservoir pressure relief valve (Filler plug). To bleed air from the system power angle wings side to side while maintaining a constant check on the reservoir fluid level. Note: It may be necessary to bleed air from the Power angling cylinders by loosening the hydraulic fittings. Angle plow left and right until you have a steady stream of oil coming out of fitting. Raise and lower the plow several times. With lift ram fully retracted (down) check fluid level and replace filler plug.



Meyer M1 Hydraulic oil and M2 Flush is scientifically formulated to withstand extreme winter temps up to -40°F.

# Snow Plow Storage

1. When snow plow is disconnected, disconnect lift chains from lift arm and extend lift cylinder to end of stroke and coat chrome rod with light grease. This fills the cylinder with hydraulic fluid and protects the interior and exterior from rust and corrosion.
2. Whenever Moldboard is disconnected, coat the exposed portions of the power angling cylinder chrome rods with light grease to protect them from corrosion.
3. Coat pivot pin and other wear points with chassis lubricant. Be sure to grease all grease holes.
4. Unplug electrical connection at power unit. Coat connection with a dielectric compound to prevent corrosion and plug into their corresponding weather plug.
5. Reference post season maintenance on page 21 prior to final storage.



# Base Line Component Identification

Item	Part No.	Qty.	Description
1	31101J	1	• 240 Hopper
1	36101J	1	• 400 Hopper
2	31102J	1	• 240 & 400 Hopper Cover
3	34413	1	• Spreader Frame
4	34415	1	• Deflector Bracket
5	34401	1	• Deflector
6	34416	2	• Tube Plug
7	36402A	1	• Motor 12V D.C.
8	34011	1	• Auger Center Post
9	34302	1	• Brush Auger Rock Salt
10	36152	1	• Spinner Hub Weldment
11	36158	2	• Spinner Mounting Plate
12	36415	1	• Spinner (Poly)
13	34414	1	• 240/400 Hitch Assembly
14	20007	3	• Bolt H 1/4 - 20 x 1-1/2" Gr. 2
15	20010	4	• Bolt H 1/4 - 20 x 2-1/4" Gr. 2
16	20027	8	• Bolt H 5/16 - 18 x 1" Gr. 2
17	21834	1	• Set Screw 3/8-24 x 3/8

Item	Part No.	Qty.	Description
18	22728	1	• Set Screw 3/4-10 SS
19	20303	7	• Locknut 1/4 Esna
20	20313	8	• Locknut 5/16 Esna
21	20351	8	• Flatwasher 1/4
22	20352	16	• Flatwasher 5/16
23	22996	1	• Bolt H 1/4-20 x 2" SS
24	22997	1	• Locknut 1/4-20 SS
	08259	1	• 240/400 Hitch Hardware Bag
25	11101	1	•• Hinge Pin
26	20069	4	•• Bolt H 3/8-16 x 3"
27	20314	4	•• Locknut 3/8
28	20353	8	•• Flatwasher 3/8
29	22083	1	•• Linch pin
	31104	1	• 240/400 Wiring Kit
30	34405	1	•• Controller
31	36240	1	•• Socket Assy. w/Mtg. Plate
32	36241	1	•• Plug Assembly
33	36242	1	•• Wire, Red 264"
34	36247	1	•• Wire, Red 96"

54 Parts indented are included in the assembly under which they are indented.

# Base Line Component Identification

## Base Line 240/400

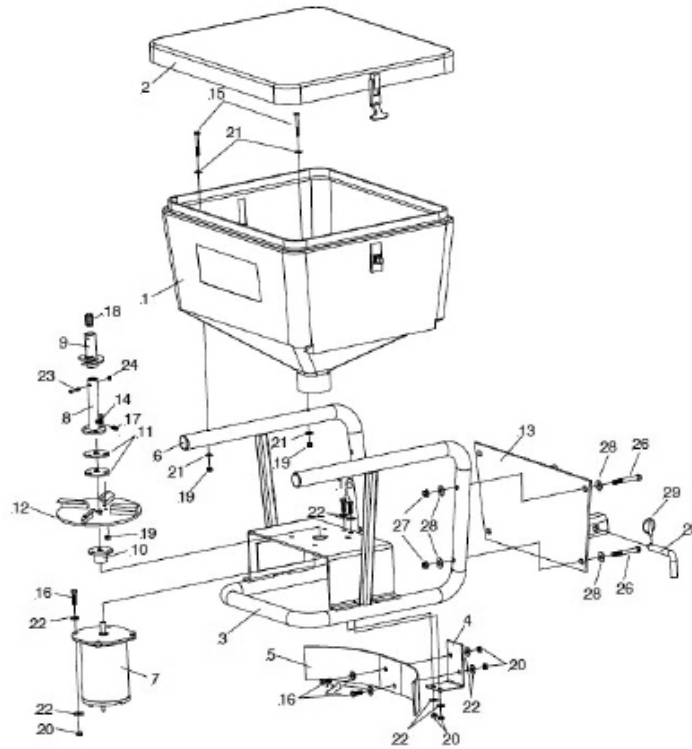

# Base Line Receiver Mount

**CAUTION:** Always disconnect battery before beginning installation.

**CAUTION:** The spreader is a large heavy item that should be installed with an assistant. As with any new equipment installation read and understand all instructions prior to starting the job, and do not hurry through it. A correct installation now can save time and money later.

Check contents against the parts list to determine all are correct and included, and also to familiarize yourself with them.

Locknuts are furnished. DO NOT tighten bolts and nuts until installation is complete (unless otherwise specified), then be sure to tighten all attaching parts per specified torque chart.

When ordering parts, furnish Part No., Name and Description.

1. Assemble Hitch Assembly (13) to Spreader Frame (3) using 3/8-16 x 3" Bolt (26), 3/8 Flatwasher (28) and 3/8 Locknut (27)
2. Slide Spreader Assembly into receiver hitch on vehicle and insert Hinge Pin (25) through corresponding hole on receiver and Hitch Assembly (13). Secure Hinge Pin (25) with Linch Pin (29).
3. Tighten all bolts to their required torque using the chart below.





# Base Line Installation

1. Choose a location for the Controller (30) that is convenient for the driver. Make certain Controller (30) is grounded by attaching ground wire to a good vehicle ground.
2. Attach the eyelet end of the 96" red wire (34) to the positive terminal of the battery and route the plug end to the location of the speed control. DO NOT attach to Controller (30) at this time.
3. Take the 264" red wire (33) and route the large rubber plug end to the rear of the truck, securely tying to vehicle frame. Be certain wire is clear of any sharp or moving objects or the vehicle's exhaust system.
4. CAUTION: Some vehicles are designed to operate with exhaust temperatures as high as 1800°F. This can easily damage any wires which are routed too closely or allowed to come in contact with any portion of the exhaust system. Be certain all wires are securely installed away from the exhaust system.
5. Be certain the motor leads will not be strained when the plug is attached. Plug the 264" red wire (33) into the socket. Secure black wire from socket (31) to a good grounding point on vehicle frame. Clean all rust or undercoating from this area.
6. Attach red wire from motor plug (32) to positive (+) terminal of motor. Tape this connection! Attach black wire to negative (-) terminal of motor. Push plug (32) into the socket (31).
7. Perform the motor run test as described in paragraphs 3 and 4 of the "Caution" above. If the motor operates 264" red wire (33) and 96" red wire (34) can be attached to their respective terminals on the Controller (30).
8. Meyer Products assumes no responsibility for installations not made in accordance with these instructions.

# Base Line Controller

## Installation

The BL Controller is an electronic module powered off the switched ignition circuit +12Vdc and supplying the heavy motor current from the +12Vdc battery circuit. The controller will only function with the ignition key in the ON state. The controller is connected to the spinner motor and vibration motors via a custom wire harness that is designed to handle the high motor currents. The controller can be mounted under the vehicle dash using mounting hardware that is provided in the kit. The controller is weatherproof and can be mounted in areas where it will get wet. The controller includes 5 wires as follows:

1. Ignition wire Blue (power to the controller through switched ignition).
2. Power wire Red (power to the controller directly from 12V battery).
3. Output wire White (connects to the spreader motor positive post).
4. Output wire Green (connects to the option 1 vibrator motor).
5. Ground wire Black (provides ground for the controller).

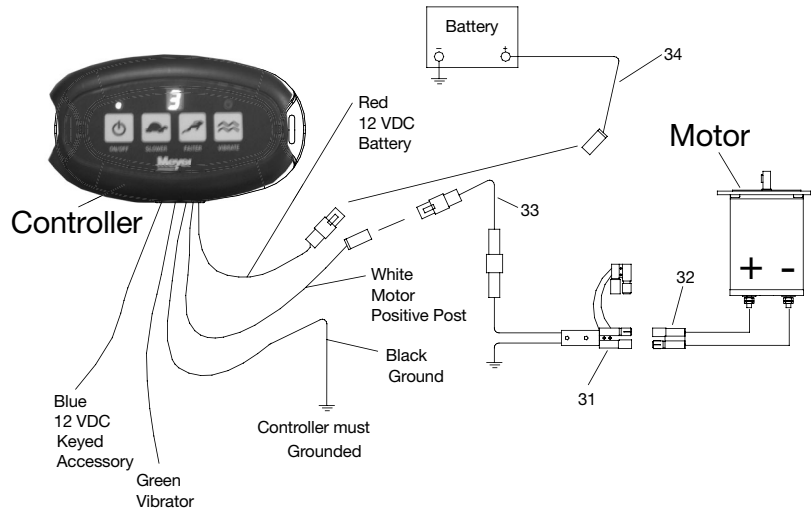

# Base Line Controller

The controller will provide the spreader motor with multiple speed options per following:

ON/OFF	Depress the button once to enable the spreader motor operation. Spreader motor will automatically be activated with 5 full power Blasts and then stop. The GREEN LED located above this switch will illuminate.
ON/OFF	Depress the button a second time and the spreader motor operation will stop. The GREEN LED located above this switch will stop illuminating.
FASTER	Once spreader is activated, by depressing the FASTER button momentarily for the first time, the motor will start rotating at the lowest speed. If the button is depressed again, motor will gain speed. Faster button can be depressed momentarily or held depressed to achieve maximum speed. There are ten programmed speed settings that increase the speed in increments of 10%. The GREEN LED located above the I/O button will flash in unison with the speed setting. The fastest speed causes the GREEN LED to flash at a rate of 10 flashes every second.
SLOWER	By depressing the SLOWER button, the motor speed will decrease. There are ten programmed speed settings that decrease the speed in increments of 10%. SLOWER button can be depressed momentarily or held depressed to slow down the motor until it comes to a halt. The LED located in the center will provide a number for the speed setting. 1 is slowest and 10 is fastest.
VIBRATE (On/Off)	Depress the button once to enable the vibrate motor operation. The GREEN LED located above this switch will illuminate at full intensity.
VIBRATE (On/Off)	Depress the button a second time and the vibrate motor operation will stop. The GREEN LED located above this switch will stop illuminating.

Controller will only be activated while ignition switch is at ON position. If the unit is wired into a keyed power source. There will be one inline fuse located at the incoming power wire harness. This will be a 20A automotive ATO fuse. This 20A fuse protects the spreader motor and/or vibrate motor from over current conditions. In the event that the fuse has opened circuited, replacement of the fuse will be required in order to restore the operation. Fuse replacement is facilitated with a pair of needle nosed pliers. The controller also has overload protection built into the circuit board. If an overload occurs the green LED above the I/O button will turn red and will begin to flash. To reset, turn off controller and clear obstruction from spreader then turn controller back on.

# Blaster Component Identification

Item	Part #	Qty.	Description
	77000	1	Blaster Assembly
1	32100J	1	• Hopper Assembly
2	22729	2	•• Bolt 1/4-20 x 5/8" SS
3	34407	2	•• Latch Hook
4	34200	1	• Lid Assembly
5	22725	4	•• Bolt 1/4-20 x 3/4" SS
6	34408	2	•• Rubber Latch
7	32200	1	• Frame Assembly
8	35001	1	• Hitch Weldment
9	34101	1	• Motor Mount
10	34102	1	• Motor
11	22730	4	• Bolt 3/8-16 x 1-1/4" SS
12	22734	4	• Flatwasher 3/8" SS
13	22735	4	• Locknut 3/8-16 SS
14	36415	1	• Spinner
15	34011	1	• Auger Center Post
16	34306	1	• Auger
17	34604	1	• Auger Extension
18	22996	1	• Bolt 1/4-20 x 2" SS
19	22725	3	• Bolt 1/4-20 x 3/4" SS
20	22727	3	• Locknut 1/4-20 SS
21	22997	1	• Locknut 1/4-20 SS
22	22724	3	• Flatwasher 1/4" SS

Item	Part #	Qty.	Description
23	22726	1	• Set Screw 5/16" SS
24	22759	1	• Set Screw 3/4-10 x 2 SS
25	34601	1	• Baffle Plate
26	34401	1	• Deflector
27	34402	1	• Hopper Collar
28	34400	1	• Motor Guard
29	22736	4	• Bolt 1/2-13 x 3" SS
30	22732	4	• Locknut 1/2-13 SS
31	22733	8	• Flatwasher 1/2" SS
32	22737	18	• Bolt 3/8-16 x 1" SS
33	22735	18	• Locknut 3/8-16 SS
34	22734	35	• Flatwasher 3/8" SS
35	-	2	• Bolt 1/4-20 x 3/4" SS
35	22725	8	• Bolt 1/4-20 x 3/4" SS
36	-	2	• Locknut 1/4-20 SS
36	22727	6	• Locknut 1/4-20 SS
37	-	2	• Flatwasher 1/4" SS
37	22724	6	• Flatwasher 1/4" SS
	32218	1	• Carton Accessory Parts
38	34106	1	•• Wire Harness
39	22800	1	•• Controller

Item	Part #	Qty.	Description
40	22731	1	•• Hinge Pin w/ Clip
	32216	2	•• Tie Down Hook
	32217	2	•• Ratchet Tie Down
41	34602	1	• Vibrator

Parts indented are included in the assembly under which they are indented.

# Blaster Component Identification

## Blaster 350S

**Note:** 350S Auger Extension (17) must be removed when using salt only. If it is not removed this may cause the motor to stall.

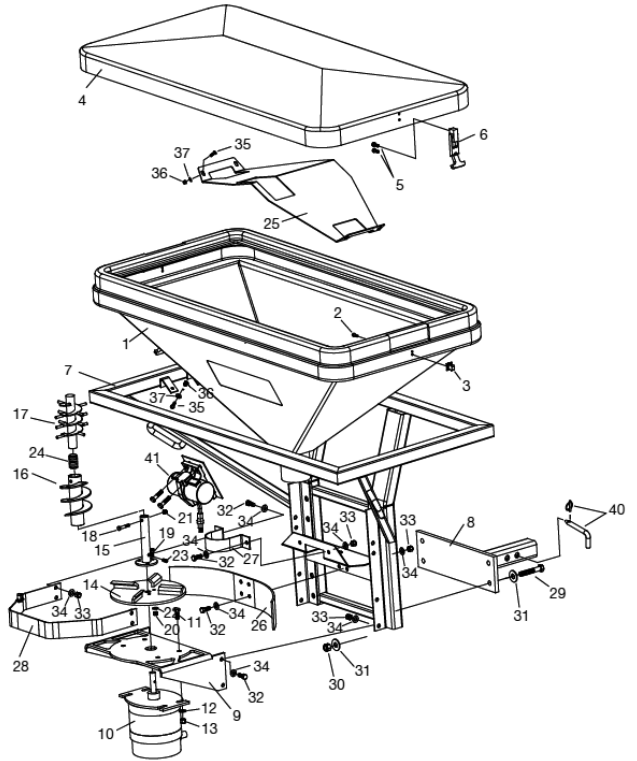
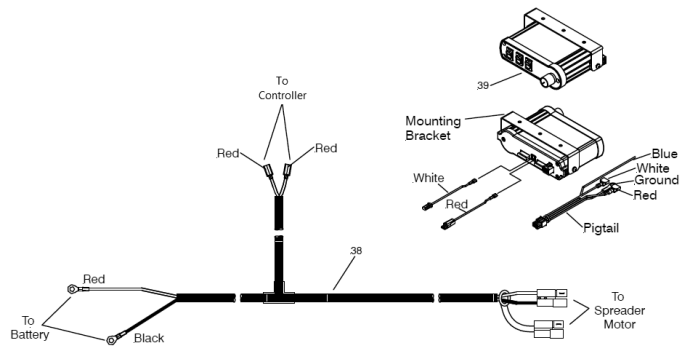

# Blaster Receiver Mount

The Blaster 350/350S/750R/750RS is a dedicated 2" receiver hitch mount salt spreader. Prior to installation, be certain that the vehicle receiver is in good working order, is rated for at least a 500 lb. (227kg) tongue load, and is fastened to the vehicle securely.

**CAUTION** - The spreader is a large heavy item that should be installed with an assistant. As with any new equipment installation read and understand all instructions prior to starting the job, and do not hurry through it. A correct installation now can save time and money later.

1. Using an assistant remove the spreader unit and all loose components from the packaging and set cover aside until installation is complete. Retain original packaging for storage purposes. Locate the large hitch pin and cotter clip (40) from the hardware package. Set these items aside, as they will be used later during the installation.
2. Inspect the vehicle's receiver tube and check for rust, dirt, or foreign debris that may have collected in it. If there are any blockages clean with compressed air and a wire brush.
3. Apply good quality grease to the inside of the receiver tube, this will prevent rusting and make the spreader easier to remove at the end of the season.
4. The framework will have four 1/2-13 x 3" SS Bolts (29) already installed in the mounting holes for the stinger. Remove the 1/2-13 SS Locknuts (30) and 1/2" SS Flatwashers (31) and apply a light oil to the threads, this will make assembly easier; yet will not affect the locking properties of the safety nuts. Place the hitch assembly over the bolts, replace the nuts and washers and fully tighten.
5. Lift the spreader unit upright (hopper opening facing up) with mounting tube pointed toward the truck.
6. Slowly slide spreader mounting tube into the vehicles receiver until the through holes in receiver match through holes in spreader. (See note below)
7. Insert the large hitch pin (40) through the receiver tube and spreader mounting tube. Secure with the cotter clip (40). **WARNING** – The cotter clip (40) must be in place for safe operation.
8. Place the cover over the hopper and secure clamps on left and right sides.
9. Use the Ratchet Tie Down Strap and Tie Down Hooks to tie spreader to vehicle frame to eliminate any rocking of the spreader.

## NOTE:

- The spreader mounting tube has two pre-punched hole sets to provide some adjustment when installing the unit.
- Always use the hole set that places the unit closest to the vehicle but without touching it.
- 

**WARNING** – Never attempt to drill new holes in the spreader mounting tube, contact your local trailer hitch supplier about relocating or replacing you current hitch, if mounting problems occur.

# Blaster Receiver Mount

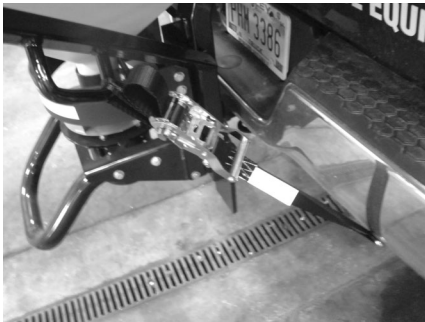
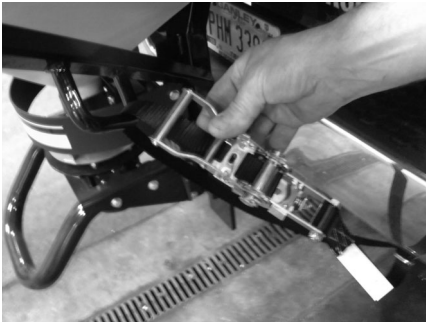

# Blaster Installation

1. Locate the wire harness (38) and begin to route it from the rear of the vehicle to the front. The molded rubber plug indicates the rear of the harness, closest to the spreader. Use frame holes and frame supports as lashing points. Do not attach to fuel or brake lines. Avoid wire-runs along exhaust system or hot engine parts. Melting damage to the harness can occur in the proximity of extreme heat.
2. Mount the rubber plug under the rear bumper. Position this plug toward the center of the vehicle.
3. Place the Harness (38) portion that connects to the battery along the firewall and fender well, but do not connect yet.
4. Drill a 1" diameter hole through the firewall. This hole will be used to route the controller portion of the harness into the vehicle. Before drilling always check to see what is on the other side.
5. Push the controller portion of harness through the hole in the firewall that was previously drilled.  
**NOTE:** The controller end will have 2 plugs on it, but only 1 plug can pass through the firewall at a time.
6. Move to engine compartment. Connect power leads to battery: RED WIRE (+) positive, BLACK WIRE (-) negative. Coat the connections with dielectric grease to prevent corrosion and build up. Check harness marked 'battery' for voltage by temporarily removing the red tape affixed to it.
7. Connect the blue wire from pigtail to brake light. Connect white wire from pigtail to optional vibrator harness if equipped. Connect red wire on pigtail to a 12 volt keyed accessory. Connect black ground wire to ground. Connect white jumper wire to the back of the controller marked motor white wire. Connect red jumper wire to the back of the controller marked battery red wire. The two red wires from the main connector can now be connected to the two jumper wires. **NOTE:** Wires will only connect one way. ANY ATTEMPT TO JOIN THE CONNECTORS IMPROPERLY, FOR EXAMPLE MALE TO MALE, WILL NOT ALLOW THE CONTROLLER TO FUNCTION.
8. Select a suitable location to mount the controller. After mounting verify that the power switch is in the off position.
9. Coil excess wire and use wire ties to secure it to a safe location.
10. Mate the plug coming from the spreader unit to the plug previously installed under the rear bumper.
11. Make sure that feed screw/spinner area of the spreader is clear of obstructions. Turn power on at the controller and verify that the spreader is operating in all modes. Looking down on the impeller from the rear of the vehicle, determine that the impeller is turning counter-clockwise. Unit may now be operated.



# Blaster Controller

The controller is equipped with a power on switch, blast switch, vibrate switch and rotary speed control. Once the ignition key is turned to the ON position, the controller face plate will illuminate white indicating that the controller is ready for operation. During operation, face plate color will vary depending on the mode of operation and status of the controller. If the vehicle ignition is shut off while the controller power switch is in the ON or AUTO position the controller will turn off. Once the vehicle ignition is turned back on the controller will not illuminate or turn on unless the controller power switch is first turned off.

To start the spreader, be sure that the vehicle engine is running to prevent battery from wearing down, flip the power switch to position I for normal mode or position II for auto mode. Once power switch is ON, the spreader will power up with 5 full blast for approximately one second then drop to wherever the dial has the speed set at. Adjust the speed of the spreader by rotating the dial clockwise for faster and counterclockwise for slower. The face plate will illuminate greener as the speed increases and will change completely to green at maximum speed.

If auto mode is selected, the face plate color will change to amber, the spreader will power up with 5 full blast for approximately one second then drop to wherever the dial has the speed set at. In this mode, if the brake is applied for more than 5 seconds, the spreader will stop and once the brake pedal is released, spreader will resume its operation.

The blast switch provides momentary full power override. During operation if blast switch is depressed, spreader will go on to full speed and the face plate color will change to blue.

If vibrator switch is flipped to the ON position I, vibrator motor will be activated as long as the switch is maintained at position I and the face plate will illuminate purple. If vibrator auto mode is selected at position II, vibrator motor will activate for 10 seconds every 60 seconds and will cycle the motor ON and OFF as long as the switch is maintained at AUTO position II. Face plate will change color to purple whenever the vibrator motor is activated.

In case there is an overload condition, the face plate will change to red color and the spreader will stop. The Power ON / OFF or AUTO switch will need to be turned OFF to reset the controller.

**SPREADING HINTS:** Never exceed 10 M.P.H. (16 kmh) when spreading. For a wider pass, increase spinner speed. For a heavier pass, drive more slowly. Never operate spreader around people and calculate spread pattern around vegetation.



# Spreader Maintenance

Maintenance requirements for the Spreader during the winter season are relatively simple. Periodically inspect for loose bolts and nuts. Inspect for improper ground, broken wires, frayed or cracked wire insulation. Replace as necessary.

**WARNING:** Disconnect power to spreader before servicing.

**CAUTION:** Do not attempt to service control unit. It is a solid-state electronic device and has no user serviceable parts; any attempt to do so will void warranty.

**CAUTION:** The electric motor is sealed and should not be taken apart for any reason. Disassembly of the motor will void warranty.

**CAUTION:** When replacing parts use only Meyer Products approved parts or risk voiding warranty.

**CAUTION:** When filling Hopper, make certain there are no large objects contained in the material which could cause the Auger Spinner to bind and stop operation of the Spreader Motor. It is recommended to check for free rotation of the Auger Spinner before operating the Spreader due to possible buildup of material between the Auger and neck of the Hopper.

- Use dielectric grease on all electrical connections, before and after each season and whenever the plugs are disconnected. This will ensure long life for the contacts and prevent corrosion.
- Wash unit after each use to prevent material build-up and corrosion.
- Periodically inspect the motor seal located around the shaft and look for cracks or splits. If seal is damaged or missing contact the manufacturer for a replacement.
- At the end of the season thoroughly clean all parts and paint or oil all bare metal surfaces (except for hopper and spinner which are stainless steel and do not require painting). Using a paste wax on the inside of the hopper will help material flow smoothly. OIL SHAFT AT MOTOR BASE TO PREVENT RUST DURING NON-USE.
- Do not attempt to clear Auger or Spinner or to perform any other maintenance or repair work on this Spreader unless the ignition switch is in the "OFF" position and the Motor Plug (28) is disconnected from the Socket Assembly (27).
- Salt must be loose and free from lumps and must be kept dry.
- Empty Hopper after each use and hose the Spreader off.
- When the Spreader is no longer being used, remove it from the vehicle. Remove any rust or corrosion from the metal parts, then prime the paint. Store Spreader in a suitable location and attach weather plug (32) to socket (28) to protect from corrosion.

# Spreader Troubleshooting

If your spreader is not operating properly, take it to your local Meyer Products Distributor for maintenance or service. However, that is not always possible, so below on this page you will find a troubleshooting guide, which can assist you in determining the problem.

**WARNING** – Before performing any service read and understand all safety guidelines stated in this manual.









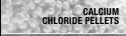
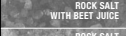

## BEFORE CALLING YOUR DEALER:

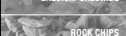
Be sure all electrical connections are clean and tight.

Be sure vehicle power supply is working properly (battery charged)

Check the hopper for a jammed feed screw.

PROBLEM	POSSIBLE CAUSE	SOLUTION
Motor does not run.	<ul style="list-style-type: none"> <li>Loose electrical connection.</li> </ul>	<ul style="list-style-type: none"> <li>Check all electrical connections.</li> </ul>
Shut Down.	<ul style="list-style-type: none"> <li>Auger or spinner jammed</li> <li>Jammed auger.</li> <li>Poor electrical connections.</li> <li>Electrical short.</li> </ul>	<ul style="list-style-type: none"> <li>Carefully remove jammed material.</li> <li>Carefully remove jammed material.</li> <li>Clean or replace connectors.</li> <li>Look for bare or loose wires.</li> </ul>
Material will not feed.	<ul style="list-style-type: none"> <li>No material in the hopper.</li> <li>Material is wet.</li> <li>Frozen or coarse material.</li> <li>Auger loose on motor shaft.</li> <li>Controller bad.</li> </ul>	<ul style="list-style-type: none"> <li>Fill hopper.</li> <li>Replace with dry material.</li> <li>Replace material.</li> <li>Tighten setscrew on side if auger. There is a flat machined into the motor shaft, this set screw must tighten onto that flat.</li> <li>Replace controller.</li> </ul>

Material	Base Line	Blaster
 CALCIUM CHLORIDE FLAKES		•
 CALCIUM CHLORIDE PELLETS	•	•
 ROCK SALT WITH BEET JUICE		
 ROCK SALT (SMALL GRANULATION)	•	•
 ROCK SALT	•	•
 CALCIUM CHLORIDE	•	•
 ROCK CHIPS		
 BAGGED ICE MELT	•	•
 LAVA ROCK		
 EARLY GMA		
 50/50 SAND/SALT MIX		•
 SAND		•
 PEA GRAVEL		
 SHOULDER GRAVEL		

# Spreader Calibration

## LANE MILE CALIBRATION (US)

DISCHARGE RATE (pounds discharged per mile)

Control Setting	A	B	C	TRAVEL SPEED AND COMPUTATION MULTIPLIER								
	Shaft RPM (Loaded)	Discharge per Revolution (lbs.)	Discharge per Minute (lb) (A x B)	5 mph (C x 12.00)	10 mph (C x 6.00)	15 mph (C x 4.00)	20 mph (C x 3.00)	25 mph (C x 2.40)	30 mph (C x 2.00)	35 mph (C x 1.71)	40 mph (Cx 1.50)	45 mph (C x 1.33)
1												
2												
3												
4												
5												
6												
7												
8												
9												
10												

The actual application rate (lbs. per lane mile) on the highway is the discharge rate divided by the number of lanes being treated.

### Spreader Calibration Procedure

Calibration is simply calculating the pounds per mile discharged for each control setting at various travel speeds by first counting the number of auger or conveyor shaft revolutions per minute, measuring the weight of salt discharged in one revolution, then multiply the two to obtain discharge per minute, and finally multiplying the discharge per minute by the time it takes to travel 1 mile.

### Equipment needed:

1. Scale to weigh salt
2. Salt collection device
3. Marking device
4. Watch with second hand

### Calibration steps:

1. Remove spinner assembly.
2. Put partial load of salt in spreader.
3. Mark shaft end of auger.
4. Count number of shaft revolutions per minute at each spreader control setting, record.
5. Collect salt discharged for one revolution, weigh it and deduct the weight of the container. (For greater accuracy, collect salt for several revolutions and divide by that number of revolutions to get the weight for one revolution.)

# Spreader Calibration

## PARKING LOT CALIBRATION (US)

DISCHARGE RATE (pounds discharged per square foot)

	A	B	C	D	E	F	G	H	I	(lbs. discharged per sq. ft.)			
Control Setting	Shaft RPM (Loaded)	Spread Pattern width (ft.)	Spread Pattern sq. ft. (.5 x B) x (.5 x B) x (3.14)/2	Discharge per Auger Revolution (lbs.)	Discharge per Minute (b) (A x C)	5 mph (D x 12.00)	10 mph (D x 6.00)	15 mph (D x 4.00)	20 mph (D x 3.00)	5 mph F/(C x 5280)	10 mph G/(C x 5280)	15 mph H/(C x 5280)	20 mph I/(C x 5280)
1													
2													
3													
4													
5													
6													
7													
8													
9													
10													

The actual application rate (lbs. per sq. ft.) on the parking lot.

### Spreader Calibration Procedure

Calibration is simply calculating the pounds per mile discharged for each control setting at various travel speeds by first counting the number of auger or conveyor shaft revolutions per minute, measuring the weight of salt discharged in one revolution, then multiply the two to obtain discharge per minute, and finally multiplying the discharge per minute by the time it takes to travel 1 mile.

### Equipment needed:

1. Scale to weigh salt
2. Salt collection device
3. Marking device
4. Watch with second hand

### Calibration steps:

1. Remove spinner assembly.
2. Put partial load of salt in spreader.
3. Mark shaft end of auger.
4. Count number of shaft revolutions per minute at each spreader control setting, record.
5. Collect salt discharged for one revolution, weigh it and deduct the weight of the container. (For greater accuracy, collect salt for several revolutions and divide by that number of revolutions to get the weight for one revolution.)

# Meyer® Base Line Spreader Warranty

Meyer Products, LLC, warrants to the original purchaser of Meyer® brand products that they will be free from defects in materials or workmanship, with the exceptions stated below. No person is authorized to change this warranty or to create any additional warranty on Meyer products.

This warranty runs for a period of one year from the date of purchase on any purchase of a complete BL Spreader Package. If the package is registered on-line at [www.meyerproducts.com](http://www.meyerproducts.com) within sixty (60) days of purchase, your warranty for the Package will be extended for a period of one year. All foregoing warranties apply only to an original purchaser of the product if the product is installed by an authorized Distributor/Sub-Distributor and terminate if the product is sold or otherwise transferred. Some states do not allow limitations on how long an implied warranty lasts, so the above limitation may not apply to you.

- Problems caused by failure to follow the product instructions, failure to maintain the product as described in the Operator's Manual;
- Problems caused by contamination or damage resulting from rust, corrosion, freezing or overheating;
- Paint, or expendable spreader parts such as Auger or Spinner;
- Damage to any vehicle to which the products are mounted;
- Damage caused by usage that is not in accordance with product instructions (use of the spreader for any purpose other than spreading salt/sand is considered misuse and abuse);
- Any spreader, or any part, component, or assembly thereof, which has been modified or altered;
- Problems caused by using accessories, parts, or components not supplied by Meyer Products;
- Cost of tax, freight, transportation or storage charges, environmental charges, solvents, sealants, lubricants or any other normal shop supplies;
- Problems caused by collision, fire, theft, vandalism, riot, explosion, lightning, earthquake, windstorm, hail, water, flood, or any other Acts of God;
- Liability for damage to property, or injury to, or death of any person arising out of the operation, maintenance or use of the covered product;
- Products with missing or altered serial numbers;

The original purchaser's sole and exclusive remedy against Meyer Products and its Distributors and Sub-Distributors, and Meyer Products' sole obligation for any and all claims, whether for breach of contract, warranty, tort (including negligence) or otherwise shall be limited to providing, through its authorized Distributor/Sub-Distributor network, all labor and/or parts necessary to correct such defects free of charge. Any cost incurred in returning the product to an authorized Meyer Distributor/Sub-Distributor is the responsibility of the original purchaser. ALL EXPRESS AND IMPLIED WARRANTIES FOR THE PRODUCT, INCLUDING, WITHOUT LIMITATION, ANY IMPLIED WARRANTIES OF MERCHANTABILITY AND FITNESS FOR A PARTICULAR PURPOSE, ARE LIMITED IN TIME TO THE TERM OF THE LIMITED WARRANTY PERIOD. NO WARRANTIES, WHETHER EXPRESS OR IMPLIED, WILL APPLY AFTER THE LIMITED WARRANTY PERIOD HAS EXPIRED. Meyer Products disclaims liability beyond the remedies provided for in this limited warranty, and disclaims all liability for incidental, consequential, and special damages, including, without limitation, any liability for third-party claims against you for damages, for products not being available for use, or for lost profits. Meyer® Products' liability will be no more than the amount you paid for the product that is the subject of a claim; this is the maximum amount for which we are responsible. Some states do not allow the exclusion or limitation of incidental or consequential damages, so the above limitation or exclusion may not apply to you. A complete BL Spreader Package consists of the Spreader Assembly, operating controller, Spreader Frame and all related items. Structural elements consist of the Spreader Frame, Mounting and Poly Hopper.

# Meyer® Base Line Spreader Warranty

Meyer Products will repair any product that proves to be defective in materials or workmanship. In the event repair is not possible or practical (as determined by Meyer Products in its sole discretion), Meyer Products will either replace the product with a new product of similar model and price, or refund the full purchase price, as determined by Meyer Products.

Customer must keep the complete BL Spreader Package serviced/maintained as recommended by Meyer Products. A written record of service must be maintained, along with receipts for maintenance materials purchased. A copy of the maintenance record and pertinent receipts may be requested in the event of a claim.

In order to obtain service under this warranty, the original purchaser must:

- Use all reasonable means to protect the complete BL Spreader package from further damage;
- Return the claimed defective part to the Meyer Distributor/Sub-Distributor from whom the product was purchased or to any authorized Meyer Distributor/Sub-Distributor, transportation and freight charges prepaid. Only Meyer Distributors/Sub-Distributors are authorized to perform the obligations under this warranty. For the address and telephone number of the Meyer Distributor/Sub-Distributor nearest you, check the telephone directory, go to [www.meyerproducts.com](http://www.meyerproducts.com), write us at the address below, or call (216) 486-1313 for assistance;
- Provide maintenance record and receipts for required maintenance, if requested;
- Allow inspection of damaged parts and/or complete BL Spreader package if deemed necessary by Meyer Products;
- It is the responsibility of the original purchaser to establish the warranty period by verifying the original delivery date; A bill of sale/sales receipt, cancelled check or some other appropriate payment record may be kept for that purpose;

This warranty gives you specific legal rights, and you may also have other rights which vary from state to state.

How to register your Meyer Base Line Spreader to receive the warranty go to [www.meyerproducts.com](http://www.meyerproducts.com) and click on the link to register your plow. Fill out the information on the form as required.

# Meyer® Blaster Spreader Warranty

Meyer Products, LLC, warrants to the original purchaser of Meyer® brand products that they will be free from defects in materials or workmanship, with the exceptions stated below. No person is authorized to change this warranty or to create any additional warranty on Meyer® products.

This warranty runs for a period of two years from the date of purchase on any purchase of a complete Blaster Spreader Package. If the Package is registered on-line at [www.meyerproducts.com](http://www.meyerproducts.com) within sixty (60) days of purchase, your warranty for the Package will be extended for a period of three years. All foregoing warranties apply only to an original purchaser of the product if the product is installed by an authorized Distributor/Sub-Distributor and terminate if the product is sold or otherwise transferred. Some states do not allow limitations on how long an implied warranty lasts, so the above limitation may not apply to you.

- Problems caused by failure to follow the product instructions, failure to maintain the product as described in the Operator's Manual;
- Problems caused by contamination or damage resulting from rust, corrosion, freezing or overheating;
- Paint, or expendable spreader parts such as Auger or Spinner
- Damage to any vehicle to which the products are mounted;
- Damage caused by usage that is not in accordance with product instructions (use of the spreader for any purpose other than spreading salt/sand is considered misuse and abuse);
- Any spreader, or any part, component, or assembly thereof, which has been modified or altered;
- Problems caused by using accessories, parts, or components not supplied by Meyer Products;
- Cost of tax, freight, transportation or storage charges, environmental charges, solvents, sealants, lubricants or any other normal shop supplies.
- Problems caused by collision, fire, theft, vandalism, riot, explosion, lightning, earthquake, windstorm, hail, water, flood, or any other Acts of God;
- Liability for damage to property, or injury to, or death of any person arising out of the operation, maintenance or use of the covered product;
- Products with missing or altered serial numbers;

The original purchaser's sole and exclusive remedy against Meyer Products and its Distributors and Sub-Distributors, and Meyer Products' sole obligation for any and all claims, whether for breach of contract, warranty, tort (including negligence) or otherwise shall be limited to providing, through its authorized Distributor/Sub-Distributor network, all labor and/or parts necessary to correct such defects free of charge. Any cost incurred in returning the product to an authorized Meyer® Distributor/Sub-Distributor is the responsibility of the original purchaser. ALL EXPRESS AND IMPLIED WARRANTIES FOR THE PRODUCT, INCLUDING, WITHOUT LIMITATION, ANY IMPLIED WARRANTIES OF MERCHANTABILITY AND FITNESS FOR A PARTICULAR PURPOSE, ARE LIMITED IN TIME TO THE TERM OF THE LIMITED WARRANTY PERIOD. NO WARRANTIES, WHETHER EXPRESS OR IMPLIED, WILL APPLY AFTER THE LIMITED WARRANTY PERIOD HAS EXPIRED. Meyer Products disclaims liability beyond the remedies provided for in this limited warranty, and disclaims all liability for incidental, consequential, and special damages, including, without limitation, any liability for third-party claims against you for damages, for products not being available for use, or for lost profits. Meyer Products' liability will be no more than the amount you paid for the product that is the subject of a claim; this is the maximum amount for which we are responsible. Some states do not allow the exclusion or limitation of incidental or consequential damages, so the above limitation or exclusion may not apply to you. A complete Blaster Spreader Package consists of the Spreader Assembly, operating controller, Spreader Frame and all related items. Structural elements consist of the Spreader Frame, Mounting and Poly Hopper.



# Meyer® Blaster Spreader Warranty

Meyer Products will repair any product that proves to be defective in materials or workmanship. In the event repair is not possible or practical (as determined by Meyer Products in its sole discretion), Meyer Products will either replace the product with a new product of similar model and price, or refund the full purchase price, as determined by Meyer Products.

Customer must keep the complete Blaster Spreader Package serviced/maintained as recommended by Meyer Products. A written record of service must be maintained, along with receipts for maintenance materials purchased. A copy of the maintenance record and pertinent receipts may be requested in the event of a claim.

In order to obtain service under this warranty, the original purchaser must:

- Use all reasonable means to protect the complete Blaster Spreader package from further damage;
- Contact your local Meyer® or Aebi-Schmidt dealer from whom the product was purchased or to any authorized Meyer® or Aebi-Schmidt dealer. Transportation and freight charges prepaid when applicable. Only Meyer® and Aebi-Schmidt dealers are authorized to perform the obligations under this warranty. For the address and telephone number of the Meyer® or Aebi-Schmidt dealer nearest you visit <https://www.meyerproducts.com/dealer-locator>.
- Provide maintenance record and receipts for required maintenance, if requested;
- Allow inspection of damaged parts and/or complete Blaster Spreader package if deemed necessary by Meyer Products.
- It is the responsibility of the original purchaser to establish the warranty period by verifying the original delivery date. A bill of sale/sales receipt, cancelled check or some other appropriate payment record may be kept for that purpose.

This warranty gives you specific legal rights, and you may also have other rights which vary from state to state.

# Meyer<sup>®</sup> Snow Plows Limited Warranty

**What is Covered:** Meyer Products, LLC, warrants to the original purchaser of Meyer<sup>®</sup> brand products that they will be free from defects in materials or workmanship, with the exceptions stated below. No person is authorized to change this warranty or to create any additional warranty on Meyer<sup>®</sup> products.

**How Long Coverage Lasts:** This warranty runs for a period of two years from the date of purchase on any purchase of a complete Snow Plow Package<sup>1</sup>. If the snow plow is registered online at [www.meyerproducts.com](http://www.meyerproducts.com) within sixty (60) days of purchase, your warranty for the Package will be extended for a period of three years. In addition to the warranties covering a complete Snow Plow Package<sup>1</sup> and Structural Steel<sup>2</sup>, you will receive a warranty for a period of one year from the date of purchase on individual parts, components, and accessories. All foregoing warranties apply only to an original purchaser of the product if the product is installed by an authorized Distributor/Sub-Distributor and terminate if the product is sold or otherwise transferred. Some states do not allow limitations on how long an implied warranty lasts, so the above limitation may not apply to you.

**What is Not Covered:** This warranty does not cover:

- Problems caused by failure to follow the product instructions, failure to maintain the product as described in the Operator's Manual, or failure to maintain proper levels of fluids and lubricants.
- Problems caused by contamination or restriction of lubricant systems or damage resulting from rust, corrosion, freezing, or overheating.
- Paint or expendable snow plow parts such as pins, runners, cutting edges, chrome plating, springs, and markers.
- Damage to any vehicle to which the products are mounted or the suitability of any product for vehicles which are not fitted with the appropriate heavy-duty snow plow service preparation parts.
- Damage caused by usage that is not in accordance with product instructions (use of the snow plow for any purpose other than plowing snow is considered misuse and abuse).
- Any snow plow, part, component, or assembly thereof, which has been modified or altered.
- Problems caused by using accessories, parts, or components not supplied by Meyer Products.
- Cost of tax, freight, transportation, storage charges, environmental charges, solvents, sealants, lubricants, or any other normal shop supplies.
- Cost of gas, lodging, mileage, or any other incidental costs incurred with installation, maintenance, transportation, of the snow plow.
- Problems caused by collision, fire, theft, vandalism, riot, explosion, lightning, earthquake, windstorm, hail, water, flood, or any other Acts of God.
- Liability for damage to property, injury to, or death of any person arising out of the operation, maintenance or use of the covered product.
- Products with missing or altered serial numbers.

The original purchaser's sole and exclusive remedy against Meyer Products and its Distributors and Sub-Distributors, and Meyer Products' sole obligation for any and all claims, whether for breach of contract, warranty, tort (including negligence) or otherwise shall be limited to providing, through its authorized Distributor/Sub-Distributor network, all labor and/or parts necessary to correct such defects free of charge. Any cost incurred in returning the product to an authorized Meyer<sup>®</sup> Distributor/Sub-Distributor is the responsibility of the original purchaser.

<sup>1</sup>A complete Snow Plow Package consists of the hydraulic motor, operating controller, lift-frame, moldboard and all related items.

<sup>2</sup>Structural elements consist of the mounting, lift-frame, A-frame, sector, and the moldboard.

# Meyer® Snow Plows Limited Warranty

ALL EXPRESS AND IMPLIED WARRANTIES FOR THE PRODUCT, INCLUDING, WITHOUT LIMITATION, ANY IMPLIED WARRANTIES OF MERCHANTABILITY AND FITNESS FOR A PARTICULAR PURPOSE, ARE LIMITED IN TIME TO THE TERM OF THE LIMITED WARRANTY PERIOD. NO WARRANTIES, WHETHER EXPRESS OR IMPLIED, WILL APPLY AFTER THE LIMITED WARRANTY PERIOD HAS EXPIRED. Meyer Products disclaims liability beyond the remedies provided for in this limited warranty, and disclaims all liability for incidental, consequential, and special damages, including, without limitation, any liability for third-party claims against you for damages, for products not being available for use, or for lost profits. Meyer Products' liability will be no more than the amount you paid for the product that is the subject of a claim; this is the maximum amount for which we are responsible. Some states do not allow the exclusion or limitation of incidental or consequential damages, so the above limitation or exclusion may not apply to you.

**What Meyer Products Will Do:** Meyer Products will repair any product that proves to be defective in materials or workmanship. In the event repair is not possible or practical (as determined by Meyer Products in its sole discretion), Meyer Products will either replace the product with a new product of similar model and price, or refund the full purchase price, as determined by Meyer Products.

**Customer Responsibilities:** Customer must keep the complete Snow Plow Package serviced/maintained as recommended by Meyer Products. A written record of service must be maintained, along with receipts for maintenance materials purchased. A copy of the maintenance record and pertinent receipts may be requested in the event of a claim.

**How to Get Service:** In order to obtain service under this warranty, the original purchaser must:

- Use all reasonable means to protect the complete snow plow package from further damage.
- Contact your local Meyer® or Aebi-Schmidt dealer from whom the product was purchased or to any authorized Meyer® or Aebi-Schmidt dealer. Transportation and freight charges prepaid when applicable. Only Meyer® and Aebi-Schmidt dealers are authorized to perform the obligations under this warranty. For the address and telephone number of the Meyer® or Aebi-Schmidt dealer nearest you visit <https://www.meyerproducts.com/dealer-locator>.
- Provide maintenance record and receipts for required maintenance, if requested.
- Allow inspection of damaged parts and/or complete snow plow package if deemed necessary by Meyer Products, Meyer® dealer, or Aebi-Schmidt dealer.
- It is the responsibility of the original purchaser to establish the warranty period by verifying the original delivery date. A bill of sale/sales receipt, cancelled check, or some other appropriate payment record may be kept for that purpose.

**How State Law Applies:** This warranty gives you specific legal rights, and you may have other rights which vary from state to state.

<sup>1</sup>A complete Snow Plow Package consists of the hydraulic motor, operating controller, lift-frame, moldboard and all related items.

<sup>2</sup>Structural elements consist of the mounting, lift-frame, A-frame, sector, and the moldboard.

# Meyer<sup>®</sup> HomePlow Limited Warranty

## THE HOMEPLOW SNOW PLOW LIMITED WARRANTY EFFECTIVE May 1, 2010

The HomePlow, warrants to the original purchaser of HomePlow brand products that they will be free from defects in materials or workmanship for a period of one year from date of purchase to only the original owner.

This warranty does not cover:

- Problems caused by failure to follow the product instructions, failure to maintain the product as described in the Operator's Manual, or failure to maintain proper levels of lubricants;
- Problems caused by contamination or restriction of lubricant systems, or damage resulting from rust, corrosion, freezing or overheating;
- Paint, or expendable snow plow parts such as pins, wheels, cutting edges, chrome plating and springs;
- Damage to any vehicle to which the products are mounted;
- Damage caused by usage that is not in accordance with product instructions, usage in an commercial or heavy duty environment (use of the snow plow for any purpose other than plowing snow is considered misuse and abuse);
- Any snow plow, or any part which has been modified or altered;
- Problems caused by using accessories, parts, or components not supplied by The HomePlow,
- Cost of tax, freight, transportation or storage charges, environmental charges, solvents, sealants, lubricants or any other normal shop supplies.
- Problems caused by collision, fire, theft, vandalism, riot, explosion, lightning, earthquake, windstorm, hail, water, flood, or any other Acts of God;
- Liability for damage to property, or injury to, or death of any person arising out of the operation, maintenance or use of the covered product;
- Products with missing or altered serial numbers;

The HomePlow will repair any product that proves to be defective in materials or workmanship. In the event repair is not possible or practical (as determined by The HomePlow in its sole discretion), The HomePlow will either replace the product with a new product of similar model and price, or refund the full purchase price, as determined by The HomePlow.

Customer must keep the HomePlow System serviced/maintained as recommended by The HomePlow. A written record of service must be maintained, along with receipts for maintenance materials purchased. A copy of the maintenance record and pertinent receipts may be requested in the event of a claim.

In order to obtain service under this warranty, the original purchaser must:

- Return the claimed defective part to any authorized The HomePlow Dealer, transportation and freight charges prepaid. Only The HomePlow Dealers are authorized to perform the obligations under this warranty. For the address and telephone number of The HomePlow Dealer nearest you, check the telephone directory, go to **[www.thehomeplow.com](http://www.thehomeplow.com)**, write us at the address to the left, or call (877) 412-PLOW (7569) for assistance;
- Provide maintenance record and receipts for required maintenance, if requested;
- Allow inspection of damaged parts and/or HomePlow System if deemed necessary by The HomePlow.
- It is the responsibility of the original purchaser to establish the warranty period by verifying the original delivery date. A bill of sale/sales receipt, cancelled check or some other appropriate payment record may be kept for that purpose.

<sup>1</sup>A complete Snow Plow Package consists of the hydraulic motor, operating controller, lift-frame, moldboard and all related items.

<sup>2</sup>Structural elements consist of the mounting, lift-frame, A-frame, sector, and the moldboard.

# EC Declaration of Conformity

For our product  
Machine:

Super V3, Drive Pro, Nite Saber Lights, Crossfire, Elite, Hot Shot, Blaster, Base Line

Type:

Plow  
Tailgate Spreader  
Insert Spreader  
Walk Behind Spreader

Directives:

We hereby declare that it has been designed and manufactured in accordance with the following directives:

2006/42/EC	EC Low Voltage Directive
2004/108/EC	EMC Directive
2006/42/EC	Machinery Directive

Corresponding documentation can be provided on request. Authorized person for doing this is:

Meyer Products  
18513 Euclid Avenue  
Cleveland, OH 44112-1084  
216-486-1313

Standards:

Following standards have been respected:

- BS EN 60204-1:2006/IEC 60204-1:2005: Safety of Machinery-Electrical Equipment of Machines-Part 1 General Requirements
- EN ISO 12100-1:2003: Safety of Machinery-Basic Concepts, General Principles of Design Part1: Basic Terminology and Methodology
- EN ISO 12100-2:2003: Safety of Machinery-Basic Concepts, General Principles of Design Part 2: Technical Principles
- EN 13021:2003+A1-Winter Service Machines-Safety Requirements
- EN 61000-6-2:2005-Generic Standards-Immunity for Industrial Environments
- EN 61000-6-4:20058-Generic Emission Standard, Part 2: Industrial Environment

In case of modification of the machine, not in consultation with Aebi Schmidt, this Declaration of Conformity becomes invalid.

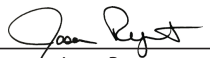
  
Jason Ryant  
Operations

  
Jason Bartuseck  
General Manager Meyer

# Meyer Genuine Parts

Meyer Genuine Parts are designed to fit properly and perform better and last longer – which means you save money by replacing fewer parts less often. In addition, all Meyer Genuine Parts..:

- Comply with Meyer specifications and technical standards
- Maintains the warranty on your original equipment
- Fit perfectly and reduces installation time
- Guarantee original equipment quality

Look for the Meyer name on all your replacement parts.

For more information, visit [www.meyerproducts.com](http://www.meyerproducts.com)



# Notes

# Jeep®



**MOPAR.**

**OFFICIAL  
LICENSED  
PRODUCT**

MOPAR, RAM, Jeep, and related logos, vehicle model names and trade dress are trademarks of FCA US LLC used under license by Meyer Products LLC.  
© 2020 FCA US LLC

Meyer Products LLC  
18513 Euclid Avenue  
Cleveland, OH 44112-1084  
216-486-1313  
[www.meyerproducts.com](http://www.meyerproducts.com)



a brand of aebi schmidt

Form#4-567

Part# 90965

1020