

PARTS & INSTALLATION INSTRUCTIONS





MEYER SNOW PLOW MOUNTING CARTON 17170

2003 & LATER FORD F-650 & F-750

2003 & LATER INTERNATIONAL 4200/4300/4400



End user must be given this instruction sheet prior to delivery of this Snow Plow.

SAFETY DEFINITIONS



	This is the safety alert symbol. It is used to alert you to potential personal injury hazards. Obey all safety messages that follow this symbol to avoid possible injury or death.
	DANGER Indicates an imminently hazardous situation which, if not avoided, will result in death or serious injury.
	WARNING Indicates a potentially hazardous situation which, if not avoided, could result in death or serious injury.
	CAUTION Indicates an potentially hazardous situation which, if not avoided, may result in minor or moderate injury.
	CAUTION used without the safety alert symbol indicates a potentially hazardous situation which, if not avoided, will result in property damage.

IMPORTANT NOTICE

In conjunction with FMVSS (Federal Motor Vehicle Safety Standards) and OEM (Original Equipment Manufacturer) guidelines, Meyer Products has designed this plow package with the following guidelines:

	Installation of a snowplow may effect your new vehicle warranty. For more information consult your Vehicle Owner's Manual / Vehicle Dealer.
	The vehicle must not be operated when overloaded. In all cases, the loaded vehicle weight, including the entire snowplow system, all aftermarket accessories, driver, passenger, options, nominal fluid levels, and cargo must not exceed the front/rear Gross Axle Weight Rating (GAWR), and total Gross Vehicle Weight Rating (GVWR). These weights ratings are specified on the safety compliance certification label on the driver's side door opening. The use of rear ballast weight may be required to prevent exceeding the front GAWR.

According to the NHTSA (National Highway Traffic Safety Administration) new and untitled vehicles need to be verified by the installer that snowplow and ballast (if needed) do not exceed the front/rear GAWR and total GVWR.

	 Read the Meyer Owner's Manual before operating or servicing a snowplow. FOLLOW THESE INSTRUCTIONS EXPLICITLY.
---	--

GENERAL INFORMATION

	SAFETY PRECAUTIONS should be used when Hydraulic Unit is in OPERATION and plow is in a RAISED position. Lower plow to ground when vehicle is PARKED in case of hydraulic failure.
---	---

Check contents against the parts list to determine all are correct and included, and also to familiarize yourself with them.

	Warranty does not apply to a Meyer or Diamond product which has been negligently or improperly assembled or installed.
---	--

	CAUTION: To avoid harm to vehicles electrical system always disconnect battery before beginning installation. DO NOT BURN holes or WELD vehicle frame. This may cause frame failure.
---	---

OVERHAUL and SERVICE INFORMATION are covered on separate instructions.

Meyer Products LLC reserves the right, under its continuing product improvement program, to change construction or design details, specifications and prices without notice or without incurring any obligation.

Meyer Products LLC 18513 Euclid Ave. • Cleveland, Ohio 44112-1084 Phone (216) 486-1313 www.meyerproducts.com • email info@meyerproducts.com
--

PARTS LIST



Item	Part No.	Qty.	Description
	17170	1	MOUNTING CARTON
1	19967	1	• Lift Frame
2	19623	1	• LH Anchor Assy.
3	19622	1	• RH Anchor Assy.
4	19305	1	• LH Clevis Weld (2003-2015)
4	14284	1	• LH Clevis Weld (2016-Later)
5	19272	1	• RH Clevis Weld (2003-2006)
5	14283	1	• RH Clevis Weld (2016-Later)
5	19930	1	• RH Clevis Weld (2007-2015)
6	19935	1	• LH Angle
7	19934	1	• RH Angle
8	19325	1	• Cross Angle
9	14219	1	• Lift Arm
	08211	1	• HARDWARE BAG
10	10797	4	•• Spacer 1/4 x 1-1/2"
11	20144	1	•• Bolt H 5/8-11 x 2-3/4" Gr.5
12	20146	2	•• Bolt H 5/8-11 x 3-1/4" Gr.5
13	20166	14	•• Bolt H 3/4-10 x 2-1/2" Gr. 5
14	22653	2	•• Bolt H 1-8 x 2-1/2" Gr. 5
15	20309	3	•• Locknut Esna 5/8-11
16	20310	14	•• Locknut Esna 3/4-10
17	22493	2	•• Locknut Esna 1-8
18	22324	2	•• Clevis Pin
19	22083	2	•• Lynch Pin
20	22460	1	•• Elbow 90 Degree SAE 6

IMPORTANT

After first use, retighten all mounting bolt connections to specified torque. All mounting bolt connections to be checked periodically for tightness.

Locknuts are furnished **DO NOT** tighten bolts and nuts until installation is complete (unless otherwise specified), then be sure to tighten all attaching parts per specified torque chart.

TORQUE CHART FOOT

Bolt Nut Size	Gr. 2 	Gr. 5 	Gr. 8 
1/4 - 20	4 - 5		
5/16 - 18	9 - 11		
3/8 - 16	17 - 20	26 - 29	
7/16 - 14		42 - 46	60 - 66
1/2 - 13		64 - 72	90 - 100
5/8 - 11		127 - 141	179 - 198

Parts indented are included in the carton, bag or assembly under which they are indented.

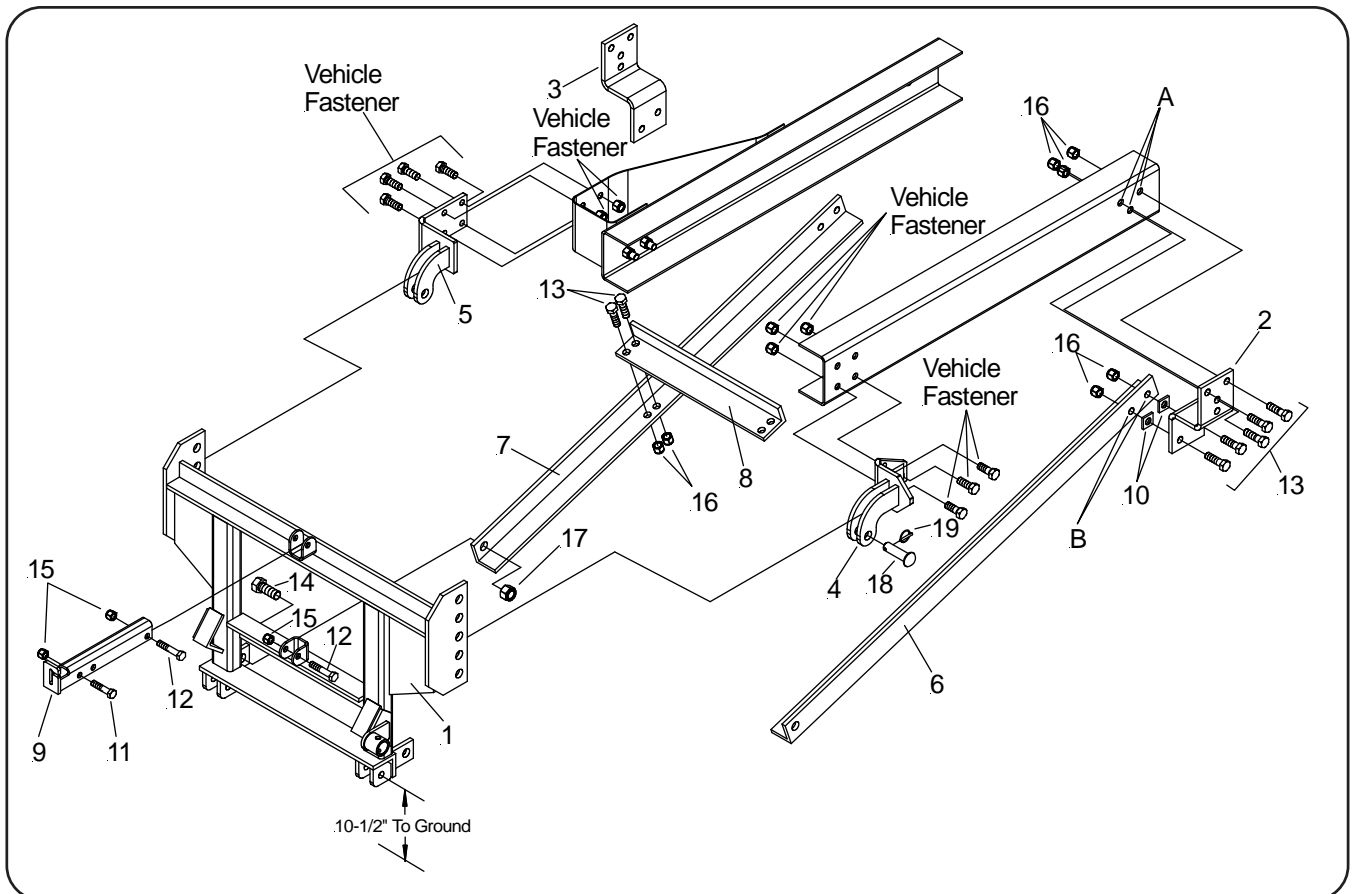

VEHICLE RECOMMENDATIONS

⚠ WARNING

- Front end wheel alignment and headlight aim may require readjustment after installation of equipment, and is the responsibility of the equipment installer. Failure to adjust front wheel alignment may cause premature uneven tire wear. If required, reset to chassis manufacturer's specifications found in the Ford Shop Manual.

Rear ballast is determined by weighing a vehicle's front and rear axles and adding weight behind the rear axle until front axle weight is under or equal to the vehicle specific front GAWR while not exceeding the rear GAWR and GVWR.

Vehicle option packages may vary. If in doubt, it is always a good idea to weigh the vehicle to ensure all weight ratings are not exceeded with plow in the raised position.

INSTALLATION INSTRUCTIONS

- Remove bumper. Retain fasteners, bumper will be reinstalled.
- Remove tow hooks, they will not be reinstalled Retain fasteners, they will be reused.
- Install LH (4) and RH clevises using original vehicle tow hook bolts. The clevises will take the places of the tow hooks. Tighten fasteners for clevises LH (4) and RH (5) at this time.
- Reinstall bumper.
- Hang lift frame (1) from LH (4) and RH (5) clevises using 1" diameter Pins (18) and Lynch pins (19). Pin in proper hole on lift frame so that the center line of the bottom clevis hole is closest to 10-1/2" from the ground. Make sure that the lift frame stays vertical by checking it with a level and clamping it in place.
- Bolt LH (6) and RH (7) angles to tabs with 1" diameter holes on the back near the bottom of the lift frame using 1-8 x 2-1/2" hex bolts (14) and 1-8 locknuts (17). Do not tighten at this time.

Note: It will be necessary to trim the rear brace angle on the driver's side in order to avoid interference with the nearby oil reservoir. The amount to trim depends upon which hole the lift frame was hung in to get the correct height. It is important to locate the Anchor Assemblies in step H before trimming. The passenger side can be trimmed to match the length of the driver's side if desired.

- Position LH (2) & RH (3) Anchor Assemblies against bottom of frame as shown near ends of LH (6) and RH (7) Angles. The Anchor Assemblies should just fit into place to the rear of two vertically in line bolt heads and in front of an anchor for the wiring harness on the sides of the frame. If necessary the wiring harness anchor can be cut to remove. The wires should be tie wrapped in place after the mounting has been installed.

- Push up and clamp Anchor Assemblies against bottom of frame. Mark location of the three holes (A) on top part of Anchor Assemblies on the frame. Remove Anchor Assemblies and drill three 13/16" diameter holes on each side of the frame. Bolt Anchor Assemblies to vehicle frame using 3/4-10 x 2-1/2" hex bolts (13) and 3/4-10 locknuts (16).
- Mark locations of lower holes (B) in Anchor Assemblies onto Angles and drill two 13/16" diameter holes in each of the two Angles. Bolt Anchor Assemblies to Angles using 3/4-10 x 2-1/2" hex bolts (13) and 3/4-10 locknuts (16).
- Connect Cross Angle (8) to Angles (6 & 7) using 3/4-10 x 2-1/2" hex bolts (13) and 3/4-10 locknuts (16).
- Connect Lift Arm (9) (and hydraulic unit) to Lift Frame (1) using 5/8-11 x 3-1/4" hex bolts (12) and locknuts (15). Connect Lift Arm (9) to hydraulic unit using 5/8-11 x 2-3/4" hex bolts (11) and locknuts (15).
- Tighten fasteners in order of their assembly.
- While installing hydraulics note that Male SAE Elbow (20) will need to be installed. Between the female coupler and the end of the angling hose as shown below.

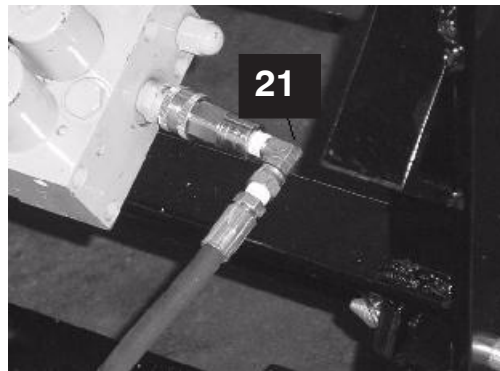

Meyer Products assumes no responsibility for installations not made in accordance with these instructions.