



PARTS & INSTALLATION INSTRUCTIONS

EZ MOUNT PLUS™

SNOW PLOW MOUNTING 17165

2007 & Later GMC and CHEVROLET K SERIES

K1500 SERIES 4x4 MODELS

"SUV" SERIES NON-COMMERCIAL for PERSONAL USE ONLY

End user must be given this instruction sheet prior to delievery of this Snow Plow.

SAFETY DEFINITIONS

	This is the safety alert symbol. It is used to alert you to potential personal injury hazards. Obey all safety messages that follow this symbol to avoid possible injury or death.
	DANGER Indicates an imminently hazardous situation which, if not avoided, will result in death or serious injury.
	WARNING Indicates a potentially hazardous situation which, if not avoided, could result in death or serious injury.
	CAUTION Indicates an potentially hazardous situation which, if not avoided, may result in minor or moderate injury.
	CAUTION used without the safety alert symbol indicates a potentially hazardous situation which, if not avoided, will result in property damage.

IMPORTANT NOTICE

In conjunction with FMVSS (Federal Motor Vehicle Safety Standards) and OEM (Original Equipment Manufacturer) guidelines, Meyer Products has designed this plow package with the following guidelines:

	Installation of a snowplow may effect your new vehicle warranty. For more information consult your Vehicle Owner's Manual / Vehicle Dealer.
	The vehicle must not be operated when overloaded. In all cases, the loaded vehicle weight, including the entire snowplow system, all aftermarket accessories, driver, passenger, options, nominal fluid levels, and cargo must not exceed the front/rear Gross Axle Weight Rating (GAWR), and total Gross Vehicle Weight Rating (GVWR). These weights ratings are specified on the safety compliance certification label on the driver's side door opening. The use of rear ballast weight may be required to prevent exceeding the front GAWR.

According to the NHTSA (National Highway Traffic Safety Administration) new and untitled vehicles need to be verified by the installer that snowplow and ballast (if needed) do no exceed the front/rear GAWR and total GVWR.

	Read the Meyer Owner's Manual before operating or servicing a snowplow. FOLLOW THESE INSTRUCTIONS EXPLICITLY.
--	--

GENERAL INFORMATION

	SAFETY PRECAUTIONS should be used when Hydraulic Unit is in OPERATION and plow is in a RAISED position. Lower plow to ground when vehicle is PARKED in case of hydraulic failure.
--	---

Check contents against the parts list to determine all are correct and included, and also to familiarize yourself with them.

	Warranty does not apply to a Meyer or Diamond product which has been negligently or improperly assembled or installed.
--	--

	CAUTION: To avoid harm to vehicles electrical system always disconnect battery before beginning installation. DO NOT BURN holes or WELD vehicle frame. This may cause frame failure.
--	---

OVERHAUL and **SERVICE INFORMATION** are covered on separate instructions.

Meyer Products and Diamond Equipment reserves the right, under its continuing product improvement program, to change construction or design details, specifications and prices without notice or without incurring any obligation.

Meyer Products LLC
18513 Euclid Ave. • Cleveland, Ohio 44112-1084
Phone (216) 486-1313
www.meyerproducts.com • email info@meyerproducts.com



PARTS LIST

ITEM	PART NO.	QTY	DESCRIPTION		
	17165	1	MOUNTING CARTON		
1	19747	1	• L.H. Side Mount		
2	19748	1	• R.H. Side Mount		
3	19746	1	• Underframe Weld		
4	19750	1	• Handle 20" Bolt 5/8-11 x 1-1/2" Gr.5		
5	19752	1	• Handle 4" Bolt 5/8-11 x 1-1/2" Gr.5		
	08133	1	• HARDWARE BAG		
6	20096	8	• Bolt H 1/2-13 x 1-3/4" Gr.5		
7	20141	2	• Bolt H 5/8-11 x 2" Gr. 5		
8	20307	12	• Locknut Esna 1/2-13		
9	20309	4	• Locknut Esna 5/8-11		
10	20108	4	• Bolt H 1/2-13 x 5-1/2" Gr. 5		
11	20355	8	• Flatwasher 1/2"		
	21976	2	• Battery Connectors		
*	19370	1	Universal Clevis (Part of Plus CLF Carton)		
**	11770	1	Universal Clevis (Part of MDII CLF Carton)		
11" SECTOR		MEYER			
	PART NO.	QTY.	PART NO.	QTY.	DESCRIPTION
	16520	1	16515	1	Sector A-Frame Carton
DIAMOND					
			81504	1	Common Attaching Kit
			81026	1	Push Frame

Parts indented are included in the carton, bag or assembly under which they are indented.

IMPORTANT

After first use, retighten all mounting bolt connections to specified torque. All mounting bolt connections to be checked periodically for tightness.

Locknuts are furnished **DO NOT** tighten bolts and nuts until installation is complete (unless otherwise specified), then be sure to tighten all attaching parts per specified torque chart.

TORQUE CHART FOOT

Bolt Nut Size	Gr. 2	Gr. 5	Gr. 8
1/4 - 20	4 - 5		
5/16 - 18	9 - 11		
3/8 - 16	17 - 20	26 - 29	
7/16 - 14		42 - 46	60 - 66
1/2 - 13		64 - 72	90 - 100
5/8 - 11		127 - 141	179 - 198

NOTE:

THIS MOUNTING CARTON CAN BE USED WITH THE MDII OR EZ MOUNT PLUS CLF CARTONS.

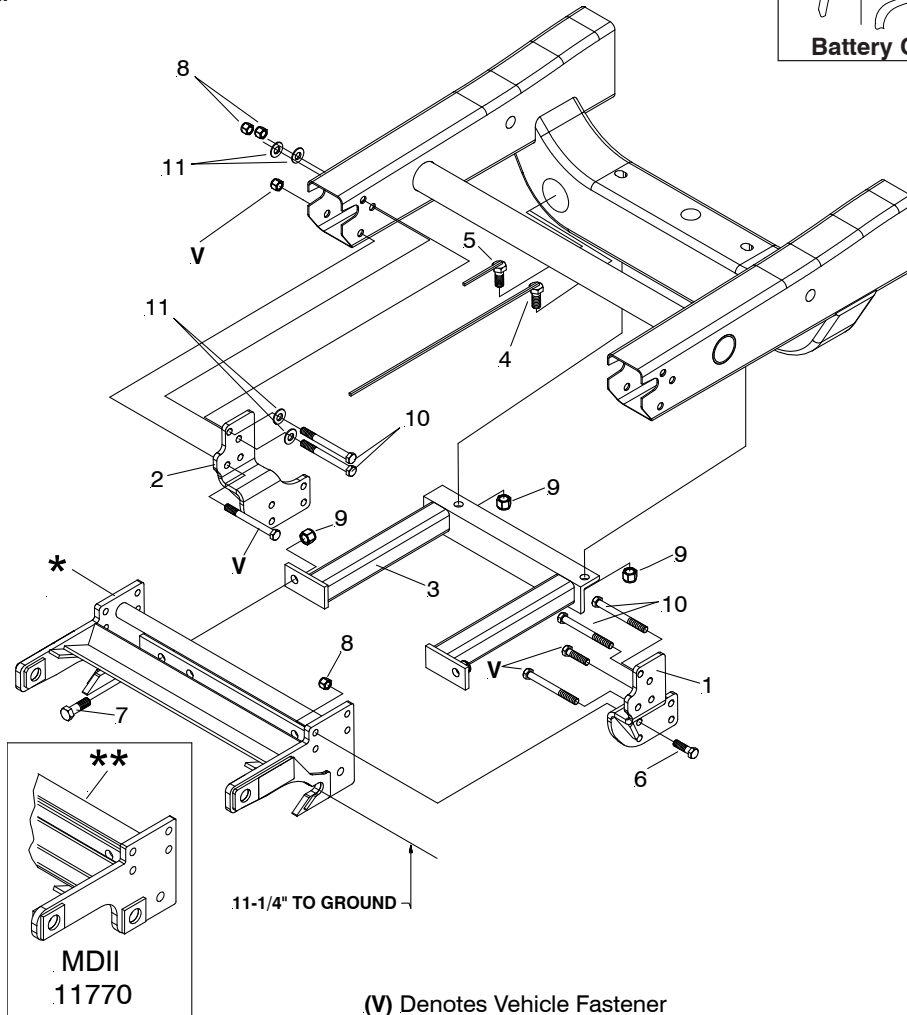
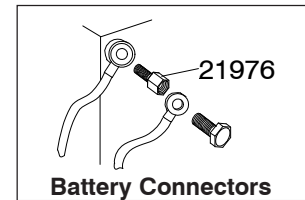

VEHICLE RECOMMENDATIONS

General Motors Corp.

General Motors recommends snowplow usage for only those trucks that have the option "VYU" Snow Plow Preparation Package.

Model - K1500 G.V.W. Opt.Code Frt. G.V.W.R.

Reg. Cab only

119" W.B. 2007-cur. 6100 lb. (C5M) 3925 lb.

133" W.B. 2007-cur. 6400 lb. (C7H) 3925 lb.

Vehicles Not Recommended by GM:

1500 Extended Cab Pickups

1500 Chevy Avalanche

1500 Chevy Tahoe/Suburban

1500 GMC Yukon/Yukon Denali

1500 GMC Sierra Denali (AWD)

Cadillac Escalade/ Escalade EXT

- Due to weight restrictions on vehicle's front GAWR, a STL-7.5 moldboard is the largest that can safely be installed on a Tahoe, Yukon, Avalanche and Suburban.

General Motors recommends that when a snow plow is mounted that only one passenger should accompany the driver. More than one passenger may exceed front gross axle weight ratings.

- A ballast weight may be required to prevent front GAWR overloading. If required, ballast must be securely attached at least 24 inches behind the rear axle.
- Front end wheel alignment and headlight aim may require readjustment after installation of equipment, and is the responsibility of the equipment installer. Failure to adjust front wheel alignment may cause premature uneven tire wear. If required, reset to chassis manufacture's specifications found in the GM Shop Manual.

Rear ballast is determined by weighing a vehicle's front and rear axles and adding weight behind the rear axle until front axle weight is under or equal to the vehicle specific front GAWR while not exceeding the rear GAWR and GVWR.

Vehicle option packages may vary. If in doubt, it is always a good idea to weigh the vehicle to ensure all weight ratings are not exceeded with plow in the raised position.

INSTALLATION INSTRUCTIONS

- Remove air dam. Retain all hardware. The air dam may be reinstalled.
- Remove splash shield. Retain. It will not be reused. Hardware will not be reused.
- Remove tow hooks bolts from both driver and passenger side frame rails. Retain, they will be reused.
- Position the L.H. & R.H. Side Mounts (1 & 2) to the inside of vehicle frame and align holes to where tow hook bolts were removed. Attach Side Mounts to upper tow hook holes using Bolt H 1/2-13 x 5-1/2" (10), 1/2" Flatwasher (11) and 1/2-13 Locknut (8). On bottom holes use the original tow hook fasteners. **Note: Snug all bolts during the installation. Do not torque down any bolts until step I.**

Note: When installing on an S.U.V the frame is slightly different. The vehicle bracket lip must be trimmed for L.H. & R.H. Side Mounts (1 & 2) to fit flush to vehicle frame (see picture below)

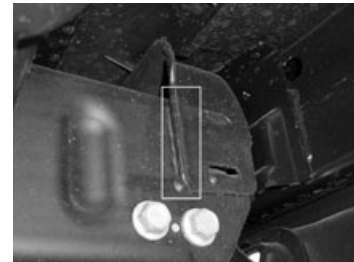

The upper holes (A) must be drilled. Using the L.H. & R.H. Side Mounts (1 & 2) as a template drill 2 holes 9/16" diameter thru the vehicle frame and fasten using Bolt H 1/2-13 x 5-1/2" (10), 1/2" Flatwasher (11) and 1/2-13 Locknut (8). On bottom holes use the original tow hook fasteners.

- Attach the Universal Clevis (*) between the LH & RH Side Mounts (1&2) using four 1/2-13 x 1-3/4" bolts (6), and 1/2" locknuts (8) on each side.
- Position underframe (3) behind the universal clevis frame's bottom angle. Attach underframe (3) to the Universal Clevis (*), using 5/8-11 x 2" bolts (7) and 5/8-11 locknuts (9).
- Attach rear of underframe (3) to the two holes in the vehicle crossmember. All bolts must be installed thru the opening on right side of vehicle crossmember. Attach to the left hole in vehicle crossmember using 20" Handle Bolt (4) and 5/8-11 locknut (9). It will be necessary to bend the handle in order to fit inside the frame. Attach to the right hole in vehicle crossmember using 4" Handle Bolt (5) and 5/8-11 locknut (9).

Note: Before tightening the fasteners, the Clevis Frame (*) should be level with the ground and pushed back as far under the vehicle as possible.

- Tighten all fasteners to their proper torque. Tighten bolts in the same order they were assembled to the vehicle.
- Reinstall bumper if removed. Reinstall air dam if desired, notch out around clevis frame as needed.
- Install remaining snowplow hardware per separate instructions.