



PARTS & INSTALLATION INSTRUCTIONS

MDII™ and EZ MOUNT PLUS™

SNOW PLOW MOUNTING

2005 & LATER GMC 4500/5500 4 X 4

End user must be given this instruction sheet prior to delivery of Snow Plow.

SAFETY DEFINITIONS

	This is the safety alert symbol. It is used to alert you to potential personal injury hazards. Obey all safety messages that follow this symbol to avoid possible injury or death.
	DANGER Indicates an imminently hazardous situation which, if not avoided, will result in death or serious injury.
	WARNING Indicates a potentially hazardous situation which, if not avoided, could result in death or serious injury.
	CAUTION Indicates an potentially hazardous situation which, if not avoided, may result in minor or moderate injury.
	CAUTION used without the safety alert symbol indicates a potentially hazardous situation which, if not avoided, will result in property damage.

IMPORTANT NOTICE

In conjunction with FMVSS (Federal Motor Vehicle Safety Standards) and OEM (Original Equipment Manufacturer) guidelines, Meyer Products has designed this plow package with the following guidelines:

	Installation of a snowplow may effect your new vehicle warranty. For more information consult your Vehicle Owner's Manual / Vehicle Dealer.
--	---

	The vehicle must not be operated when overloaded. In all cases, the loaded vehicle weight, including the entire snowplow system, all aftermarket accessories, driver, passenger, options, nominal fluid levels, and cargo must not exceed the front/rear Gross Axle Weight Rating (GAWR), and total Gross Vehicle Weight Rating (GVWR). These weights ratings are specified on the safety compliance certification label on the driver's side door opening. The use of rear ballast weight may be required to prevent exceeding the front GAWR.
--	---

According to the NHTSA (National Highway Traffic Safety Administration) new and untitled vehicles need to be verified by the installer that snowplow and ballast (if needed) do no exceed the front/rear GAWR and total GVWR.

	Read the Meyer Owner's Manual before operating or servicing a snowplow. FOLLOW THESE INSTRUCTIONS EXPLICITLY.
--	--

GENERAL INFORMATION

	SAFETY PRECAUTIONS should be used when Hydraulic Unit is in OPERATION and plow is in a RAISED position. Lower plow to ground when vehicle is PARKED in case of hydraulic failure.
--	---

Check contents against the parts list to determine all are correct and included, and also to familiarize yourself with them.

	Warranty does not apply to a Meyer or Diamond product which has been negligently or improperly assembled or installed.
--	--

	CAUTION: To avoid harm to vehicles electrical system always disconnect battery before beginning installation. DO NOT BURN holes or WELD vehicle frame. This may cause frame failure.
--	---

OVERHAUL and SERVICE INFORMATION are covered on separate instructions.

Meyer Products and Diamond Equipment reserves the right, under its continuing product improvement program, to change construction or design details, specifications and prices without notice or without incurring any obligation.

Meyer Products Inc. 18513 Euclid Ave. • Cleveland, Ohio 44112-1084 Phone (216) 486-1313 www.meyerproducts.com • email info@meyerproducts.com

PARTS LIST

ITEM	PART NO.	QTY.	DESCRIPTION
	17158	1	MOUNTING CARTON
1	19597	1	• LH Push Plate Weld
2	19596	1	• RH Push Plate Weld
3	19619	1	• LH Brace
4	19618	1	• RH Brace
	08868	1	• HARDWARE BAG
5	22231	2	•• Bolt 12mm x 1.75P x 60mm Gr.5
6	20096	9	•• Bolt 1/2-13 x 1-3/4" Gr. 5
7	20098	1	•• Bolt 1/2-13 x 2-1/4" Gr. 5
8	20142	4	•• Bolt 5/8-11 x 2-1/4" Gr. 5
9	20164	2	•• Bolt 3/4-10 x 2" Gr. 5
10	20307	10	•• Locknut Esna 1/2-13
11	20309	4	•• Locknut Esna 5/8-11
12	20310	2	•• Locknut Esna 3/4-10
13	22257	4	•• Special Flatwasher 7/16"
14	20357	2	•• Flatwasher 5/8
15	20359	2	•• Flatwasher 3/4
*	19370	1	Universal Clevis (Part of Plus CLF Carton)
**	11770	1	Universal Clevis (Part of MDII CLF Carton)
	15" SAF		MEYER
	PART NO.	QTY.	DESCRIPTION
	16516	1	Sector A-Frame Carton
			Diamond
	81504	1	Common Attaching Kit
	81026	1	Push Frame

Parts indented are included in the carton, bag or assembly under which they are indented.

IMPORTANT

After first use, retighten all mounting bolt connections to specified torque. All mounting bolt connections to be checked periodically for tightness.

Locknuts are furnished **DO NOT** tighten bolts and nuts until installation is complete (unless otherwise specified), then be sure to tighten all attaching parts per specified torque chart.

TORQUE CHART FOOT

Bolt Nut Size	Gr. 2	Gr. 5	Gr. 8
1/4-20	4-5		
5/16-18	9-11		
3/8-16	17-20	26-29	
7/16-14		42-46	60-66
1/2-13		64-72	90-100
5/8-11		127-141	179-198

NOTE:

THIS MOUNTING CARTON CAN BE USED WITH THE MDII OR EZ MOUNT PLUS CLF CARTONS.

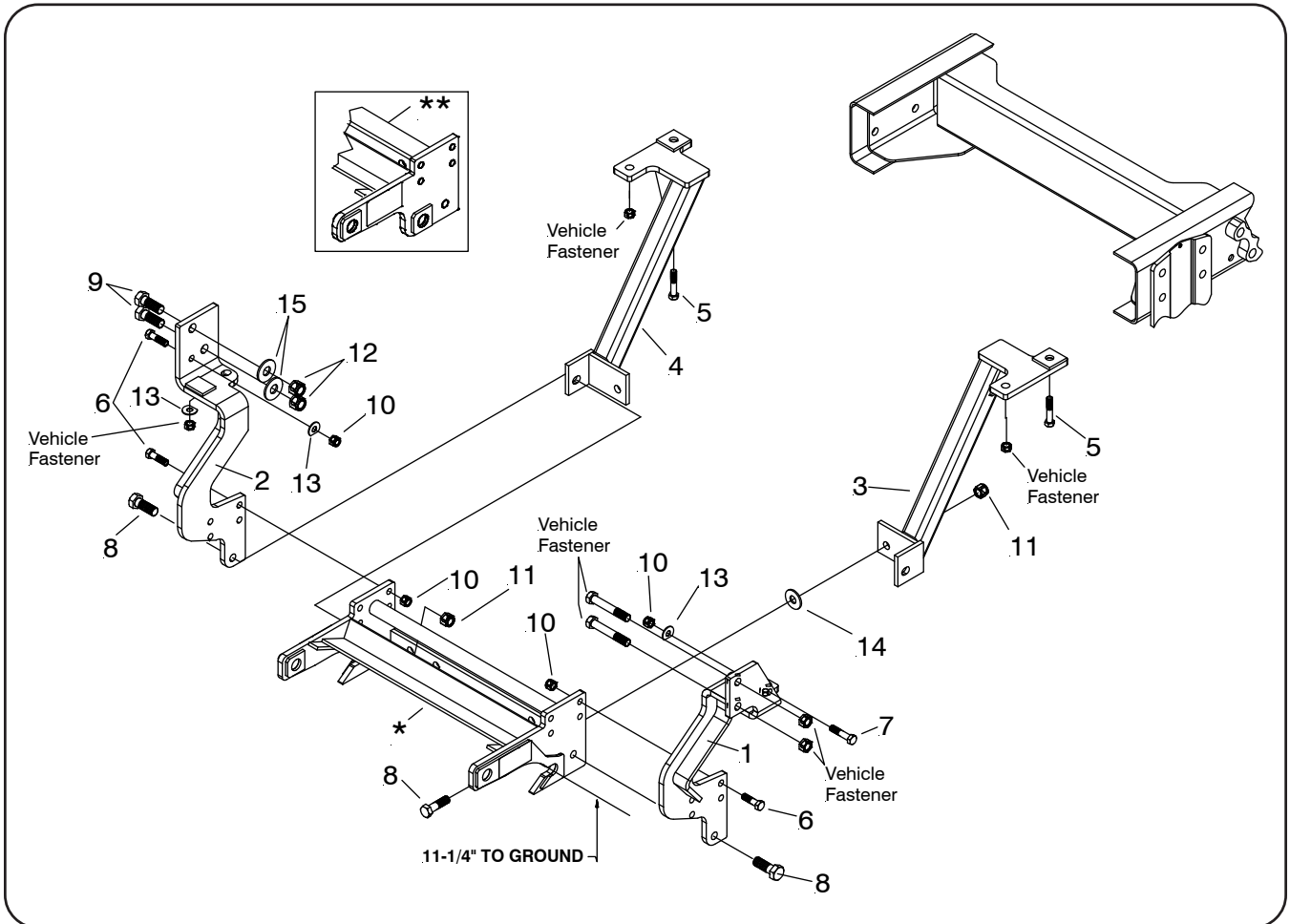

VEHICLE RECOMMENDATIONS

⚠WARNING

- Front end wheel alignment and headlight aim may require readjustment after installation of equipment, and is the responsibility of the equipment installer. Failure to adjust front wheel alignment may cause premature uneven tire wear. If required, reset to chassis manufacturer's specifications found in the GM Shop Manual.

Rear ballast is determined by weighing a vehicle's front and rear axles and adding weight behind the rear axle until front axle weight is under or equal to the vehicle specific front GAWR while not exceeding the rear GAWR and GVWR.

Vehicle option packages may vary. If in doubt, it is always a good idea to weigh the vehicle to ensure all weight ratings are not exceeded with plow in the raised position.

INSTALLATION INSTRUCTIONS

- A. Remove front bumper by removing four nuts on the back side.
- B. Remove four "vehicle fastener" bolts/nuts on driver's side that hold that hold the front leaf spring bracket/tow hook (if equipped). Retain all hardware, it will be reused. The tow hook will not be reinstalled.
- C. Remove underside cross member's front bolt with tube spacer and nut on each side. Position the LH Push Plate Weld (1) by the rear two holes in the frame. The front two vehicle bolts which are longer than the rear two vehicle bolts and may need to be used in the rear to install the LH Push Plate Weld (1). The rear two tow hook bolts can be reinstalled in the front holes.
- D. Attach rear hole of the LH Push Plate Weld (1) through frame using the 1/2-13 x 2-1/4 bolt (7), 7/16 special washer (13) and 1/2 locknut (10). Attach underside hole in the side member to the bottom of the frame using vehicle tube spacer and nut.
- E. Attach RH Push Plate Weld's (2) two large holes to the vehicle frame using 3/4-10 x 2" bolts (9), 3/4 washers (15) and 3/4 locknuts (12). Attach the smaller hole in the side to frame using 1/2-13 x 1-3/4 bolt (6), 7/16 special washer (13) and 1/2 locknut (10). Attach underside hole in the side member to the bottom of the frame using vehicle tube spacer and nut.
- F. Attach Clevis (*) between Push Plate Weld (1 & 2) using 1/2-13 x 1-3/4 bolts (6) and 1/2 Locknuts (10).
- G. Remove underside cross member's rear bolt with tube spacer and nut on each side. It may be necessary to make a special tool by cutting off an 18mm box wrench to approximately 2-1/2" long to accomplish this. Also remove next bolt to the rear on each side. These two bolts will not be reused.
- H. Install LH and RH Braces (3 & 4) using underside cross member's rear bolts with tube spacer and nut and 12mm x 1.75P x 60mm long bolts (5) at the rear. Insert 5/8 flat washer (14) between brace and rear of clevis. Fasten to Clevis using 5/8-11 x 2-1/4 bolts (8) and 5/8 locknuts (11).
- I. Tighten all fasteners to their proper torque. Tighten bolts in the same order they were assembled to the vehicle.
- J. Reinstall bumper using original hardware.

Meyer Products or Diamond Equipment assumes no responsibility for installations not made in accordance with these instructions.