

## Assembly Instructions

Standard Operating System with Hands Free Plowing

Includes  
Black Iron: 41670  
Moldboards: 79400K, 79401K, 79402K, 79403K



**NOTICE:** Meyer Products LLC reserves the right, under its continuing product improvement program, to change construction, design, details, specifications, and prices without notice or without incurring any obligation. Meyer Products LLC assumes no responsibility for installations not made in accordance with these instructions.

## Table of Contents

General Information.....	1
Black Iron Parts Lists.....	2-3
Moldboard Parts List.....	4
Standard Operating System Wiring.....	5
Plow Assembly & Adjustments.....	6-7
Hydraulics.....	8-9
Mounting Plow.....	10
Dismounting Plow.....	11
Pre-Delivery Inspection.....	12
Registration.....	12

Please visit our website to find our most updated technical information; including installation instructions, user manuals, parts diagrams, EZ Troubleshooter, and more.

Please see your owner's manual for Pre-Season, Post-Season, and General Maintenance.

[www.meyerproducts.com](http://www.meyerproducts.com)

## **CAUTION** GENERAL INFORMATION

Always disconnect battery prior to installation.

SAFETY PRECAUTIONS should be used when Quik Lift® is in a RAISED position.

LOWER plow to the ground when vehicle is PARKED.

OVERHAUL and SERVICE information is covered on separate instructions.



Note:

1. Connect ground cable to negative side of battery for a solid connection to ground.
2. **CAUTION** Route all cables away from moving engine parts, Manifolds, and sharp sheet metal.
3. For weather protection, coat all connections with Meyer Dielectric Grease Part No. 15632
4. The vehicle must be equipped with a "Heavy Duty Battery" (70 Amp, Hr. Min.), 550 C.C.A. and "Alternator" (60 Amp. Min.) to obtain maximum performance.
5. Follow these instructions explicitly. Warranty does not apply to a Meyer product which has been negligently or improperly assembled or installed.

### Tool List for Plow Assembly

Pliers	9/16" socket
1/2" socket	3/4" box wrench
1/2" box wrench	15/16" box wrench
9/16" box wrench	15/16" deep well socket

### TORQUE CHART FOOT

Bolt Nut Size	Gr. 2 	Gr. 5 	Gr. 8 
1/4-20	4-5		
5/16-18	9-11		
3/8-16	17-20	26-29	
7/16-14		42-46	60-66
1/2-13		64-72	99-100
5/8-11		127-141	179-198

Black Iron Parts List

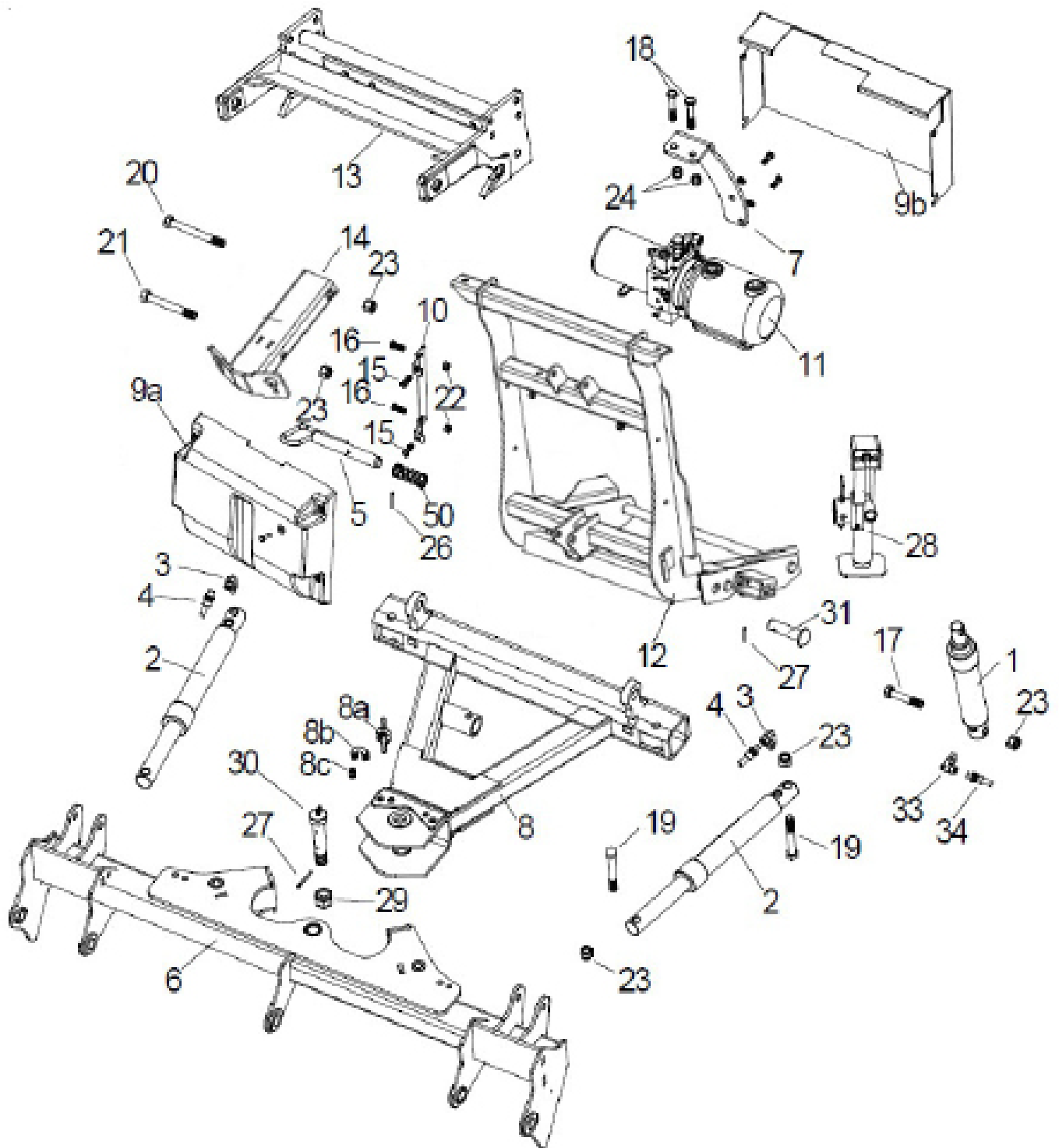

## Black Iron Parts List

Item	Part #	QTY	Description
	41610	1	LP 7.5-9.0 E73 Plus Mount Assy.
1	5818	1	• Lift Ram 1.75 x 8"
	7772	1	• L.H. Ram with Hose & Fittings
2	5887	1	•• Ram (1-1/2" x 10")
3	22866	1	•• SAE Mx3/8 90 Degree Elbow
4	22885	1	•• Hose 1/4 x 54"
	7783	1	• R.H. Ram with Hose & Fittings
2	5887	1	•• Ram (1-1/2" x 10")
3	22866	1	•• SAE Mx3/8 90 Degree Elbow
4	22921	1	•• Hose 1/4 x 38"
5	11859	2	• Blue Handle Pin
6	14214	1	• Pivot Bar Lot Pro
7	14185	1	• E-73 Mounting Bracket
8	14704	1	• A-Frame
8a	21541	2	• Chain 5/16 x 38" Gr. 43
8b	8518001026	2	• U-Bolt 7/16-14
8c	20306	4	• Locknut 7/16-14
9a	14596	1	• Lift Unit Cover Front
9b	14288	1	• Lift Unit Cover Rear
10	14290	2	• Lift Unit Cover Bracket
11	16027	1	• Lift Assembly (Unit only) ***
12	18965	1	• Lift Frame
13	14700	1	• Clevis
14	14439	1	• Lift Arm
15	20027	4	• Bolt H 5/16-18 x 1" Gr. 2
16	20049	4	• Bolt H 3/8-16 x 1" Gr. 2
17	20146	1	• Bolt H 5/8 - 11 x 3-1/4" Gr. 5
18	20101	2	• Bolt H 1/2 - 13 x 3 Gr. 5
19	20150	4	• Bolt H 5/8 - 11 x 4-1/2" Gr. 5
20	22989	1	• Pin 5/8 x 5-3/4"
21	20153	1	• Bolt H 5/8 - 11 x 5-1/2" Gr. 5
22	20305	4	• Locknut 3/8-16
23	20309	6	• Locknut 5/8-11
23a	20152	1	• BOLT H 5/8 11 X 5 G5 ZN
24	20307	2	• Locknut 1/2-13
25	22153	1	• Lockbolt 5/16 x 5/8
26	20406	3	• Cotter Pin 3/16 x 1-1/2"
27	20420	2	• Cotter Pin 1/4 x 2"
28	22022	1	• Crank Stand
29	22274	1	• Slotted Nut 1-8
30	22398	1	• King Bolt 1-8 x 5-1/2"
31	22436	2	• Pin 1 x 3"
32	23039	1	• Plow Side Harness
33	22866	1	• SAE Mx3/8 90 Degree Elbow
34	22884	1	• Hose 1/4 x 33"

Item	Part #	QTY	Description
	41362	1	• Accessory Box
35	23025	1	•• Power Cable
36	7017	4	•• Trip Spring
	23067	1	•• Nite Saber LED
	9917	1	•• Plow Marker Kit
37	8214	2	••• Plow Marker
38	20027	4	••• Bolt H 5/16-18 x 1 Gr. 2
39	20304	4	••• Locknut 5/16-18
40	20352	8	••• Flatwasher 5/16"
41	11844	1	•• Receiver Tube Cap
42	15372	1	•• Starter Solenoid - 12 volt
43	21832	1	••• Split Bushing
44	23047	1	•• Controller
45	23059	1	•• Truck Side Harness (4 Pin)*
	23038	1	•• Truck Side Harness (7 Pin)*
	41302	1	•• Hardware Bag
46	9124	4	••• Eye Bolt
47	20406	3	••• Cotter Pin 3/16 x 1-1/2"
48	22331	1	••• Hex Head Pin 1 x 3-5/16"
49	22375	2	••• Pivot Pin 1 x 8-3/4"
50	814000005	2	• Spring

Parts indented are included in the carton, bag or assembly under which they are indented.

## Moldboard Parts List

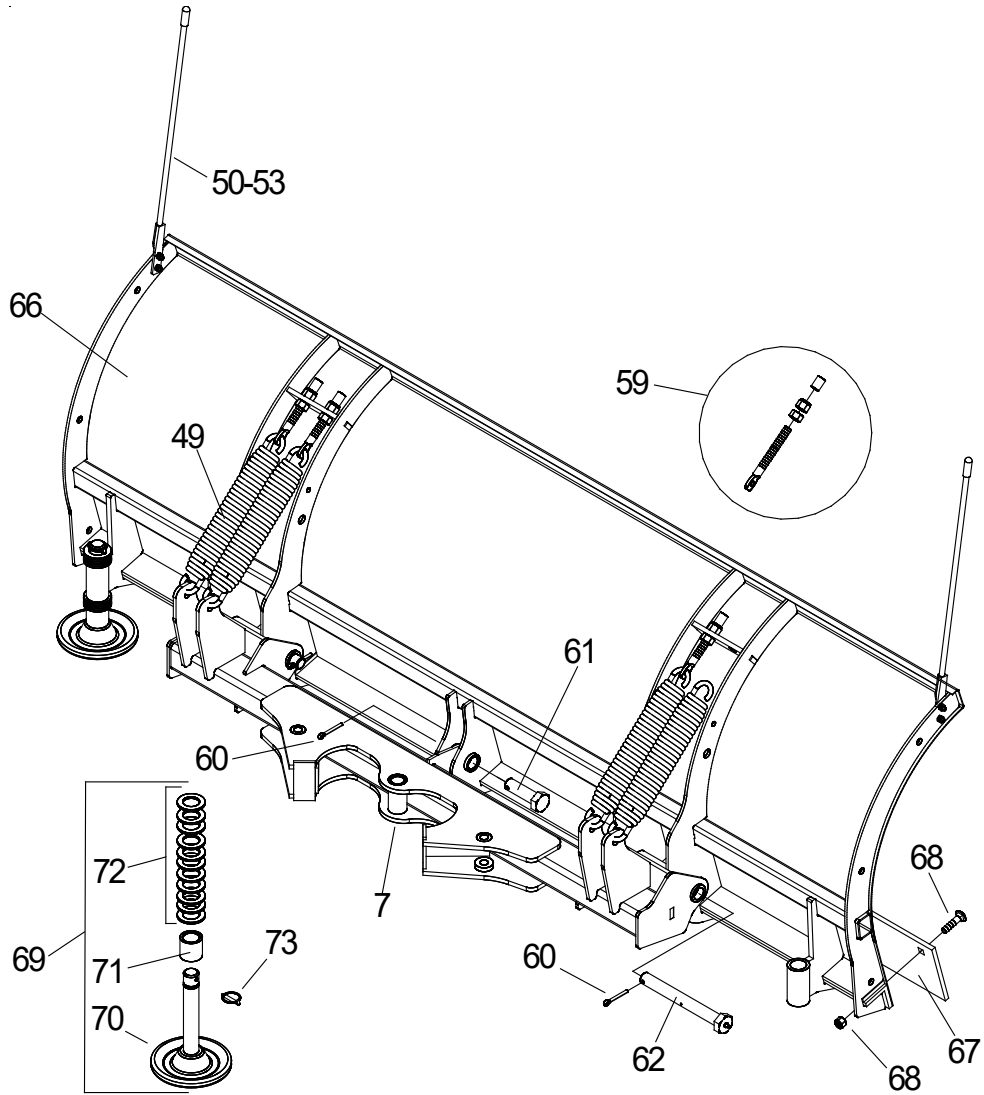

Item	7' 6"	8'	8' 6"	9'	Qty	Description
	79400K	79401K	79402K	79403K		• Moldboard Kit
66	79400	79401	79402	79403	1	• Moldboard Assembly
67	09797	09133	09134	07259	1	•• Cutting Edge
68	08486	N/A	N/A	N/A	1	•• Bolt C 1/2-13 x 1-3/4 & Locknut (Kit of 9 each)
68	N/A	08692	08692	N/A	1	•• Bolt C 1/2-13 x 2 & Locknut (Kit of 10 each)
68	N/A	N/A	N/A	08318	1	•• Bolt C 5/8-11 x 2-1/4 & Locknut (Kit of 12 each)
69	9362	09362	09362	09362	2	•• Mushroom Shoe Casting Assy.
70	12394	12394	12394	12394	1	••• Runner Shoe Casting
71	12449	12449	12449	12449	1	••• Runner Spacer
72	20363	20363	20363	20363	11	••• Flatwasher 1-1/4
73	22083	22083	22083	22083	1	••• Linch Pin
	08109R	08111R	08112R	08113R	1	• Deflector

# Wiring Harnesses & Controller

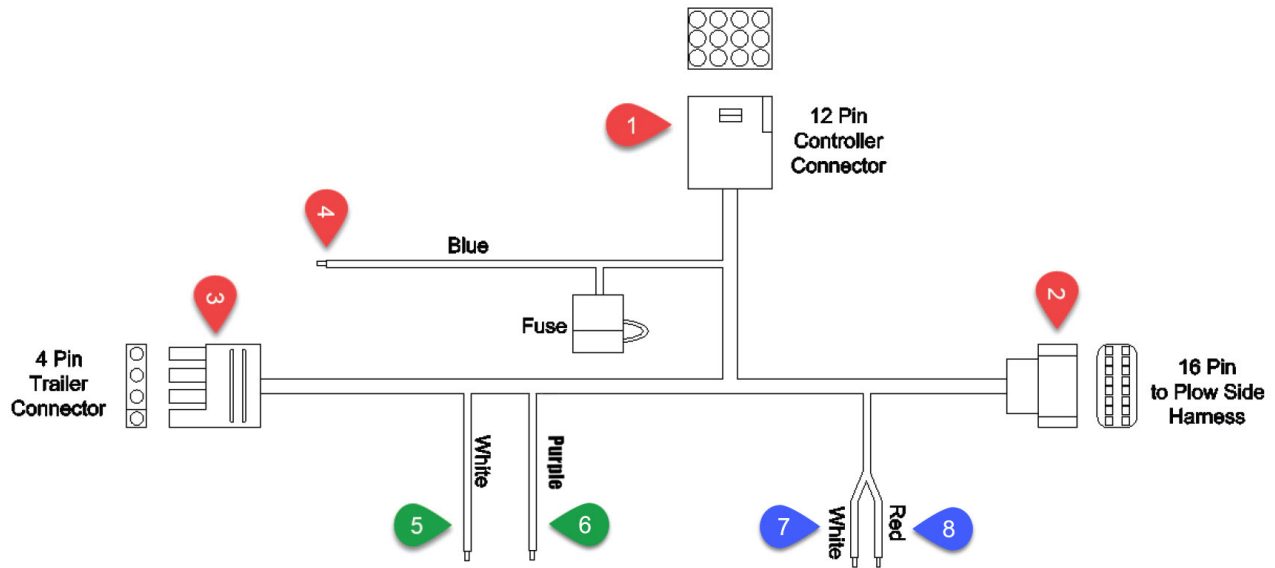

## Vehicle Side Harness

- 1) Route the 12 pin connector into vehicle's cab and plug into controller.
- 2) Route the 16 pin connector to the front of the vehicle and plug into the plow side harness.
- 3) Route the 4 pin connector to rear of vehicle and plug into vehicle's trailer harness using the trailer adapter harness. Use cable ties to ensure the harness is secured to the vehicle's frame.



Trailer Adapter Harness

- 4) The BLUE wire will connect to the vehicle's keyed accessory circuit. This is to ensure the plow turns on and off with the vehicle's ignition.

*The following step is for 2015 & later GM vehicles with an alternator relay...*

- 5) The WHITE wire will connect to 2015 & Later GM vehicles with alternator relay. See Meyer Products Service Bulletin SB252.
- 6) The PURPLE wire will connect to the black /violet wire of 2015 and later models of RAM 2500, 3500, 4500, and 5500 models. See mount instructions for further detail.

*The following two steps are optional and may be enforced by local law which requires your vehicle lights to be off while your plow lights are on and vice versa...*

- 6) Connect the RED to the HIGH beam function.
- 7) Connect the WHITE to the LOW beam function.

## Power Harness

- 1) Route through the vehicle's grille.
- 2) Connect the terminals to the vehicle's battery. Red to Positive and Black to Negative.

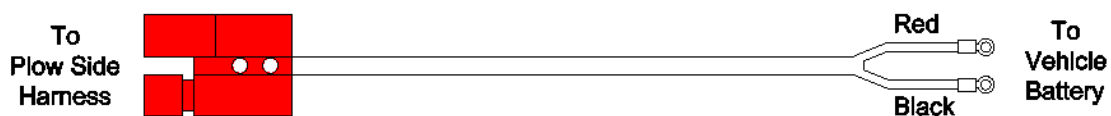

# Plow Assembly & Adjustments

## Adjustable Clevis

The 14700 adjustable clevis is now standard with all Standard Operating System black iron packages. The 14700 Adjustable Clevis cannot be used with any EZ+ Operating System plow model.

The 14700 Clevis offers 3 levels of adjustability for a height difference of +/- 1.5 inches. To use the adjustability feature, mounting the clevis using two sets of applicable holes. Use one of the bottom 3 holes to secure to the clevis to the mount.

- Level 1 = Rows 1 and 3
- Level 2 = Rows 2 and 4
- Level 3 = Rows 3 and 5

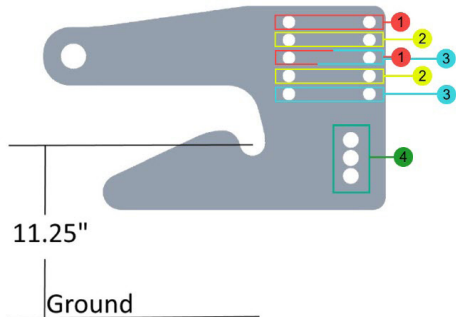

The clevis requires a height of 11.25" off the ground in order for the plow to sit level.

## Pivot Bar

The Pivot Bar will need to be bolted to the A-Frame and Angling Cylinders. Cut any ties that are securing the cylinders to the crate prior to removing black iron from the crate. The Angling Cylinders will already be connected to the Lift Frame. Hardware to attach the Pivot Bar to the Angling Cylinders and A-Frame can be found in the Accessory Box.

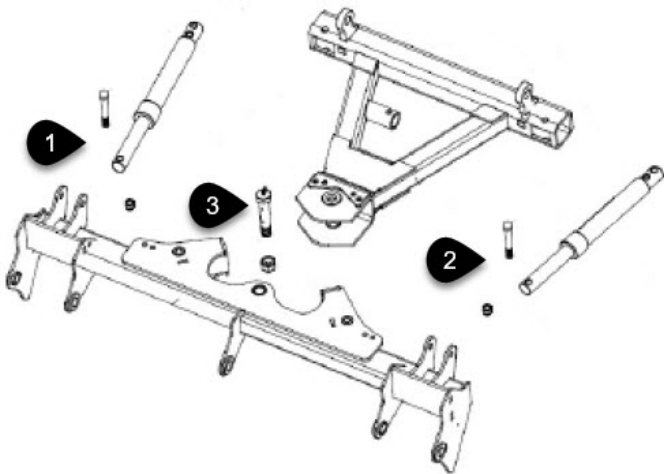

## Nite Saber LED Lights

See separate Nite Saber LED instructions for further information.

Mount the lights as shown below.

Connect both male ends from the snow plow light to the female ends on the Plow Side Harness. Ensure all wiring harnesses are secured against the lift frame.

Check snow plow lights and blinkers to ensure proper operation. If operating in reverse (i.e. driver side blinking instead of passenger side), reverse the harness connections.

Note: All electrical connections should have both ends coated with a dielectric grease (Meyer Part # 15632) prior to final installation. This will ensure a good connection and help in preventing corrosion.

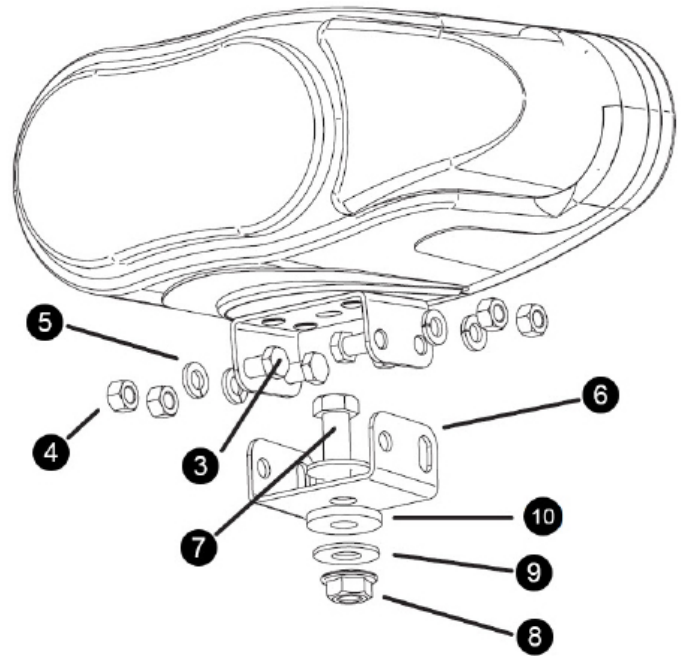

Nite Saber LED Parts List

Item	Part	QTY	Description
-	23067	1	Nite Saber LED Kit
-	23066	1	Passenger Side LED
-	23065	1	Driver Side LED
-	08126	1	Hardware Bag
3	----	8	• Hex Bolt 3/8" x 3/4", SS
4	----	8	• Hex Nut 3/8", SS
5	----	8	• Lock Washer 3/8", SS
6	----	2	• Metal Bracket, Bottom
7	----	2	• Bolt 1/2"- 13 x 1 1/12", SS
8	----	2	• Hex Lock Nut 1/2" - 13, SS
9	----	4	• Flat Washer 1/2", SS
10	----	2	• Neoprene Grommet 1/2"

# Plow Assembly & Adjustments

## Trip Spring Adjustment

Attach Eye Bolts to Moldboard and Trip Springs to Pivot Bar, making certain locknuts are positioned as shown below.

Make certain each Eye Bolt is in a vertical position as shown below so that the Eye Bolt and Trip Spring hinge properly when the Moldboard trips.

Note: Proper tension is attained when the Trip Spring coils just begin to separate and then tightening top locknut four additional turns. Tighten bottom locknut to secure Eye Bolt in position.

Install Eye Bolt Caps over exposed threads.

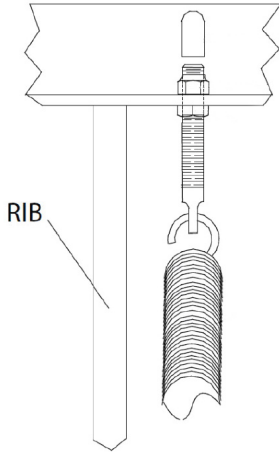

## Plow Markers

Attach Plow Markers to moldboard using 5/16-18 x 1" Bolt, 5/16" Flatwasher, and 5/16-18 Locknut.

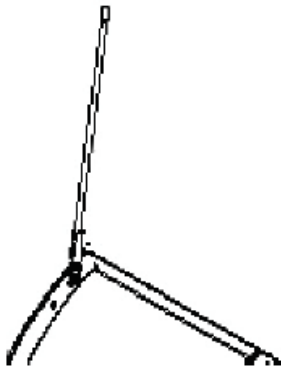

## Lift Chains

Attach the Lift Chain to the Lift Arm through the two hooks on the lift arm. Adjust the lift chain at the lift arm so that there are 2-3 links of slack. This ensures that the plow blade will lift fully and be able to follow the ground contour while plowing.



## Hydraulic Fluid Level

Top off the unit to the fill line on the reservoir with Meyer M-1 Hydraulic Fluid.

NOTE: Proper fluid level is to the fill line on the reservoir for the E73. It must be checked with the lift cylinder fully retracted.



## Drop Speed Adjustment

E73 Drop Speed Adjustment: Loosen jam nut and turn knob clockwise to slow the drop of the plow and counter clockwise to speed the drop of the plow. Tighten jam nut.

Drop Speed Adjustment

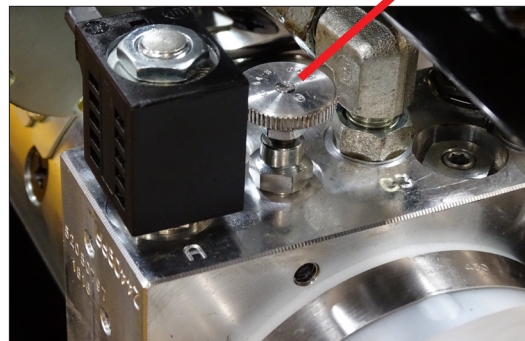



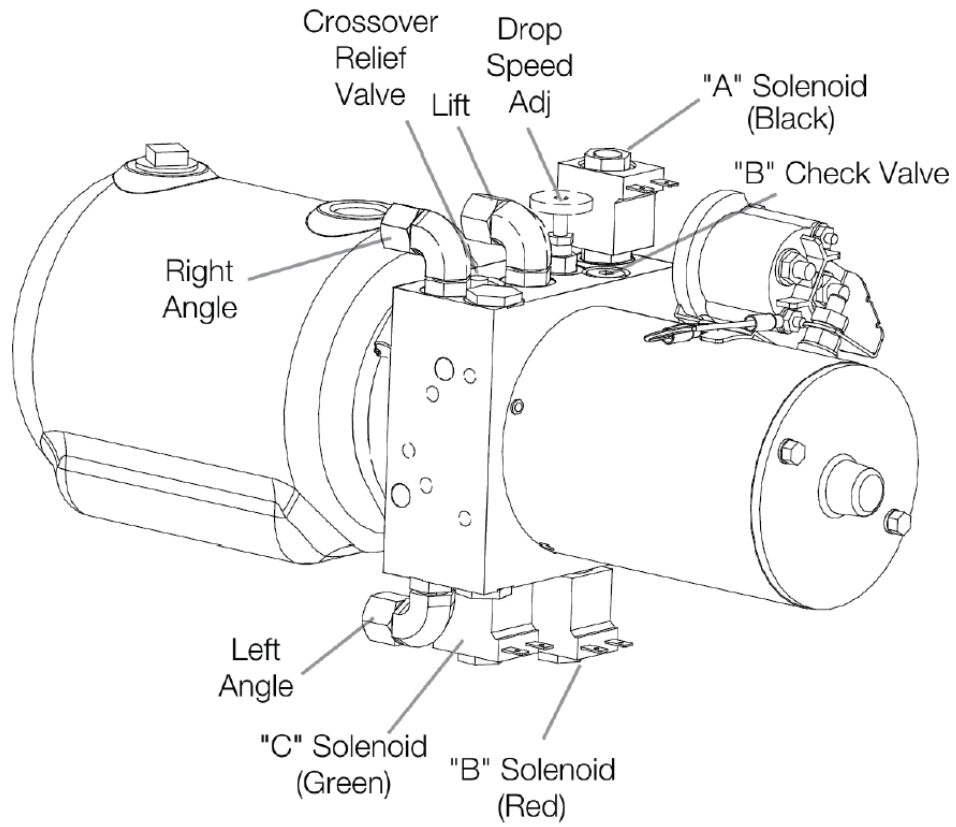

E-73	Raise	Lower	Angle Right	Angle Left
Motor	X		X	X
A Valve		X		
B Valve	X			
C Valve			X	

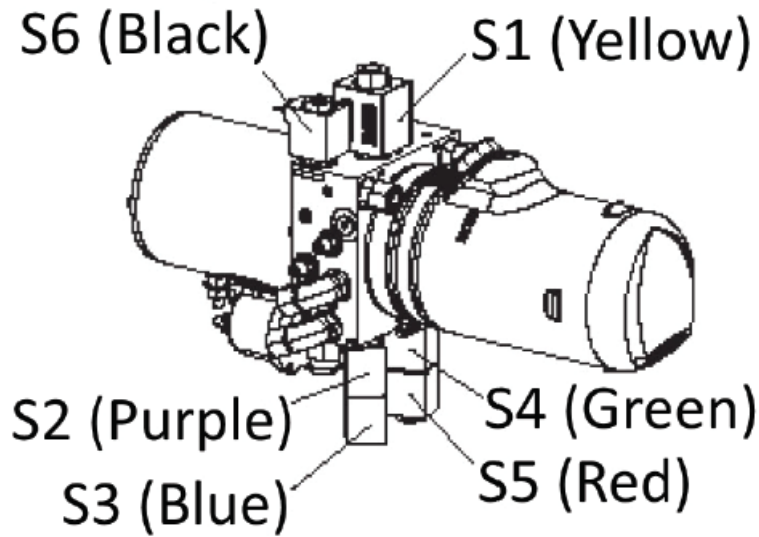

V73	Raise	Lower	Left	Left Extend	Left Retract	Right	Right Extend	Right Retract	Vee	Scoop
Motor	X		X	X	X	X	X	X	X	X
S1		X								
S2				X		X				X
S3			X		X				X	X
S4						X		X	X	
S5			X				X			
S6	X									

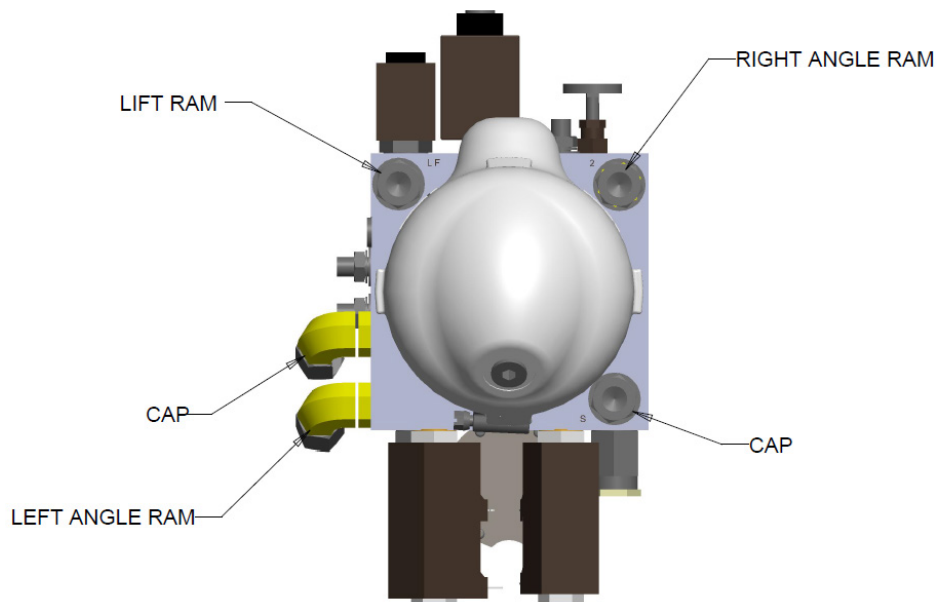

NOTE: 16025 may be used in place of 16027. In order to do so, two of the ports will be capped off while the left and right angling hoses will need to be removed and swapped. Move 22921 to the left angling ram and 22885 to the right angling ram. See the image above for further information.

## Mounting Plow

**NOTE:** Pictures may vary based on model



**A.** Pull vehicle into plow assembly and push plow assembly forward an inch or two.



**B.** Twist handles on both sides to engage spring loaded pins.



**C.** Push back on lift frame until both pins spring through mount on vehicle.



**D.** Adjust crankstand until it is no longer in contact with the ground.

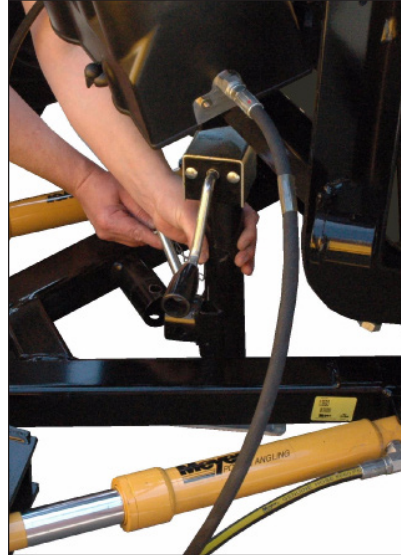

**E.** Remove crankstand from a-frame.



**F.** Attach crankstand to lift frame.



**G.** Remove weather cover on both ends and connect both electrical plugs.

## Dismounting Plow



**A.** Press down button until float light turns blue.

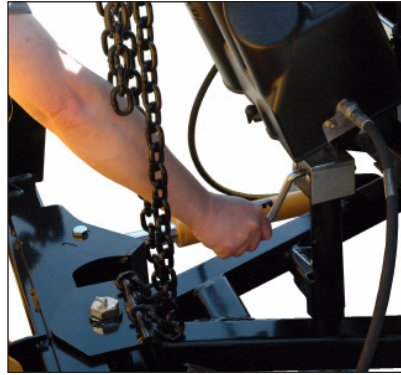

**E.** Adjust crankstand until the crankstand comes in contact with the ground and then turn 1 to 2 revolutions.

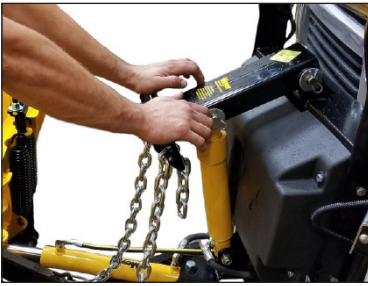

**B.** Push lift arm down until there is slack in the chain.



**C.** Remove crankstand from lift frame.



**D.** Attach crankstand to a-frame



**G.** Disconnect both electrical plugs and install weather cover on both ends.

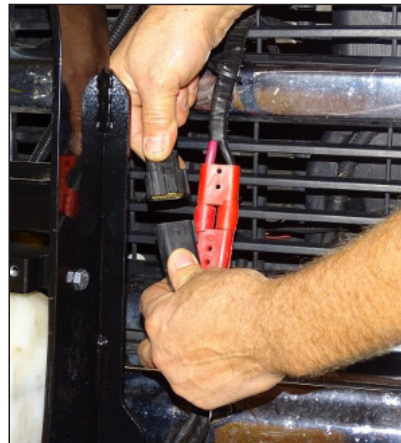

**F.** While slightly pushing the lift frame towards vehicle pull handles on either side to disengage pins then twist until the leg locks the pin in the open position.



**H.** Back vehicle away from plow assembly.

## PRE-DELIVERY INSPECTION

Vehicle Make: \_\_\_\_\_

Vehicle Model: \_\_\_\_\_

Vehicle Year: \_\_\_\_\_

Vehicle VIN#: \_\_\_\_\_

Vehicle FGAWR: \_\_\_\_\_

Installing Company: \_\_\_\_\_

Hydraulic Serial Number: \_\_\_\_\_

Moldboard Serial Number: \_\_\_\_\_

- All bolts torqued to specification
- Suspension interference
- Clevis height in inches \_\_\_\_\_
- Trip springs adjusted
- Lift Chain Adjusted
- Check for hydraulic fluid leaks
- Hydraulic fluid Level
- Dielectric grease applied to ALL electrical connection
- All wires secured
- Plow Stops Adjusted (plow cannot bump hyd. unit)
- Controller Operation

Clevis height

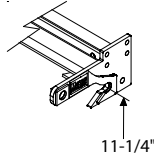

- Plow Operation Up
- Plow Operation Left
- Plow Operation Right
- Plow Operation Down
- Plow Light Blinker Left & Right Operation
- Plow Light Low & High Beam Operation
- Plow Lights Adjusted
- Plow Mount/Dismount reviewed with Customer
- Plow Operation reviewed with Customer
- Warranty/Registration/Owners Manual
- Reviewed with Customer

Notes:

Inspected By: \_\_\_\_\_ W.O.#: \_\_\_\_\_ Date: \_\_\_\_\_

Customer Signature: \_\_\_\_\_

### Serial Number Decal Locations

Moldboard serial tags are attached to the back of the moldboard, the outer rib of the moldboard, and on the black iron near the hydraulic unit.

Note: SV3 Plows use the same serial number for both hydraulic and moldboard.



### Registration

You must register your plow online to be eligible for the 5 year warranty. Please visit...

[www.meyerproducts.com/product-registration](http://www.meyerproducts.com/product-registration)

Please note your registration ID for future reference.

Registration ID \_\_\_\_\_