

PARTS & INSTALLATION INSTRUCTIONS





MDII™ and EZ MOUNT PLUS™

SNOW PLOW MOUNTING 17199

2019 & LATER GMC 4500/5500 4 X 4



End user must be given this instruction sheet prior to delivery of Snow Plow.

SAFETY DEFINITIONS



	This is the safety alert symbol. It is used to alert you to potential personal injury hazards. Obey all safety messages that follow this symbol to avoid possible injury or death.
	DANGER Indicates an imminently hazardous situation which, if not avoided, will result in death or serious injury.
	WARNING Indicates a potentially hazardous situation which, if not avoided, could result in death or serious injury.
	CAUTION Indicates an potentially hazardous situation which, if not avoided, may result in minor or moderate injury.
	CAUTION used without the safety alert symbol indicates a potentially hazardous situation which, if not avoided, will result in property damage.

IMPORTANT NOTICE

In conjunction with FMVSS (Federal Motor Vehicle Safety Standards) and OEM (Original Equipment Manufacturer) guidelines, Meyer Products has designed this plow package with the following guidelines:

	Installation of a snowplow may effect your new vehicle warranty. For more information consult your Vehicle Owner's Manual / Vehicle Dealer.
	The vehicle must not be operated when overloaded. In all cases, the loaded vehicle weight, including the entire snowplow system, all aftermarket accessories, driver, passenger, options, nominal fluid levels, and cargo must not exceed the front/rear Gross Axle Weight Rating (GAWR), and total Gross Vehicle Weight Rating (GVWR). These weights ratings are specified on the safety compliance certification label on the driver's side door opening. The use of rear ballast weight may be required to prevent exceeding the front GAWR.

According to the NHTSA (National Highway Traffic Safety Administration) new and untitled vehicles need to be verified by the installer that snowplow and ballast (if needed) do no exceed the front/rear GAWR and total GVWR.

	 Read the Meyer Owner's Manual before operating or servicing a snowplow. FOLLOW THESE INSTRUCTIONS EXPLICITLY.
---	---

GENERAL INFORMATION

	SAFETY PRECAUTIONS should be used when Hydraulic Unit is in OPERATION and plow is in a RAISED position. Lower plow to ground when vehicle is PARKED in case of hydraulic failure.
---	--

Check contents against the parts list to determine all are correct and included, and also to familiarize yourself with them.

	Warranty does not apply to a Meyer product which has been negligently or improperly assembled or installed.
---	---

	CAUTION: To avoid harm to vehicles electrical system always disconnect battery before beginning installation. DO NOT BURN holes or WELD vehicle frame. This may cause frame failure.
---	---

OVERHAUL and SERVICE INFORMATION are covered on separate instructions.

Meyer Products reserves the right, under its continuing product improvement program, to change construction or design details, specifications and prices without notice or without incurring any obligation.

PARTS LIST

ITEM	PART NO.	QTY.	DESCRIPTION
	17199	1	MOUNTING CARTON
1	19102	1	REAR BRACE
2	19103	1	LH SIDE MEMBER
3	19104	1	RH SIDE MEMBER
4	08994	1	• HARDWARE BAG
5	20096	8	•• BOLT 1/2-13 x 1-3/4" GR 5
6	20097	8	•• BOLT 1/2-13 x 2" GR 5
7	20307	16	•• LOCKNUT ESNA 1/2-13
8	20309	8	•• LOCKNUT ESNA 5/8-11
9	20144	6	•• BOLT 5/8-11 x 2-3/4" GR 5
10	20141	2	•• BOLT 5/8-11 x 2" GR 5
11	19370	1	UNIVERSAL CLEVIS (PART OF CLF CARTON)



Parts indented are included in the carton, bag or assembly under which they are indented.

IMPORTANT

After first use, retighten all mounting bolt connections to specified torque. All mounting bolt connections to be checked periodically for tightness.

Locknuts are furnished DO NOT tighten bolts and nuts until installation is complete (unless otherwise specified), then be sure to tighten all attaching parts per specified torque chart.

TORQUE CHART FOOT

Bolt Nut Size	Gr. 2 	Gr. 5 	Gr. 8 
1/4 - 20	4 - 5		
5/16 - 18	9 - 11		
3/8 - 16	17 - 20	26 - 29	
7/16 - 14		42 - 46	60 - 66
1/2 - 13		64 - 72	90 - 100
5/8 - 11		127 - 141	179 - 198

NOTE: THIS MOUNTING CARTON CAN BE USED WITH THE MDII OR EZ MOUNT PLUS CLF CARTONS.

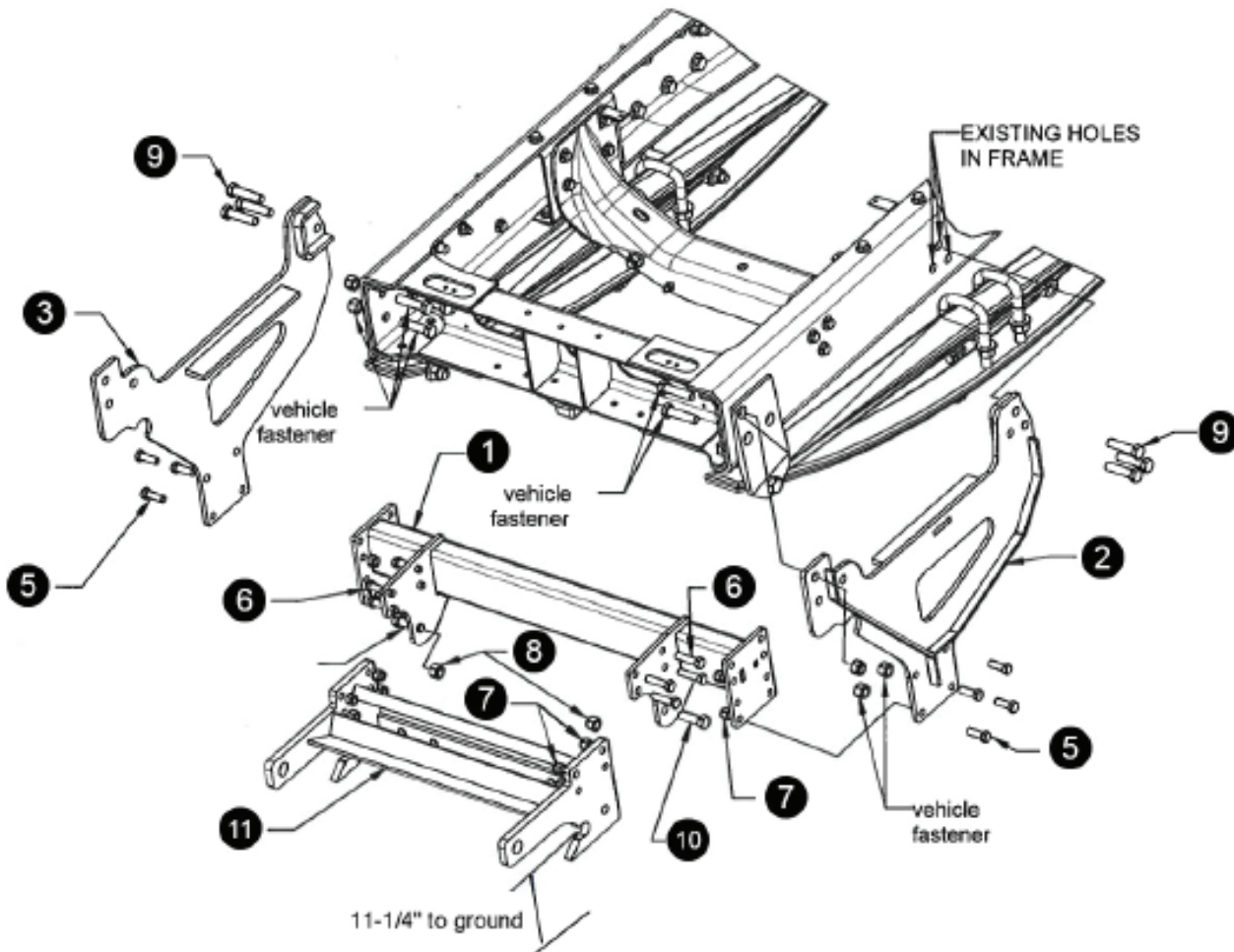

VEHICLE RECOMMENDATIONS



Front end wheel alignment and headlight aim may require re-adjustment after installation of equipment and is the responsibility of the equipment installer. Failure to adjust front wheel alignment may cause premature uneven tire wear. If required, reset to chassis manufacturer's specifications found in the GM Shop Manual.

Rear ballast is determined by weighing a vehicle's front and rear axles and adding weight behind the rear axle until front axle weight is under or equal to the vehicle specific front GAWR while not exceeding the rear GAWR and GVWR.

Vehicle option packages may vary. If in doubt, it is always a good idea to weigh the vehicle to ensure all weight ratings are not exceeded with plow in the raised position.

INSTALLATION INSTRUCTIONS

- A. Remove front bumper. Retain with hardware for reinstallation at the end of procedure.
- B. Remove three of the four vehicle fastener nuts on driver's side that attach the front leaf spring bracket. Retain all hardware, it will be reused.
- C. If the vehicle is equipped with a sway bar, it will need to be removed to allow the mount to be installed. This is applicable to all models.
- D. Assemble LH side member (#) as shown in view. Secure front (3) attachment points to front leaf spring bracket bolts and use nuts to tighten. Fasteners should be snugged up at this time. All fasteners will be tightened at the end of the procedure. Secure rear (3) attachment points using (3) 5/8-11 x 2-3/4" bolts (#) and (3) 5/8-11 locknuts (#). Run bolts through (3) existing holes in the frame.
- E. Repeat steps 2 and 3 for RH side member (#).
- F. Assemble the rear brace (#) between the two side members as shown in view. Secure both sides of rear brace with (4) 1/2-13 x 1-3/4" bolts (#) and (4) 1/2-13 locknuts (#) per side.
- G. Attach clevis (*) to rear brace as shown in view. Secure both sides of clevis with (4) 1/2-13 x 2" bolts (#), (4) 1/2-13 locknuts (#), (1) 5/8-11 x 2" bolt (#), and (1) 5/8-11 locknut (#) per side.
- H. Tighten all fasteners to their proper torque.
- I. Reinstall bumper using original hardware.

Meyer Products assumes no responsibility for installations not made in accordance with these instructions.