

Parts & Installation Instructions

AG (Xpress) & LP (Lot Pro)-Series 7.5 thru 9.0 (08370) Steel Moldboard Box Wings

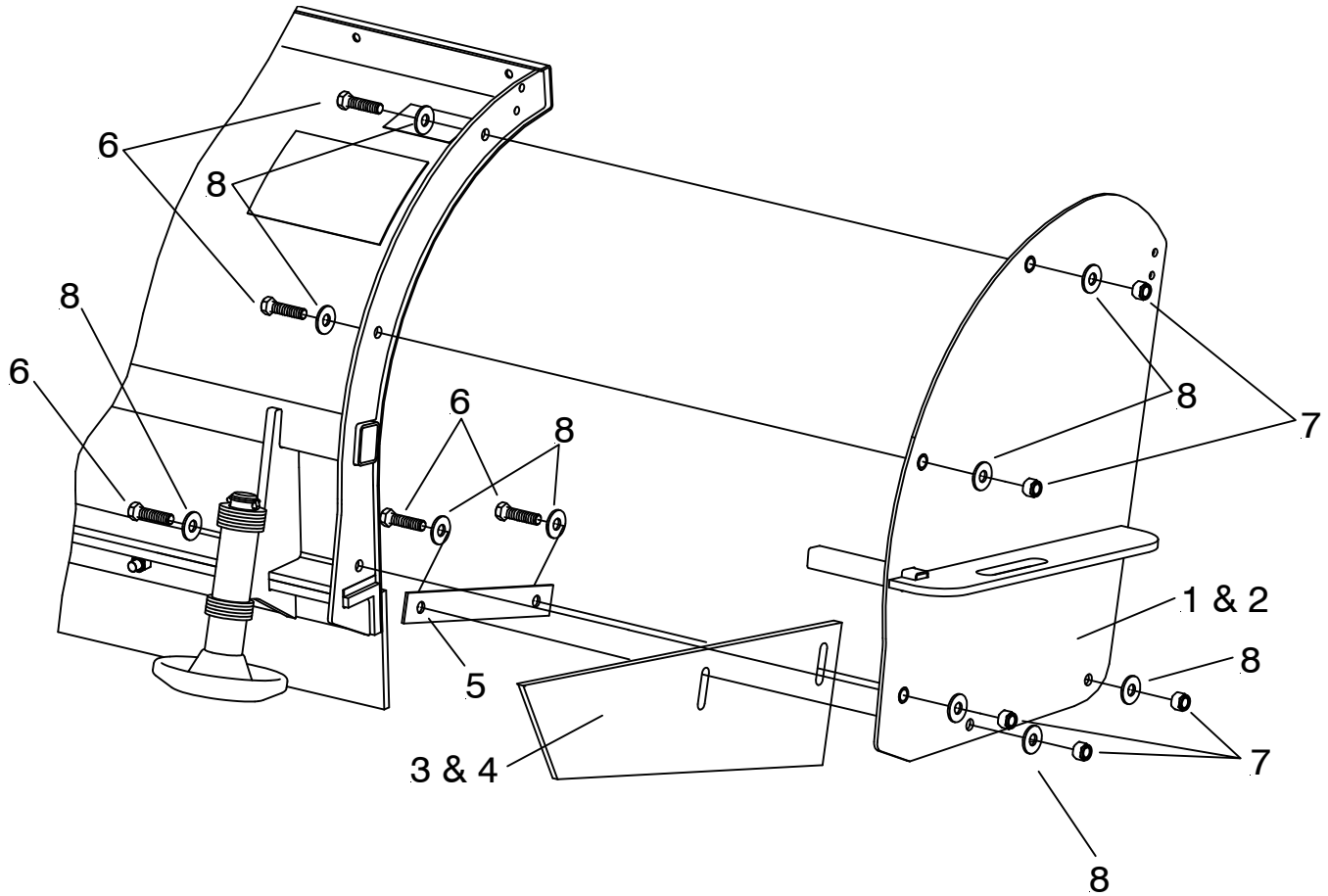

Parts List

Item	Part No.	Qty.	Description
	08370		Moldboard Box Wing Kit
1	10206	1	• RH (Passenger Side) Wing
2	10205	1	• LH (Driver Side) Wing
3	13342	1	• RH (Passenger Side) Wing Rubber Edge
4	13341	1	• LH (Driver Side) Wing Rubber Edge
5	13345	2	• Strap
	08336	1	• Hardware Bag
6	20097	10	• Bolt 1/2-13 x 2" Gr.5
7	20307	10	• Locknut 1/2-13
8	20355	32	• Flawasher 1/2"

Parts indented are included in the assembly under which they are indented.

NOTE: The 08370 Box Wing Kit is not recommended to be used with a rubber or urethane cutting edge.

Meyer Products LLC reserves the right, under its continuing product improvement program, to change construction or design details, specifications and prices without notice or without incurring any obligation.

INSTALLATION INSTRUCTIONS

- A. Slide LH & RH Wing (1 & 2) onto Plow and install using Bolt H 1/2 x 2 (6), 1/2" Flatwashers (8) and 1/2-13 Locknut (7). Wing Pivot should be shimmed with 1/2" washers supplied to keep the wing parallel with the moldboard.
- B. Install LH & RH Wing Rubber Edge (3 & 4) to Wings (1 & 2) using 1/2-13 x 2" Bolt (6), 1/2" Flatwasher (8), Strap (5) and 1/2-13 Locknuts (7). Adjust Wing Rubber Edge (3 & 4) so it will rest flat on the ground when moldboard is on the ground. Tighten Fasteners at this time.

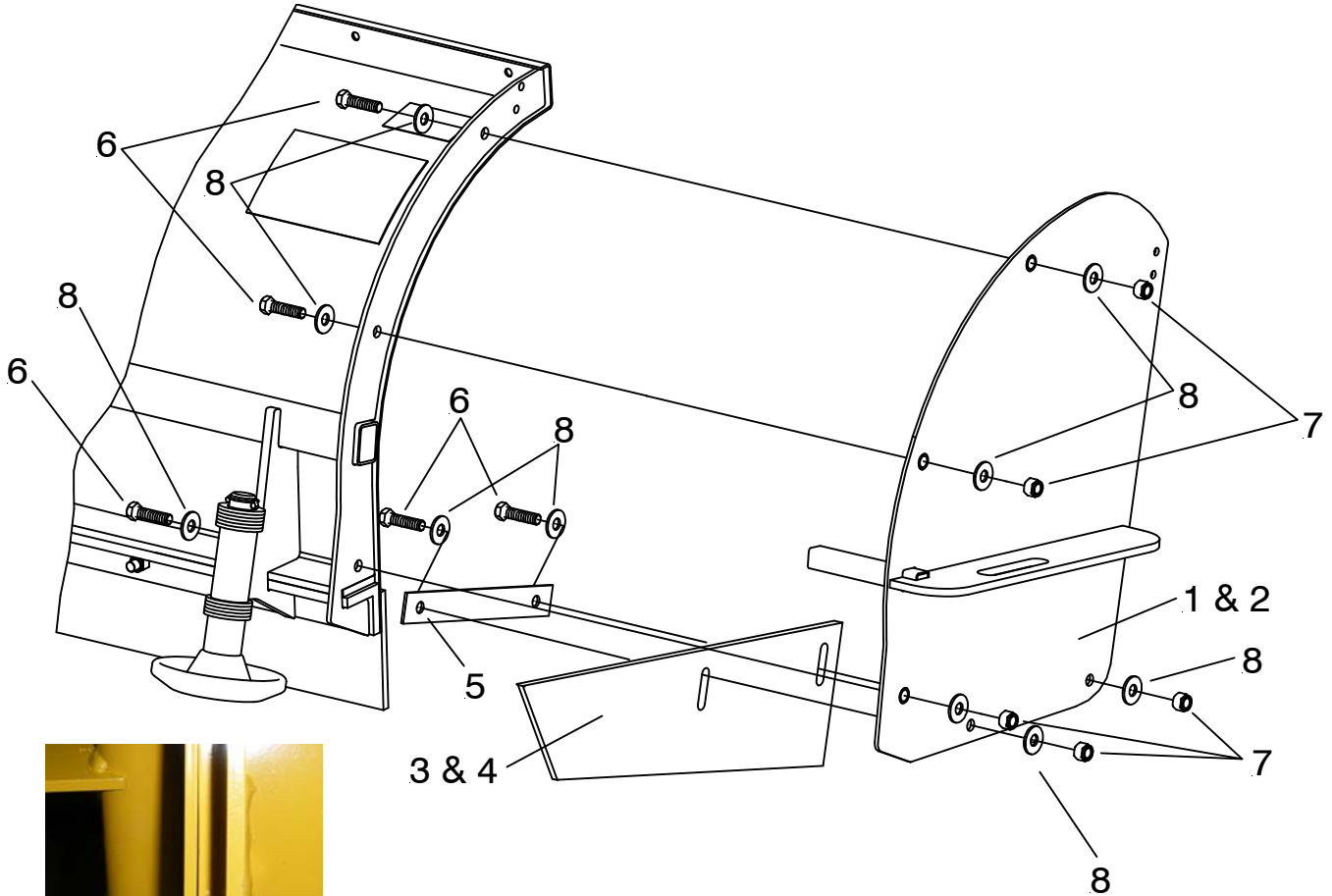

Wing Pivot should be shimmed with 1/2" washers supplied to keep the wing parallel with the moldboard.