

## Parts & Installation Instructions

### Meyer Mini Spreader 36000 and 36006 Plastic Spinner Plate Kit (Part No. 08757)

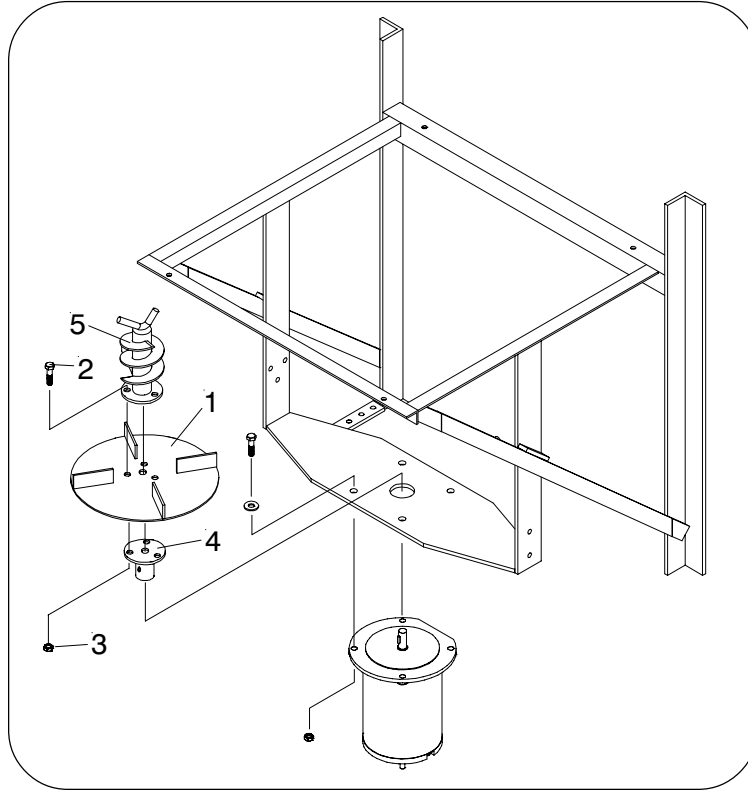

#### Parts List

Item	Part No.	Qty.	Description
	08757	1	Spinner Plate Kit (Plastic)
1	36414	1	• Spinner Plate
	08758	1	• Hardware Bag
2	20005	3	•• Bolt H 1/4-20 x 1" Gr. 2
3	20303	3	•• Locknut 1/4-20

Parts indented are included in the carton, bag or assembly under which they are indented.

### Installation Instructions

- A. Remove the three Bolts (2) and nuts (3) from the Spinner Auger Assembly they will not be reused.
- B. Slide the Auger Weldment (5) up into the hopper and remove old Spinner Plate (1) from the Spinner Hub Weldment (4).
- C. Place new Spinner Plate (1) onto the Spinner Hub Weldment (4) and lower Auger (5) onto Spinner Plate (1). Align mounting holes in Spinner Plate (1), Spinner Hub Weldment (4) and Auger Weldment (5). Attach using 1/4-20 x 1" bolt (2) and 1/4-20 locknut (3). Torque to 25 in. lbs.

**Caution: Over torquing of bolts will distort the Spinner Plate (1).**