

## PARTS & INSTALLATION INSTRUCTIONS

### MEYER SNOW PLOW MOUNTING

### 1992 & LATER FORD F 150 PICK-UP 4x4 VEHICLES

#### IMPORTANT NOTICE

End user must be given this instruction sheet prior to delivery of this Snow Plow.

The equipment you have just purchased should only be used on vehicles equipped with the Manufacturer's Snow Plow Preparation Packages. Snow Plowing without the original Snow Plow Preparation Package may damage your vehicle and the added weight to the equipment may impair the operation and control of the vehicle. Snow Plowing with a vehicle that the manufacturer does not recommend for that purpose may void your new vehicle warranty. If your vehicle is not originally equipped with the Snow Plow Package, additional parts may be necessary before snow plowing. Owners of these vehicles should consult their dealers before purchase or installation of such parts. CAUTION: the installation, on any vehicle, of these parts is not a full substitute for the original equipment Snow Plow Preparation Package.

**Warning:** Lift Arm extends beyond bumper of vehicle. To minimize damage from a front-end collision, Lift Arm should be removed from vehicle when Snow Plow is removed.

#### PARTS LIST

Item	Part No.	Qty.	Description
	17097	1	MOUNTING CARTON
1	11540	1	• Clevis Frame
2	11369	1	• Side Member L.H.
3	11370	1	• Side Member R.H.
4	11536	1	• R.H. Brace
5	11537	1	• L.H. Brace
6	11358	2	• Bar w/Locknut
7	10514	1	• Lift Arm
8	11544	2	• Receiver Tube Cap
	08622	1	• HARDWARE BAG
9	11006	2	•• Hinge Pin
10	10797	2	•• Space
11	14595	2	•• Special Bolt 3/4"
12	14718	1	•• Block Reinforcing
13	20097	2	•• Bolt H 1/2-13 x 2" Gr.5
14	20141	4	•• Bolt H 5/8-11 x 2" Gr.5
15	20144	1	•• Bolt H 5/8-11 x 2-3/4" Gr. 5
16	20146	2	•• Bolt H 5/8-11 x 3-1/4" Gr. 5
17	20149	2	•• Bolt H 5/8-11 x 4" Gr.5
18	20164	2	•• Bolt H 3/4-10 x 2" Gr.5
19	20309	7	•• Locknut Esna 5/8-11
20	20310	1	•• Locknut 3/4-10
21	20353	4	•• Flatwasher 3/8"
22	20357	4	•• Flatwasher 5/8
23	22187	1	•• Bolt H 7/16-14 x 6" Gr.8
24	21984	2	•• Hair Pin Cotter
25	11255	1	LIFT FRAME (Tubular)
11" Sector			
Item	Part No.	Qty.	Description
	16505	1	SECTOR -A-FRAME CARTON
26	12326	1	• Sector
	13612	1	• A- Frame
	07017	3	• Trip Spring
	09916	1	• Marker Kit
	08166	1	• PLOW HARDWARE BAG
27	09119	2	•• Pivot Pin w/Cotter
	11101	2	•• Hinge Pin
28	22083	2	•• Linch Pin
	09122	1	•• King Bolt w/Locknut
	09124	3	•• Eye Bolt w/Locknuts

Parts indented are included in the carton, bag or assembly under which they are indented. When ordering parts, furnish Part No., Name, and Description. Also furnish Vehicle Model and Year. Type of Hydraulic Unit and Moldboard Size.

Meyer Products reserves the right, under its continuing product improvement program, to change construction or design details, specifications and prices without notice or without incurring any obligation.

# GENERAL INFORMATION

**CAUTION:** Always disconnect battery before beginning installation.

**DO NOT BURN** holes or **WELD** vehicle frame. This may cause frame failure.

After first use, retighten all mounting bolt connections to specified torque. All mounting bolt connections to be checked periodically for tightness.

Locknuts are furnished **DO NOT** tighten bolts and nuts until installation is complete (unless otherwise specified), then be sure to tighten all attaching parts per specified torque chart.

**NOTE:** It is important that the Meyer harness, all wires from the Meyer light switch, and all other electrical wires be routed around hot or moving engine parts, and any sharp metal. Protection must be provided to guard against wire damage at these points. All excess or loose wires must be neatly secured using wire ties.

Check contents against the parts list to determine all are correct and included, and also to familiarize yourself with them.

**SAFETY PRECAUTIONS** should be used when **Hydraulic Unit** is in **OPERATION** and plow is in a **RAISED** position. **Lower plow to ground** when vehicle is **PARKED**.

**OVERHAUL** and **SERVICE INFORMATION** are covered on separate instructions.



Follow these instructions explicitly. Warranty does not apply to a Meyer product which has been negligently or improperly assembled or installed.

**WARNING:** This mounting is not designed for installation on Ford Bronco and F-150 vehicles with 1-A stabilizer bar. (Part of handling package option on vehicles with 3550 lb. Front suspension).

Vehicles must have heavy duty front end equipment as recommended by Ford Motor Company for snow plow applications.

**1992 Bronco - 3800 lb. front suspension (674)**  
**1992 & later F-150 - 3800 lb. front suspension (674)**

## TORQUE CHART FOOT LBS.

Bolt Nut Size	Gr. 2 	Gr. 5 	Gr. 8 
1/4 - 20	4 - 5		
5/16 - 18	9 - 11		
3/8 - 16	17 - 20	26 - 29	60 - 66
7/16 - 14		42 - 46	90 - 100
1/2 - 13		64 - 72	179 - 198
5/8 - 11		127 - 141	
3/4 - 10		227 - 251	

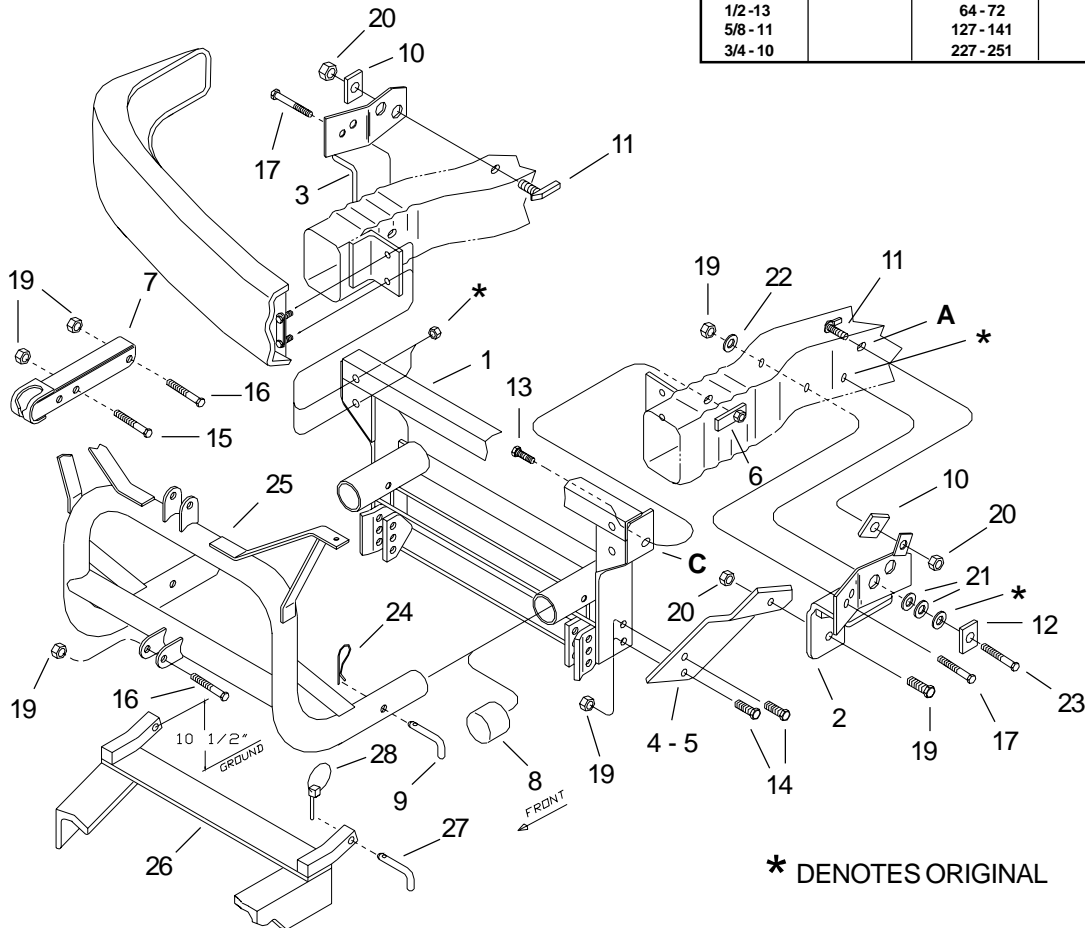

\* DENOTES ORIGINAL

## INSTALLATION INSTRUCTIONS

- A. Remove bumper from vehicle. Retain all hardware (\*); it will be reused.
- B. Insert special 3/4 bolt (11) in slotted hole "A" in vehicle frame to hold side members (2 & 3) in place with 3/4 Locknut (20). Use spacer (10) on passenger side.  
**Do not tighten.**

**Note:** Additional hardware has been provided when installing the driver-side member (2). Remove original steering gear box bolt and replace using 7/16-14 x 6" (23), reinforcing block (12), original vehicle washer (\*), and flatwasher (21) per illustration. **Do not tighten at this time.**

- C. **Make certain side members are flat against bottom of vehicle frame.** Using the small hole "B" in the side members (2 & 3) as a guide, drill hole thru vehicle frame using an 11/16" drill. Attach using 5/8-11 x 4" bolt (17), 5/8 flatwasher (22), and locknut (19). **Hold side members flat against bottom of vehicle frame. Then tighten to proper torque.**

**Note:** Prior to tightening special bolt on passenger side member, make certain spacer (10) is properly aligned over large hole in side member top plate. After the passenger side special bolt has been tightened to its recommended torque, the spacer should be tack welded in place onto the side member. This is to insure the proper installation of the Special bolt into the side of the vehicle frame.

- D. Position clevis frame (1) behind vehicle bumper brackets. Using hole "C" in clevis frame (1) as a template, scribe the hole, then remove the clevis frame and drill a 9/16" hole in vehicle frame.
- E. Reposition clevis frame (1) and attach to vehicle frame using 1/2-13 x 2" bolts (13), and locknut bar (6).

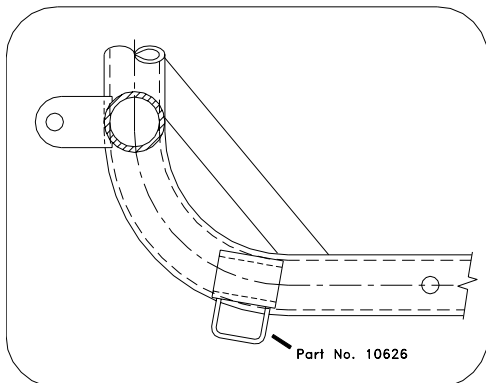
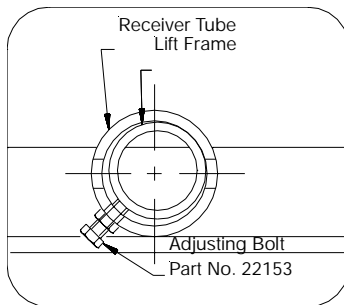

- F. Attach side braces (4 & 5) to side members (2 & 3) using 3/4-10 x 2" bolts (18) and locknuts (20). Attach other end of braces (4 & 5) to clevis frame (1) using 5/8-11 x 2" bolts (14) and locknuts (19).
- G. Reinstall bumper using existing vehicle hardware. (\*)
- H. Tighten all fasteners to their proper torque. Tighten bolts in the same order they were assembled to the vehicle.

**Important Notice:** Prior to installation of the lift frame (25), it will be necessary to identify the lift frame being installed. Current production lift frames have additional stops (Part No. 10626) tack welded to the existing stops. (See illustration.) Earlier production lift frames will not have these stops. Depending upon the S.A.F. Carton being installed, additional stops may need to be added or removed.

- I. When installing S.A.F. Carton 16505, lift frame should have the additional stops Part No. 10626).

**Note:** Before installing lift frame tubing to clevis frame, liberally coat ends of lift frame with chassis grease / anti-seize lubricant.

- J. Install Lift Frame (25) into the tubes on the clevis frame. Turn adjusting bolts in until contact is made with lift frame.

**Caution:** Do not over tighten adjustment bolts. Adjust bolts for minimum clearance between lift frame and receiver tubes while still allowing for ease of lift frame removal. See illustration. Secure lift frame (25) to clevis frame (1) using hinge Pins (9) and hair pin cotters (24).

- K. Attach lift arm (7) to lift frame (25) using 5/8-11 x 3-1/4" bolt (16) and locknut (19). Mount Hydraulic unit to lift frame using 5/8-11 x 3-1/4" bolt (16) and locknut (19), and to lift arm (7) using 5/8-11 x 2-3/4" bolt (15) and locknut (19). **(SEE WARNING)**

- L. Install hydraulic system and snow plow lights per separate instructions.

- M. Pre-Assemble Moldboard Assembly, A-Frame (26), Sector, ect., per separate instructions.

- N. Attach the A-Frame chain to the Lift Arm (7) allowing sufficient slack to enable the Moldboard to follow ground contour while plowing.

**Note:** When the lift frame module (25) is removed from the vehicle, the insides of the clevis frame (1) receiver tubes and outside ends of the lift frame should be coated with chassis grease/anti-seize lubricant and the protective receiver tube caps (8) install over the clevis frame receiver tubes.

Meyer Products assumes no responsibility for installations not made in accordance with these instructions.