



PARTS & INSTALLATION INSTRUCTIONS V-70 ELECTRO-LIFT® UNIT

PARTS LIST

ITEM	V-70	QTY	DESCRIPTION
	15092	1	Lift Assembly (Unit Only) 12V
1	15096	1	• Motor - 12 Volt (2 Terminal)
2	15097	1	• Pump Assembly
3	15083	4	• Allen Head Screw 1/4-20 x 3"
4	15101	1	• Pump Filter Assy.
5	15103	1	• Reservoir
6	15104	1	• Drain Plug
7	15106	5	• Self Tapping Screw 12-24 x 3/8"
8	15108	1	• Fill Plug 3/4-14 NPT
9	15107	1	• Reservoir Breather
10	15099	1	• Oil Tube
11	15100	1	• Oil Tube
12	15095	1	• Base Assembly
13	15121	1	• Adjustable Relief Valve
14	15082	1	• Seal Kit (All Seals)
15	15105	1	• Valve Assembly (12V)
16	15079	1	•• Coil (12V) "S1"
17	15118	5	•• Coil (12V) "S2", "S3", "S5", "S6" & "S7"
18	15112	1	•• "S1" Cartridge Valve
19	15111	3	•• "S2", "S3", "S7" Cartridge Valve
20	15117	2	•• "S5" & "S6" Cartridge Valve
21	15113	1	•• Kit Needle Valve (Lower Adj.)
22	15129	1	•• Kit Dual PO Check Valve
23	15128	1	•• Kit Check Valve Assembly
24	15115	2	•• Kit Relief Valve Assy. 3000 p.s.i.
25	15116	2	•• Kit Relief Valve Assy. 2900 p.s.i.
26	15098	4	• Allen Head Screw 1/4-20 x 3-1/2"

Parts indented are included in assembly under which they are indented.

Meyer Products LLC
18513 Euclid Ave. • Cleveland, Ohio 44112-1084
Phone 486-1313 (Area Code 216)
www.meyerproducts.com • email info@meyerproducts.com



Meyer Products LLC
6 Angell Lane • Damariscotta, ME 04543-4507
Phone 563-2227 (Area Code 207)
www.meyerproducts.com • email info@meyerproducts.com

V-70 PARTS BREAKDOWN

COIL COLOR CODE

- S1 - Red wire
- S2 - Black wire
- S3 - Green wire
- S5 - Yellow wire
- S6 - Blue w/White stripe
- S7 - Purple wire
- Ground Wire each Coil**
- Black w/white stripe**

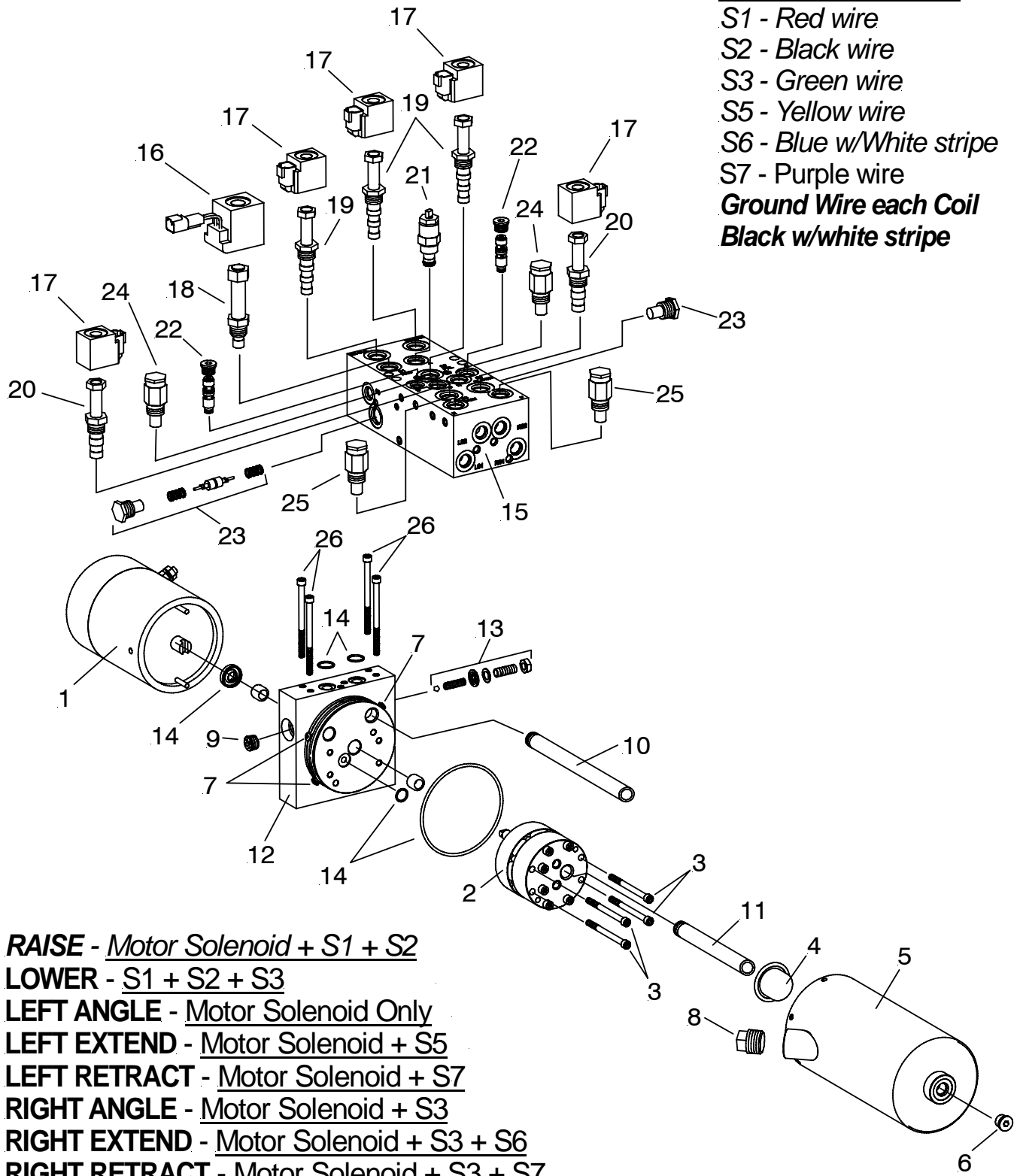

- RAISE - Motor Solenoid + S1 + S2**
- LOWER - S1 + S2 + S3**
- LEFT ANGLE - Motor Solenoid Only**
- LEFT EXTEND - Motor Solenoid + S5**
- LEFT RETRACT - Motor Solenoid + S7**
- RIGHT ANGLE - Motor Solenoid + S3**
- RIGHT EXTEND - Motor Solenoid + S3 + S6**
- RIGHT RETRACT - Motor Solenoid + S3 + S7**
- SCOOP - Motor Solenoid + S2 + S3 + S5 + S6 + S7**
- VEE - Motor Solenoid + S2 + S3 + S7**

GENERAL INFORMATION

Before the Meyer Electro-Lift® unit is disassembled for repairs, make certain that all the maintenance procedures have been checked; refer to Owner's Manual. When the unit is to be overhauled, Seal Kit Part No. 15082 is required. This Kit contains all necessary Seals for rebuilding.

These instructions are intended as a guideline for overhaul of an V-70 Electro-Lift® unit.

When ordering parts, furnish Type of Unit, Part No., Name and Description.

More detailed information covering principles of Operation, Troubleshooting, Disassembly and Repair are found in the V-70 Electro-Lift® Service Manual. This is available for a nominal fee from your Meyer Distributor.

DISASSEMBLY AND INSPECTION OF UNIT

NOTE: DO NOT REUSE OLD O-RINGS.

Drain fluid from the unit by removing Fill Plug (8) and Drain Plug (6). Clamp V-70 unit firmly into vise.

1. Remove Cover.
2. Remove the hydraulic side harness from the hydraulic unit. **Note the positioning of the colored wires on the solenoid coil plugs to the coils on the hydraulic unit. The block is engraved with colors.**
3. Remove hose from Valve Block and Lift Ram.
4. To disassemble MOTOR (1) from Base Plate, loosen Motor mounting bolts.
5. To disassemble VALVE BLOCK ASSEMBLY (15) from BASE ASSEMBLY (12), remove Allen Head Screws (26).
6. To disassemble BASE ASSEMBLY (12) from RESERVOIR (5) remove five Allen SELF TAPPING SCREWS (7).

SUBASSEMBLIES - INSPECTION

1. **BASE ASSEMBLY (12) & RESERVOIR (5)**
 - a) Check Base Assembly (12) for cracks and damage.
 - b) Remove and inspect/replace Adjustable Relief Valve (13) (Set to 2000 P.S.I.)
 - c) Check Reservoir (5) for cracks and damage.
2. **MOTOR - Two Terminal (1)**

Note: Complete Motor Assemblies are only available from Meyer Products. The only service part available is the Brush Kit 15854.
3. **PUMP (2)**

DO NOT at any time disassemble this Pump. This will void the warranty.

 - a) Inspect shaft of Pump Assembly. (2)
 - b) Clean Pump Filter Assy. (4)

4. VALVE ASSEMBLY (15)

- a) Clean "S1" Catridge (18) and inspect for damage.
- b) Clean "S2", "S3" & "S7" Valve Catridge (19) and inspect for damage.
- c) Clean "S5 & S6" (20) Catridge and inspect for damage.
- d) Test all Coils for electrical continuity. Nominal Coil resistance is 8.3 ohms.
- e) Remove Pilot Check Valves (22) and Piston Assemblies (23) from Valve Block and inspect the Piston for scratches.
- f) Remove Relief Valve (24 & 25) and inspect for damage.
- g) Remove Needle Valve (21) and inspect for damage.
- h) With parts removed from Valve Block, clean and blow out with air to remove any foreign particles in Block.

5. UNIT REASSEMBLY

- a) Before reassembling, make certain all components and sub-assemblies are clean and free from all dirt and other foreign material. Lubricate all orings with M-1 oil during assembly. Coat all bolt threads with a anti-sieze lubricant prior to reassembly.
- b) Motor mounting bolts must be sealed with Permatex or an all weather type sealant.
- c) **USE NEW SEALS AND M-1 FLUID WHEN REASSEMBLING THE UNIT.**
- d) Proper fluid level is just below the neck of the filler hole. It must be checked with Lift Ram fully retracted.

IMPORTANT: All Hydraulic Rams should be stored with a light coat of grease on chrome ram in the off season to prevent rust.