



PARTS & INSTALLATION INSTRUCTIONS
MDII™ and EZ MOUNT PLUS™
SNOW PLOW MOUNTING 17123
1994-1996 and 1999-2001 W1500
1994-2002 W2500, W3500
DODGE T-300 4x4 MODELS

RECOMMENDED SNOWPLOW PREPARATION PACKAGE AHD
 End user must be given this instruction sheet prior to delivery of this Snow Plow.

SAFETY DEFINITIONS

	This is the safety alert symbol. It is used to alert you to potential personal injury hazards. Obey all safety messages that follow this symbol to avoid possible injury or death.
	DANGER Indicates an imminently hazardous situation which, if not avoided, will result in death or serious injury.
	WARNING Indicates a potentially hazardous situation which, if not avoided, could result in death or serious injury.
	CAUTION Indicates an potentially hazardous situation which, if not avoided, may result in minor or moderate injury.
	CAUTION used without the safety alert symbol indicates a potentially hazardous situation which, if not avoided, will result in property damage.

IMPORTANT NOTICE

In conjunction with FMVSS (Federal Motor Vehicle Safety Standards) and OEM (Original Equipment Manufacturer) guidelines, Meyer Products has designed this plow package with the following guidelines:

	Installation of a snowplow may effect your new vehicle warranty. For more information consult your Vehicle Owner's Manual / Vehicle Dealer.
	The vehicle must not be operated when overloaded. In all cases, the loaded vehicle weight, including the entire snowplow system, all aftermarket accessories, driver, passenger, options, nominal fluid levels, and cargo must not exceed the front/rear Gross Axle Weight Rating (GAWR), and total Gross Vehicle Weight Rating (GVWR). These weights ratings are specified on the safety compliance certification label on the driver's side door opening. The use of rear ballast weight may be required to prevent exceeding the front GAWR.

According to the NHTSA (National Highway Traffic Safety Administration) new and untitled vehicles need to be verified by the installer that snowplow and ballast (if needed) do no exceed the front/rear GAWR and total GVWR.

	Read the Meyer Owner's Manual before operating or servicing a snowplow. FOLLOW THESE INSTRUCTIONS EXPLICITLY.
--	--

GENERAL INFORMATION

	SAFETY PRECAUTIONS should be used when Hydraulic Unit is in OPERATION and plow is in a RAISED position. Lower plow to ground when vehicle is PARKED in case of hydraulic failure.
--	---

Check contents against the parts list to determine all are correct and included, and also to familiarize yourself with them.

	Warranty does not apply to a Meyer or Diamond product which has been negligently or improperly assembled or installed.
--	--

	CAUTION: To avoid harm to vehicles electrical system always disconnect battery before beginning installation. DO NOT BURN holes or WELD vehicle frame. This may cause frame failure.
--	---

OVERHAUL and SERVICE INFORMATION are covered on separate instructions.

Meyer Products and Diamond Equipment reserves the right, under its continuing product improvement program, to change construction or design details, specifications and prices without notice or without incurring any obligation.

Meyer Products Inc.
 18513 Euclid Ave. • Cleveland, Ohio 44112-1084
 Phone 486-1313 (Area Code 216)
 www.meyerproducts.com • email info@meyerproducts.com

Diamond Equipment
 6 Angell Lane • Damariscotta, ME 04543-4507
 Phone 563-2227 (Area Code 207)
 www.diamondplow.com • email info@diamondplow.com



PARTS LIST

ITEM	PART NO.	QTY.	DESCRIPTION
	17123	1	MOUNTING CARTON
1	11848	1	• Rear Brace Weldment
2	11847	1	• Hanger Weldment
3	11483	1	• L.H. Side Member
4	11484	1	• R.H. Side Member
	08737	1	• HARDWARE BAG
5	14595	2	•• Special Bolt 3/4"
6	20075	6	•• Bolt 7/16-14 x 2" Gr. 5
7	20096	8	•• Bolt H 1/2-13 x 1-3/4" Gr. 5
8	20139	2	•• Bolt H 5/8-11 x 1-1/2" Gr. 5
9	20141	6	•• Bolt H 5/8-11 x 2" Gr. 5
10	20165	4	•• Bolt H 3/4-10 x 2-1/4" Gr. 5
11	20174	2	•• Bolt H 3/4-10 x 5" Gr. 5
12	20306	6	•• Locknut ESNA 7/16-14
13	20307	8	•• Locknut ESNA 1/2-13
14	20309	6	•• Locknut ESNA 5/8-11
15	20310	8	•• Locknut ESNA 3/4-10
16	20354	12	•• Flatwasher 7/16"
17	20355	16	•• Flatwasher 1/2"
18	20357	4	•• Flatwasher 5/8"
19	20359	16	•• Flatwasher 3/4"
20	22134	2	•• Special Washer 5/8"
21	22135	2	•• Handle Nut
22	11139	4	•• Washer Plate 7/16"
*	19370	1	Clevis (Part of PLUS CLF Carton)
**	11770	1	Clevis (Part of MDII CLF Carton)

IMPORTANT

After first use, retighten all mounting bolt connections to specified torque. All mounting bolt connections to be checked periodically for tightness.

Locknuts are furnished **DO NOT** tighten bolts and nuts until installation is complete (unless otherwise specified), then be sure to tighten all attaching parts per specified torque chart.

TORQUE CHART FOOT

Bolt Nut Size	Gr. 2	Gr. 5	Gr. 8
1/4 - 20	4 - 5		
5/16 - 18	9 - 11		
3/8 - 16	17 - 20	26 - 29	
7/16 - 14		42 - 46	60 - 66
1/2 - 13		64 - 72	90 - 100
5/8 - 11		127 - 141	179 - 198

NOTE:

THIS MOUNTING CARTON CAN BE USED WITH THE MDII OR EZ MOUNT PLUS CLF CARTONS.

SECTOR A-FRAME CARTONS

11" SECTOR		15" SECTOR			
1994 - 1996 W1500		1999 - 2001 W1500			
1994 - 2002 W2500-W3500					
PART NO.	QTY.	PART NO.	QTY.	PART NO.	QTY.
16515	1	16520	1	16516	1
DIAMOND					
		81504	1	Common Attachment	
		81026	1	Push Frame	

Parts indented are included in the carton, bag or assembly under which they are indented.

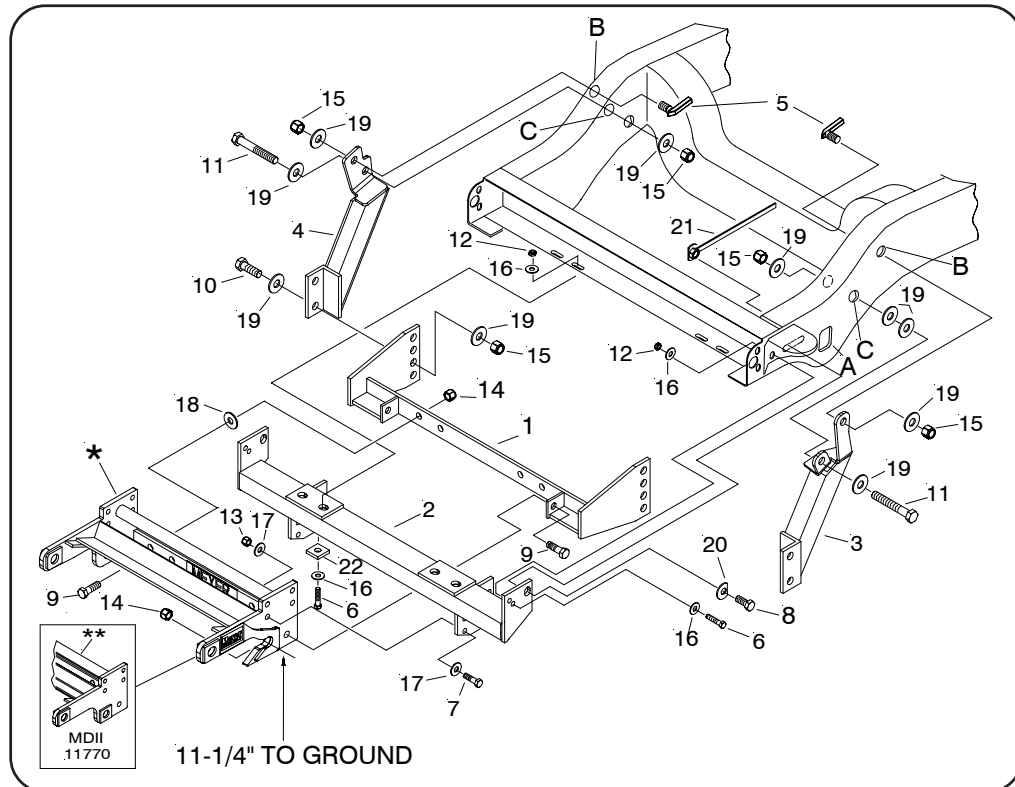

⚠ WARNING

- A ballast weight may be required to prevent front GAWR overloading. If required, ballast must be securely attached at least 24 inches behind the rear axle.

⚠ WARNING

- Front end wheel alignment and headlight aim may require readjustment after installation of equipment, and is the responsibility of the equipment installer. Failure to adjust front wheel alignment may cause premature uneven tire wear. If required, reset to chassis manufacturer's specifications found in the Dodge Shop Manual.

Rear ballast is determined by weighing a vehicle's front and rear axles and adding weight behind the rear axle until front axle weight is under or equal to the vehicle specific front GAWR while not exceeding the rear GAWR and GVWR.

Vehicle option packages may vary. If in doubt, it is always a good idea to weigh the vehicle to ensure all weight ratings are not exceeded with plow in the raised position.

INSTALLATION INSTRUCTIONS

- A. Remove rear bumper support bracket bolt from vehicle frame. Retain all hardware They will not be reused.
- B. Attach Hanger Weldment (2) to vehicle frame at rear bumper support bracket using 7/16-14 x 2" bolts (6), flatwashers (16), Washer Plate (22) and locknuts (12); and at rear slot in vehicle frame using 5/8-11 x 1-1/2" bolts (8), special flatwashers (20), and handle nut (21) per illustration. **Note: Snug all bolts during installation, do not tighten at this time.**

Note: It may be necessary to loosen the outer bumper support brackets to insert handle nut through rectangular hole in side of vehicle frame hole "A". Attach hanger weld (1) to the bottom flange on front vehicle cross-member using 7/16-14 x 2" bolts (6), flatwashers (16), and locknuts (12).

- C. If the vehicle is a 1500 model, attach the Universal Clevis (*) to the upper four holes on the side plates of Hanger Weldment (2). If the vehicle is a 2500 or 3500 model, attach the Universal Clevis (*) to the lower four holes on the side plates of Hanger Weldment (2). Attach using 1/2-13 x 1-3/4" bolts (7), flatwashers (17), and Locknuts (13).

Note: Before snugging bolts in this step be sure the Clevis Frame (*) is level with the ground and pushed back as far under the vehicle as possible.

- D. Attach Rear Brace Weldment (1) to the rear of the Universal Clevis (*) using six 5/8-11 x 2" bolts (9) and locknuts (14) per illustration.

Note: Flatwashers (18) should be sandwiched the between the Universal Clevis (*) and the Rear Brace Weldment (1) on the four rear holes

- E. If the vehicle is a 1500 model, attach the LH & RH Side Members (3&4) to the lower two holes in the Rear Brace Weldment (1). If the vehicle is a 2500 or 3500 model, attach the LH & RH Side Members (3&4) to the upper two holes in the Rear Brace Weldment (1). Attach using 3/4-10 x 2-1/4" bolts (10), flatwashers (19), and locknuts (15).

Note: Depending on the vehicle's manufacture date, holes may already be in vehicle frame for attaching side-members (3&4). If so, skip paragraph "F".

- F. Temporarily raise side members (3&4) until they meet the vehicle frame. While holding them tight against underside of vehicle frame and using the holes in side members as a template, scribe hole location for holes to be drilled in vehicle frame. Lower Side Members (3&4). NOTE: For ease in drilling holes, remove both front tires and jack vehicle body upward to allow clearance of strut on driver's side. Drill a 13/16" hole "C" and a 1" hole "B" (passenger side) in vehicle frame per illustration. "B" and "C" holes to mount side member (3) (drivers side) are already located in the vehicle frame. Holes may require re-sizing (Reaming) for assembly of attachment bolts.

- G. Attach Side members (3&4) at holes "C" using 3/4-10 x 5" bolts (11), flatwashers (19), and locknuts (15). Attach at hole "B" using 3/4" special bolts (5), flatwasher (19), and locknut (15) per illustration. **Note:** Due to vehicle frame variances it may be necessary to use the two spacer washers (19) at driver side hole "C". See illustration.

Note: Before tightening the fasteners, the Clevis Frame (*) should be level with the ground and pushed back as far under the vehicle as possible.

- H. Tighten all fasteners to their proper torque. Tighten bolts in the same order they were assembled to the vehicle.

IMPORTANT: When installation is complete and all bolts have been torqued, it will be necessary to cut off the excess length of the handle on the handle nut (21).

- I. Install remaining snowplow hardware per separate instructions.

Meyer Products or Diamond Equipment assumes no responsibility for installations not made in accordance with these instructions.