



**PARTS & INSTALLATION INSTRUCTIONS**  
**EZ MOUNT CLASSIC™**  
**SNOW PLOW MOUNTING 17091**  
**1981 & 1987 GMC and CHEVROLET V SERIES**  
**4x4 MODELS**

End user must be given this instruction sheet prior to delievery of this Snow Plow.

**SAFETY DEFINITIONS**

	This is the safety alert symbol. It is used to alert you to potential personal injury hazards. Obey all safety messages that follow this symbol to avoid possible injury or death.
	<b>DANGER</b> Indicates an imminently hazardous situation which, if not avoided, will result in death or serious injury.
	<b>WARNING</b> Indicates a potentially hazardous situation which, if not avoided, could result in death or serious injury.
	<b>CAUTION</b> Indicates an potentially hazardous situation which, if not avoided, may result in minor or moderate injury.
	<b>CAUTION</b> used without the safety alert symbol indicates a potentially hazardous situation which, if not avoided, will result in property damage.

**IMPORTANT NOTICE**

In conjunction with FMVSS (Federal Motor Vehicle Safety Standards) and OEM (Original Equipment Manufacturer) guidelines, Meyer Products has designed this plow package with the following guidelines:

	Installation of a snowplow may effect your new vehicle warranty. For more information consult your Vehicle Owner's Manual / Vehicle Dealer.
	The vehicle must not be operated when overloaded. In all cases, the loaded vehicle weight, including the entire snowplow system, all aftermarket accessories, driver, passenger, options, nominal fluid levels, and cargo must not exceed the front/rear Gross Axle Weight Rating (GAWR), and total Gross Vehicle Weight Rating (GVWR). These weights ratings are specified on the safety compliance certification label on the driver's side door opening. The use of rear ballast weight may be required to prevent exceeding the front GAWR.

According to the NHTSA (National Highway Traffic Safety Administration) new and untitled vehicles need to be verified by the installer that snowplow and ballast (if needed) do no exceed the front/rear GAWR and total GVWR.

	Read the Meyer Owner's Manual before operating or servicing a snowplow. <b>FOLLOW THESE INSTRUCTIONS EXPLICITLY.</b>
--	--

**GENERAL INFORMATION**

	<b>SAFETY PRECAUTIONS</b> should be used when <b>Hydraulic Unit is in OPERATION</b> and plow is in a <b>RAISED</b> position. <b>Lower plow to ground when vehicle is PARKED in case of hydraulic failure.</b>
--	---

Check contents against the parts list to determine all are correct and included, and also to familiarize yourself with them.

	Warranty does not apply to a Meyer or Diamond product which has been negligently or improperly assembled or installed.
--	--

	<b>CAUTION: To avoid harm to vehicles electrical system always</b> disconnect battery before beginning installation. <b>DO NOT BURN</b> holes or <b>WELD</b> vehicle frame. This may cause frame failure.
--	---

**OVERHAUL and SERVICE INFORMATION** are covered on separate instructions.

Meyer Products and Diamond Equipment reserves the right, under its continuing product improvement program, to change construction or design details, specifications and prices without notice or without incurring any obligation.

Meyer Products Inc.  
18513 Euclid Ave. • Cleveland, Ohio 44112-1084  
Phone 486-1313 (Area Code 216)  
www.meyerproducts.com • email info@meyerproducts.com

Diamond Equipment  
6 Angell Lane • Damariscotta, ME 04543-4507  
Phone 563-2227 (Area Code 207)  
www.diamondplow.com • email info@diamondplow.com



## PARTS LIST

ITEM	PART NO.	QTY.	DESCRIPTION
	17091	1	MOUNTING CARTON
1	11300	1	• Clevis Frame
2	11295	1	• Support Frame
3	10514	1	• Lift Arm
4	11544	2	• Receiver Tube Cap
	08605	1	• HARDWARE BAG
5	11006	2	•• Hinge Pin
6	11305	2	•• Spacer
7	20077	2	•• Bolt H 7/16-14 x 2-1/2" Gr.5
8	20096	8	•• Bolt H 1/2-13 x 1-3/4" Gr.5
9	20144	1	•• Bolt H 5/8-11 x 2-3/4" Gr. 5
10	20146	2	•• Bolt H 5/8-11 x 3-1/4" Gr. 5
11	20306	2	•• Locknut 7/16-14
12	20307	8	•• Locknut Esna 1/2-13
13	20309	3	•• Locknut Esna 5/8-11
14	20354	2	•• Flatwasher 7/16
15	20355	4	•• Flatwasher 1/2"
	21976	2	•• Battery Connectors
16	21984	2	•• Hair Pin Cotter
17	11255	1	LIFT FRAME (Tubular)
<b>11" S.A.F.</b>		<b>15" S.A.F.</b>	
<b>PART NO.</b>		<b>MEYER</b>	
<b>16503</b>		<b>SECTOR A-FRAME CARTON</b>	
		1	USED WITH 1-1/2" x 10" RAMS
		16504	1
		16511	1
			USED WITH 1-1/2" x 10" RAMS

Parts indented are included in the carton, bag or assembly under which they are indented.

## IMPORTANT

After first use, retighten all mounting bolt connections to specified torque. All mounting bolt connections to be checked periodically for tightness.

Locknuts are furnished **DO NOT** tighten bolts and nuts until installation is complete (unless otherwise specified), then be sure to tighten all attaching parts per specified torque chart.

## TORQUE CHART FOOT

Bolt Nut Size	Gr. 2	Gr. 5	Gr. 8
1/4 - 20	4 - 5		
5/16 - 18	9 - 11		
3/8 - 16	17 - 20	26 - 29	
7/16 - 14		42 - 46	60 - 66
1/2 - 13		64 - 72	90 - 100
5/8 - 11		127 - 141	179 - 198

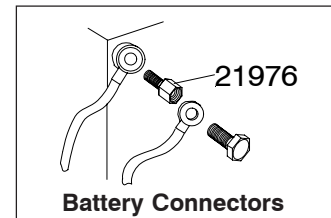

### HYDRAULIC CARTONS

15868 or 15714 1-1/2" x 10" RAMS  
15893 or 15717 1-1/2" x 12" RAMS

**CARE SHOULD BE TAKEN TO INSURE THAT THE S.A.F AND HYDRAULIC CARTONS MATCH.**

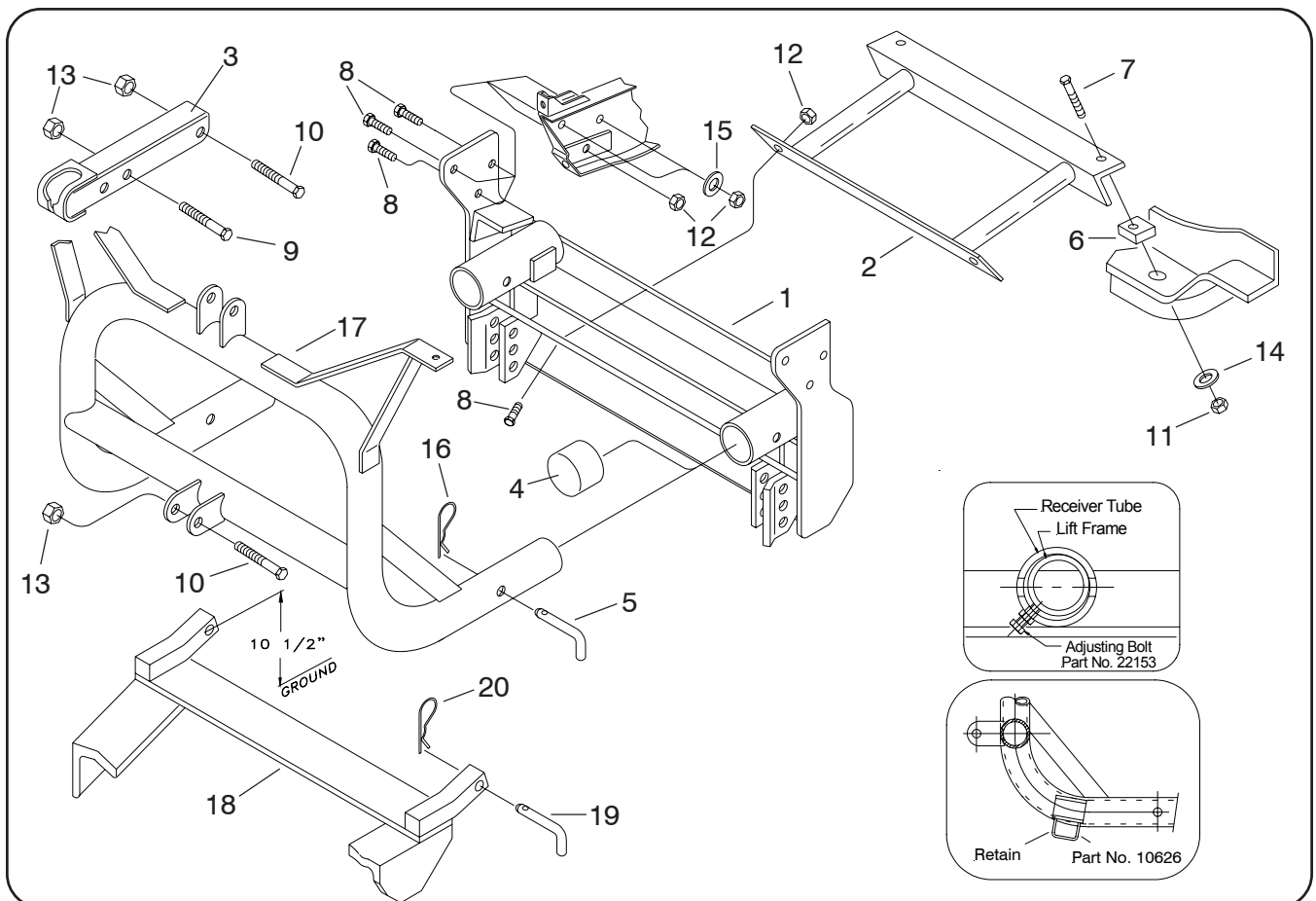

**General Motors recommends that when a snow plow is mounted that only one passenger should accompany the driver. More than one passenger may exceed front gross axle weight ratings.**

**⚠ WARNING**

- A ballast weight may be required to prevent front GAWR overloading. If required, ballast must be securely attached at least 24 inches behind the rear axle.

**⚠ WARNING**

- Front end wheel alignment and headlight aim may require readjustment after installation of equipment, and is the responsibility of the equipment installer. Failure to adjust front wheel alignment may cause premature uneven tire wear. If required, reset to chassis manufacture's specifications found in the GM Shop Manual.

Rear ballast is determined by weighing a vehicle's front and rear axles and adding weight behind the rear axle until front axle weight is under or equal to the vehicle specific front GAWR while not exceeding the rear GAWR and GVWR.

Vehicle option packages may vary. If in doubt, it is always a good idea to weigh the vehicle to ensure all weight ratings are not exceeded with plow in the raised position.

## INSTALLATION INSTRUCTIONS

- Remove tow hooks. Retain all hardware. **The tow hooks will not be reinstalled.**
- Remove air dam. Retain all hardware. **The air dam will not be reinstalled.**
- Remove bumper by first removing bolts from the outer bumper support brackets at ends of bumper, leaving the other end of bracket attached to the vehicle frame. Next remove the three (3 ea.) center bumper bracket mounting bolts on the L.H. (driver) and R.H. (passenger) side of vehicle frame. **Retain all hardware. Bolts will not be reused.**
- Position clevis frame (1) over the end of vehicle frame. Attach clevis frame (1) using 1/2-13 x 1-3/4" bolts (8), flatwashers(15) and locknuts (12). **Do not tighten at this time.**
- Remove forward bolts from sway bar brackets. **Retain bolts. They will not be reused.**
- Position spacers (6) at holes "A" on vehicle crossmember.

- Install clevis support brace (2) on top of spacers (6). Attach at holes "A" using 7/16-14 x 2-1/2" bolts (7), flatwashers (14) and locknuts (11).
- Attach clevis support brace (2) to clevis frame using 1/2-13 x 1-3/4" bolts (8) and locknuts (12)
- Re-install bumper.

**Note: Before tightening the fasteners, the clevis frame should be pushed as far as possible under the vehicle.**

- Tighten all fasteners to their proper torque. Tighten bolts in the same order they were assembled to vehicle.

**Important Notice: Prior to installation of the lift frame (17), it will be necessary to identify the lift frame being installed. Current production lift frames have additional stops (Part No. 10626) tack welded to the existing stops. (See illustration.) Earlier production lift frames will not have these stops. Depending upon the S.A.F. Carton being installed, additional stops may need to be added or removed.**

- When installing S.A.F. Carton 16503, 16504 lift frame should **retain** additional stops Part No. 10626).

**Note: Before installing lift frame tubing to clevis frame, liberally coat ends of lift frame with chassis grease / anti-seize lubricant.**

- Install Lift Frame (17) into the tubes on the clevis frame. Turn adjusting bolts in until contact is made with lift frame.

**Caution: Do not over tighten adjustment bolts. Adjust bolts for minimum clearance between lift frame and receiver tubes while still allowing for ease of lift frame removal. See illustration. Secure lift frame (17) to clevis frame (1) using hinge Pins (6) and hair pin cotters (16).**

- Attach lift arm (4) to lift frame (17) using 5/8-11 x 3-1/4" bolt (10) and locknut (13). Mount Hydraulic unit to lift frame using 5/8-11 x 3-1/4" bolt (10) and locknut (13), and to lift arm (4) using 5/8-11 x 2-3/4" bolt (9) and locknut (13). **(SEE WARNING)**
- Install hydraulic system and snow plow lights per separate instructions.
- Pre-Assemble Moldboard Assembly, A-Frame (18), Sector, ect., per separate instructions.
- Hook the A-Frame chain to the Lift Arm (4) allowing sufficient slack to enable the Moldboard to follow ground contour while plowing.

**Note: When the lift frame module (17) is removed from the vehicle, the insides of the clevis frame (1) receiver tubes and outside ends of the lift frame should be coated with chassis grease/anti-seize lubricant and the protective receiver tube caps (4) install over the clevis frame receiver tubes.**

**Meyer Products assumes no responsibility for installations not made in accordance with these instructions.**