

# Installation and Operational Manual

## UTGS CONTRACTOR SPREADER



**Meyer**<sup>®</sup>

# Installation and Operational Manual

## Contents

SAFETY INFORMATION-----	3-5
HYDRAULIC SPECS, DIAGRAMS	
AN INSTALLATION INSTRUCTIONS-----	6-10
TROUGH MOUNTING INSTRUCTIONS-----	11-12
SPINNER MOUNTING INSTRUCTIONS-----	13-15
OPERATING INSTRUCTIONS-----	16-17
SPINNER SPREAD PATTERN INSTRUCTION-----	19-20
RECOMMENDED MAINTENANCE-----	21
-	
HYDRAULIC TROUBLESHOOT GUIDE-----	22
UTGS SPREADER PARTS LISTING AND DIAGRAMS-----	23-31
UTGS SPINNER PARTS LISTING AND DIAGRAMS-----	32-33
NAME PLATE IN FORMATION-----	34
WARRANTY-----	35

# Installation and Operational Manual

## SAFETY PRECAUTIONS

The best safety device is a careful operator!



This symbol means ATTENTION!  
Become Alert!  
Your safety is involved!  
Please read and understand completely before operating!

 Improper use of this equipment can result in serious injury. To reduce this possibility, give complete and undivided attention to the job at hand, and follow these safety precautions.

### Preparation

Know your controls. Read this instruction manual. Learn how to stop the equipment quickly in an emergency.

Do not allow children to operate machine; nor adults to operate it without proper instructions.

Keep all individuals not involved in the use of the equipment a safe distance away.

### Operation

Observe and shut off all equipment controls before starting engine so equipment will not unintentionally operate when engine is started.

Always check area around machine before engaging or operating controls.

Always wear relatively tight and belted clothing when operating equipment. Loose jackets, shirts, sleeves or other loose clothing should not be worn because of the danger of catching them in moving parts or controls.

Stop and inspect equipment if unusual movement, sounds or noises are observed. Repair damage before restarting and operating the equipment.

Disengage power to all operating equipment: (1) before leaving operator's position, (2) before making any repairs, adjustments, or cleaning, or (3) when not in use.

Take all possible precautions when leaving the equipment unattended; such as disengaging the hydraulic system from the vehicle engine, shifting vehicle out of gear, setting parking brake, shutting off engine and removing key.

---

### NOTICE:

It is the responsibility of the owner of this spreader to replace any or all safety decals which become unreadable or otherwise defaced, and to apply the new decals to the spreader in a secure manner in the same location as the old decals.

Read and observe all **“DANGER”** and **“CAUTION”** safety decals appearing on equipment.

The following safety decals appear in various locations on your equipment. The sizes of the decals shown in this manual have been reduced in order to save space. Refer to page 4 for location and size of safety decals on your equipment.

# Installation and Operational Manual

## NOTICE!

Your spreader is equipped with a safety interlock device. This device must be disconnected before the spreader trough bottom door and the spreader trough top cover can be opened exposing the auger. This device positively disconnects all hydraulic power from the auger drive motor to prevent accidental bodily injury due to contact with a turning auger.

**! DANGER**

SERIOUS PERSONAL INJURY OR DEATH CAN RESULT  
IF THE SAFETY INTERLOCK DEVICE - AS INSTALLED ON THIS SPREADER:  
● IS ALTERED IN ANY WAY FROM ITS ORIGINAL INTENT AS SHOWN  
● IS NOT MAINTAINED SO AS TO OPERATE ACCORDING TO ITS ORIGINAL INTENT AS SHOWN

HOSE MUST FEED THROUGH SLOT IN BACK OF SPREADER AFTER LATCH HANDLE IS FULLY CLOSED  
SPREADER WILL OPERATE  
TOP COVER CANNOT BE OPENED REARWARD AND BOTTOM DOOR CANNOT BE OPENED EXPOSING AUGER

HOSE MUST BE REMOVED FROM SLOT SO LATCH HANDLE CAN BE OPENED  
SPREADER WILL NOT OPERATE  
TOP COVER AND BOTTOM DOOR CAN BE OPENED

IF DEFACED - ORDER PART NO. 04049 393 00

This decal appears on the back of the spreader cover plate at the right end of the spreader. It alerts all to the danger associated with the improper use of the Safety Interlock Device.

**! CAUTION**

1. KEEP ALL SHIELDS IN PLACE.
2. MAKE CERTAIN EVERYONE IS CLEAR BEFORE STARTING MACHINE OR MOVING VEHICLE.
3. KEEP HANDS, FEET, AND CLOTHING AWAY FROM ALL POWER DRIVEN PARTS.
4. DISENGAGE PTO, SHUT OFF HYDRAULIC VALVE, AND SET PARKING BRAKE BEFORE LEAVING OPERATORS POSITION. MAKE SURE ALL MOVEMENT HAS STOPPED BEFORE SERVICING, UNCLOGGING, OR CLEANING MACHINE.
5. USE FLASHING LIGHTS WHEN OPERATING MACHINE.
6. MAKE SURE MACHINE IS SOLIDLY SUPPORTED WHEN IT IS BEING MOUNTED, DISMOUNTED, OR STORED.

IF DEFACED - ORDER PART NO. 04049 045 00

This decal appears on the left end, or the right end of the spreader trough. It cautions all to observe general safety procedures when operating this equipment.

**! DANGER**

Turn power off before servicing or cleaning

IF DEFACED - ORDER PART NO. 04049 123 00

This decal appears on the back of the spreader trough cover plate. It alerts all to the danger of being caught in the dropout opening or from the top of the spreader trough where serious personal injury could result.

**! DANGER**

Stay clear while spinner is turning

IF DEFACED - ORDER PART NO. 04049 044 00

This decal appears near the spinner assembly on the back of the spreader trough cover plate. It alerts all to the danger of being struck by material being spread by the spinner assembly which could result in serious personal injury.

# Installation and Operational Manual

## LOCATION OF SAFETY DECALS

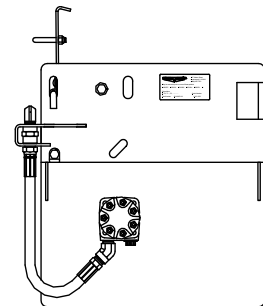
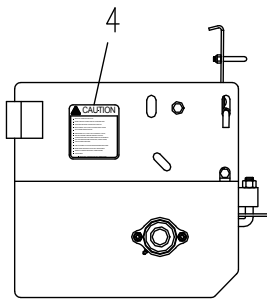
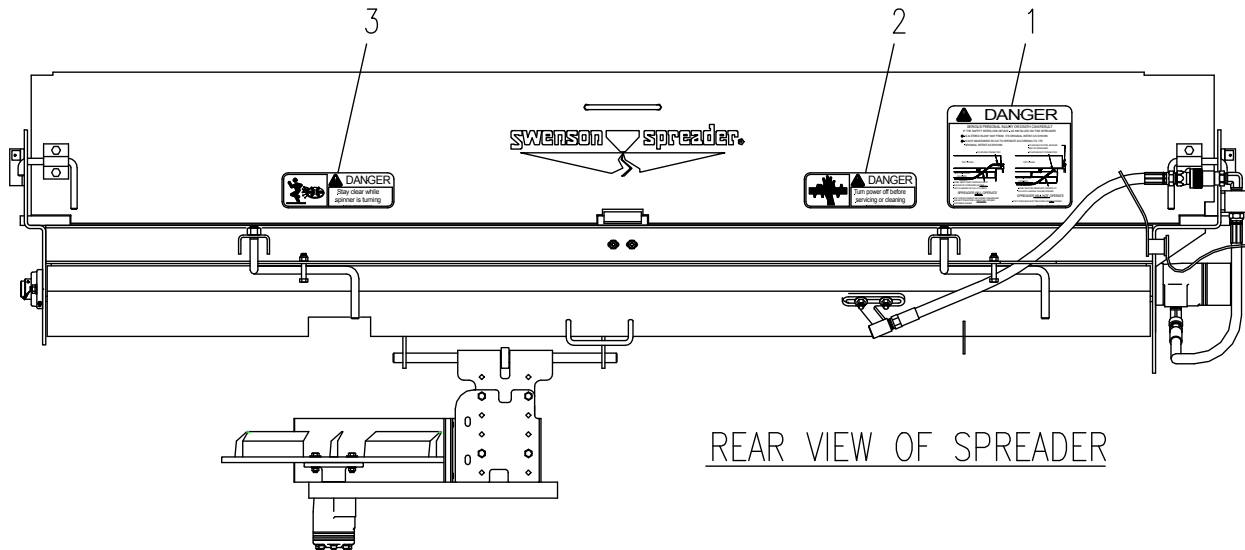

S:\MANUAL\TAILGATE\S SERIES\SAFETY DECAL LOCATION - SAD1

<u>Decal</u>	<u>Part Number</u>	<u>Qty.</u>	<u>Description</u>
1	64266	1	Safety Interlock Decal (8" x 10" Red, White & Black)
2	62515	1	Auger Danger Decal (9" x 2 3/4" Red & White)
3	62006	1	Spinner Danger Decal (9" x 2 3/4" Red & White)
4	62007	1	General Caution Decal (4 1/4" x 4" Yellow & Black)

Refer to pages 34 & 35 for complete drawing and parts list for Safety Interlock device.

# Installation and Operational Manual

## CONTROL HYDRAULICS SPECIFICATIONS AND INSTALLATION

### CONTROL AND HYDRAULIC SYSTEM SPECIFICATIONS:

- Hydraulic Oil ----- Good Grade of MS10W Hydraulic Oil which has wear, oxidation and foam inhibitors.
- Oil Filter ----- 10 Micron Element In Return Line
- Relief Valve Setting ----- 1500 PSI
- Oil Flow ----- Conveyor (A-Port) 0-15 GPM  
Spinner (S-Port) 0-7 GPM

# Installation and Operational Manual

## CONTROL HYDRAULICS INSTALLATION

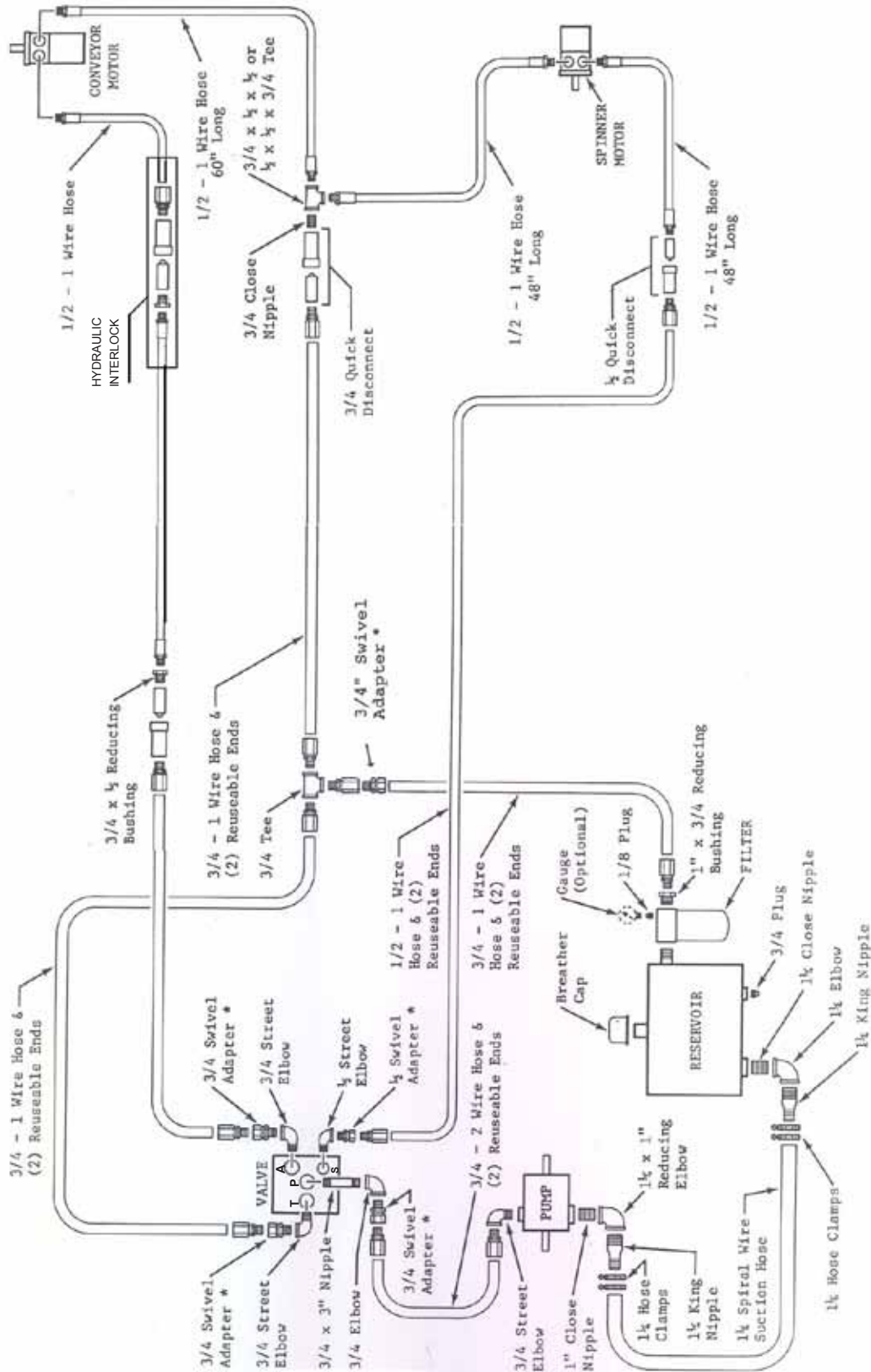

# Installation and Operational Manual

## CONTROL HYDRAULICS INSTALLATION (Continued)

1. This diagram is Meyer Products complete recommended hydraulic system.
2. Standard pump, valve, tank and hose kits make up the complete system.
3. This diagram may be used to install an entire system, or part of a system, depending upon kits supplied, and existing components on truck.
4. Alternate proven methods and components are acceptable to suit various truck model requirements.
5. Hydraulic components should be kept as clean as possible during assembly operations.
6. Galvanized pipe and pipe fittings should not be used because flaking of galvanizing material can cause damage to major hydraulic components.
7. A pipe joint sealant, compatible with hydraulic oil, must be applied to all screwed fittings. (Teflon tape is not recommended.)
8. Sufficient hose should be allowed for raising dump body without kinking or stretching hose.
9. Hose should be protected where severe wear may be caused by vibration or sliding movement.
10. Long runs of hose should be supported by nylon ties or clamping.
11. Auger and Spinner pressure and return hoses may be reversed for proper motor rotation.
12. Three hose lines to rear of truck may be installed inside truck frame, under dump body floor, and secured in place.
13. Use hose manufacturers recommendations for fitting reusable hose ends.

# Installation and Operational Manual

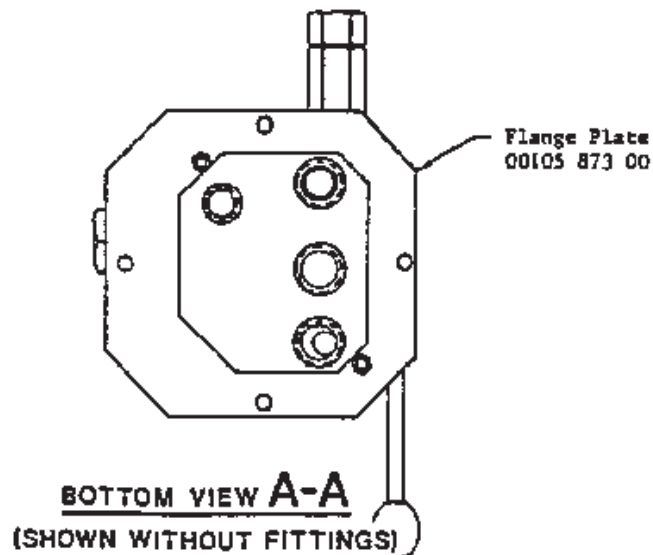
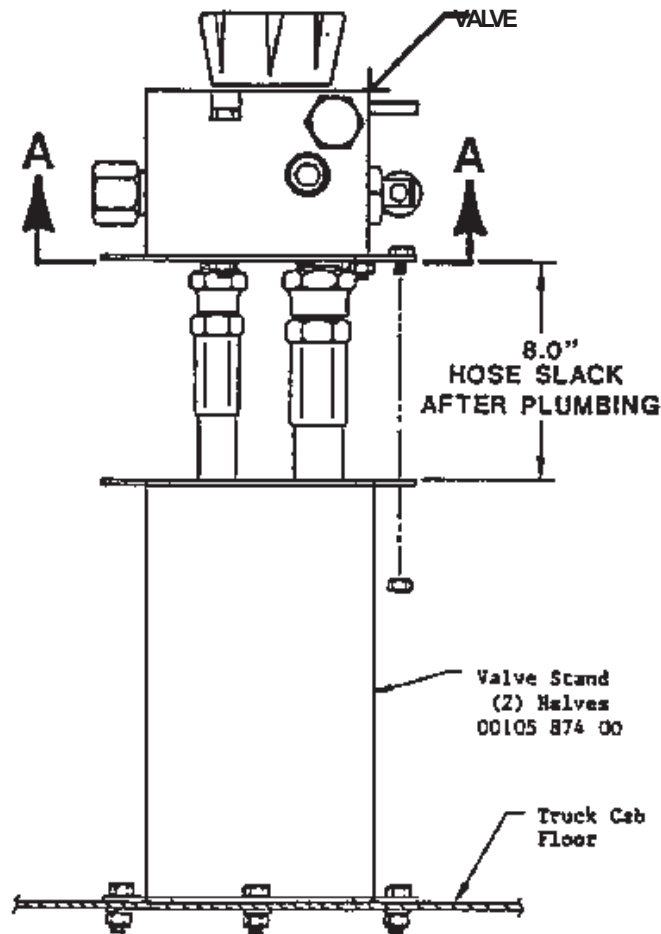

## DUAL FLOW CONTROL VALVE INSTALLATION INSTRUCTIONS







1. **IMPORTANT:** A pipe joint sealant compatible with hydraulic oil must be applied to all screwed fittings. (Teflon Tape Sealant is Not Recommended)
2. Hose ends connected to valve must be of the "swivel" type.
3. **CAUTION:** Overtightening of the fittings in flow valve may cause damage to valve body.
4. Approximately 8" of hose slack must be allowed between the valve and the valve stand after the valve has been completely plumbed. If this condition does not exist after the plumbing has been completed, removal of valve will require hoses to be removed at opposite end of hoses.
5. Assembly of valve on stand:
  - a. Cut a 5" x 5" square opening in floor of truck where the valve stand is to be located.
  - b. Bolt valve stand halves together forming a "box" over the 5" x 5" square opening. **NOTE:** When bolting valve stand halves in place, make sure holes in flanges of halves align with holes in flange plate.
  - c. Bolt flange plate to VALVE. (Use (2) 1/4" x 3" bolts, lockwashers, and nuts.)
  - d. Insert hoses through floor opening and valve stand and connect appropriate hoses to valve. (See instruction #1 thru #4.)
  - e. Bolt flange plate to valve stand flanges.

(See page 37 for parts list.)

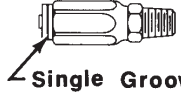
# Installation and Operational Manual

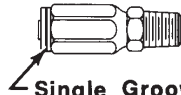
## HOSE END ASSEMBLY INSTRUCTIONS

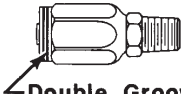
### FITTING IDENTIFICATION

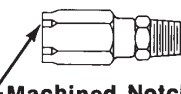
	GATES	AEROQUIP	PARKER
$\frac{1}{2}$ " 1 WIRE	 Single Groove	 Plain Machining	 Plain Shoulder
$\frac{3}{4}$ " 1 WIRE	 Single Groove	 Plain Machining	 Plain Shoulder
$\frac{3}{4}$ " 2 WIRE	 Double Groove	 Large Groove	 Machined Notches

### HOSE IDENTIFICATION

(Locate SAE number printed on hose as shown below)

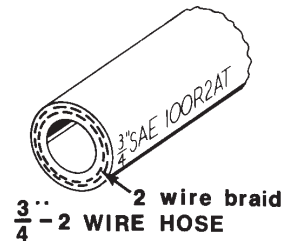
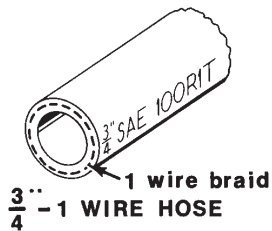
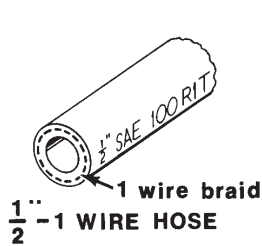

### ASSEMBLY INSTRUCTIONS

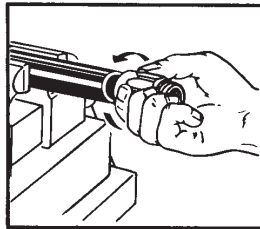

#### Step 1

Liberally oil hose cover with lube oil, place hose in vise just tight enough to prevent it from turning. Screw socket onto hose counter-clockwise until it bottoms. Back off 1/2 turn.

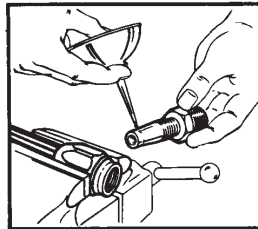

#### Step 2

Oil nipple threads and inside of hose liberally.

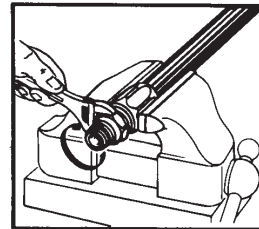

#### Step 3

Screw nipple clockwise into socket and hose. Leave 1/32" to 1/16" clearance between nipple hex and socket. Clean and inspect all assemblies. Disassemble in reverse order.

# Installation and Operational Manual

## TROUGH MOUNTING INSTRUCTIONS

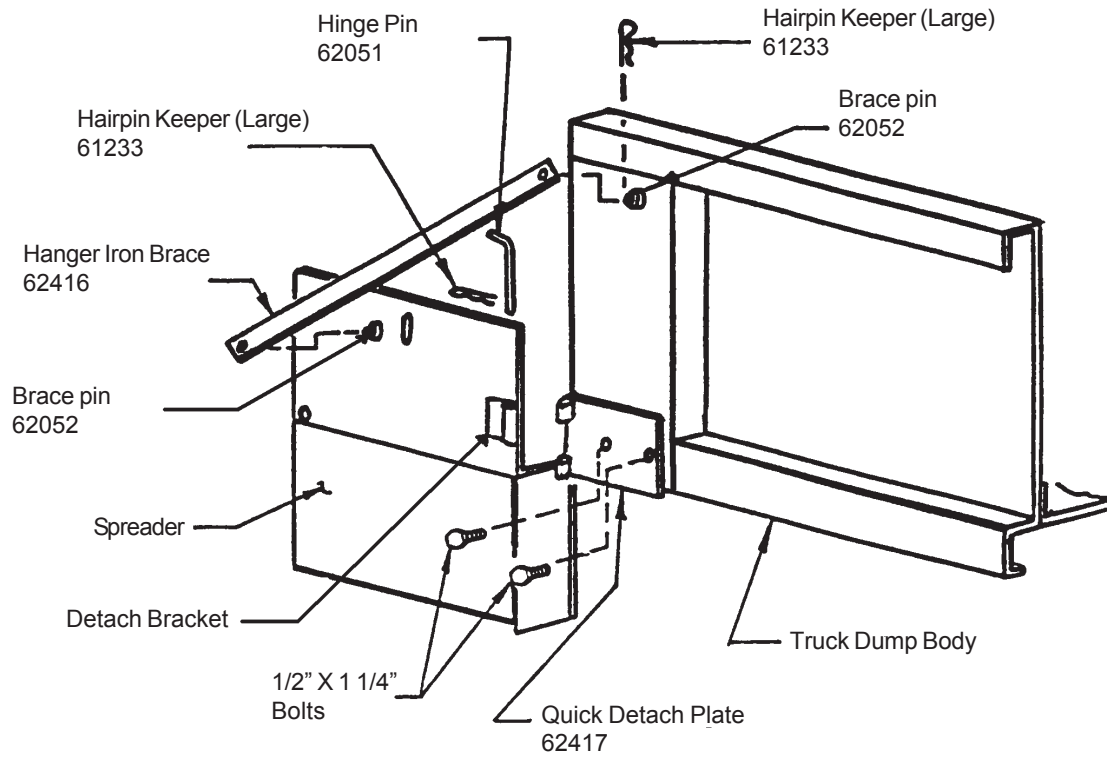

# Installation and Operational Manual

## TROUGH MOUNTING INSTRUCTIONS

(Continued)

### GENERAL:

This spreader is designed to mount rigidly on the rear of the truck dump body, below the tailgate, and supported by brackets bolted to the rub rails of the dump body. Instructional drawing is included in this manual to show the details on page 10.

### DANGER

Support spreader and other heavy components solidly when positioning for mounting on truck dump body.

### IMPORTANT:

On occasion, due to improper handling during shipment or storage, the vertical ends of the trough get bent in or out slightly. Be sure these are square and true before installation. Once installed, the mounting brackets should prevent further deformation.

1. Position the spreader under the dump body tailgate with the auger drive housing to the right side of the truck. The trough lip on the forward side of the spreader should be as close as possible to the cross member under the floor of the dump body.

The tailgate of the dump body should lay down horizontally over the spreader, yet the spreader must be mounted up under the tailgate as high as possible.

2. Pin quick detach plates to spreader detach brackets.
3. Position quick detach plates against dump body cornerposts and clamp in a level position. Weld adequately to support loaded spreader trough. If bolting, is desired, drill (2) holes for 1/2" bolts simultaneously through bracket and cornerpost and bolt solidly.
4. Position hanger iron brace on brace pin located on spreader endplates.
5. Locate brace pins on dump body cornerposts approximately as shown using braces for exact positioning. (Braces may require bending for proper fit.)
6. Weld brace pins solidly to dump body, and retain braces at each end with hairpin keepers.
7. Carefully remove temporary spreader positioning apparatus.
8. If there is a gap between the trough lip and the dump body rear cross member, a "spillboard" of about 3/16" x 2" steel may be welded or bolted to the forward lip of the spreader to form a seal under the dump body floor. It may have to be notched or cut to fit around tailgate latches or other obstructions on the rear of the dump body.
9. Tailgate shields (**62412**), if required, are bolted or welded to the inside of the tailgate to prevent material spillage over the ends of the spreader.

# Installation and Operational Manual

## INSTALLATION OF SPINNER ASSEMBLIES ON

 **DANGER** SUPPORT SPINNER ASSEMBLY SOLIDLY WHEN MOUNTING ON SPREADER.

### SPINNER ASSEMBLY PROCEDURE:

1. Attach spinner shield to spinner frame with 5/16" x 3/4" bolts and nuts.
2. Attach spinner disc to hub with 5/16" x 1 1/2" bolts, flatwashers and flange nuts.
3. Apply anti-seize compound to spinner motor shaft.
4. Mount spinner disc/hub assembly on spinner motor shaft.
5. Secure disc/hub assembly to motor shaft with proper size hardware (provided). Bolt should engage threads in motor shaft a minimum of 3/8" when bolt is tight.
6. Attach spinner frame assembly to spinner extension mounting bracket with (4) 3/8" X 1" bolts and flange nuts.
  - a. Appropriate spinner height depends on truck frame ground clearance. A shorter spinner height for light and medium duty trucks with contractor style bodies, a taller spinner height for heavy duty trucks with full size dump bodies.
7. While holding lock collar in middle notch of spinner extension mounting bracket, slide spinner hinge rod through both the mounting bracket and lock collar.

### MOUNTING PROCEDURES:

TRUCK SHOULD BE ON LEVEL SURFACE.

1. Install spinner assembly on spreader by sliding the hinge rod into the mounting tabs on bottom door. Insert (2) keeper pins into hinge rod. Center and lock spinner assembly between mounting tabs.
2. Raise and lower dump body to check spinner ground clearances. Adjust spinner height if needed. Repeat step if adjustments are made.

# Installation and Operational Manual

## INSTALLATION OF SPINNER ASSEMBLIES ON

3. Position spinner linkage bar under spinner frame channel so that L-Bend aligns with truck frame. Secure linkage bar to spinner frame with 5/16" X 1" bolt and flange nut, using the inside mounting hole. (Outside mounting hole is for hydraulic hose clamp.) Cut off any excess linkage bar if required.
4. With spinner disc level with ground, measure and record the distance between centerline of spinner hinge rod(s) and centerline of hole in spinner linkage bar(s) for dimension "X". Measure and record the space between centerline of dump body hinge pins and centerline of spinner hinge rod(s) for dimension "Y".

DIMENSION "X" \_\_\_\_\_

DIMENSION "Y" \_\_\_\_\_

5. Temporarily clamp frame bar(s) in position (hole pointing down) against truck frame. Locate mounting hole below dump body hinge pins using "X" and "Y" dimensions from step 5.
6. Attach parallel linkage rods to the frame bars and in the spinner linkage bar(s) with 1/2" flatwasher and keeper pins. Overlap and temporarily clamp rods together.
7. Raise and lower dump body while checking spinner for binding and level operation at all dump angles. Check that temporary connection bars are not moving.
8. Secure frame bar(s) to truck frame in compliance with truck manufactures recommendations. Weld parallel linkage rod together. Remove all temporary clamps.
9. Attach spinner hydraulic hoses to spinner motor (use pipe thread sealant if applicable). Secure hoses to spinner frame with clamp and hardware provided.

# Installation and Operational Manual

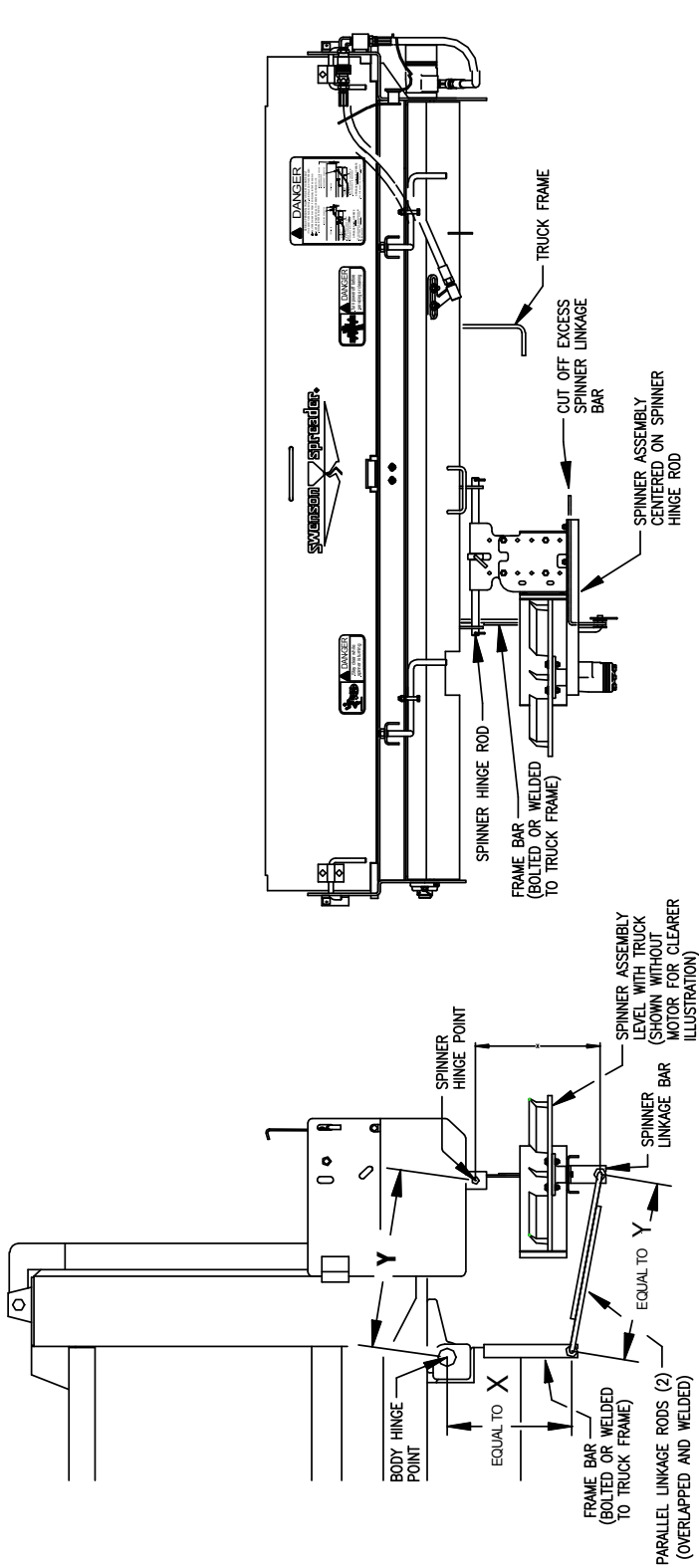

**NOTE:**  
 FOR SPINNER ASSEMBLY TO REMAIN LEVEL AT ALL DUMP BODY ANGLES, IT IS IMPORTANT THAT "x" AND "y" DIMENSIONS BE MEASURED ACCURATELY, AND THEN DUPLICATED WITH PARALLEL LINKAGE ROD SPACING, AND CENTER SPACING BETWEEN BODY HINGE POINT AND HOLE IN LOWER END OF FRAME BAR

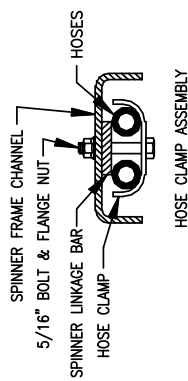
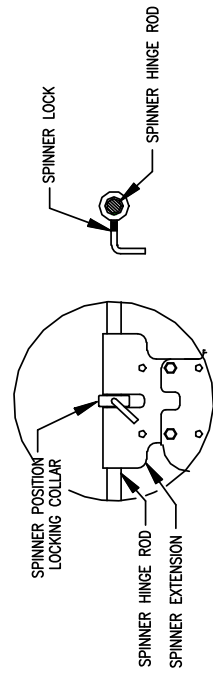

S:\MANUALS\VALGATE\S SERIES\SPINNER MOUNTING

LEFT HAND (CCW) SPINNER ASSEMBLY  
 S SERIES SPREADER

# Installation and Operational Manual

## OPERATING INSTRUCTIONS

### **DANGER**

1. WHEN STARTING UP NEW EQUIPMENT, BE SURE EVERYONE IS STANDING CLEAR, WATCH FOR ANYTHING THAT MAY REQUIRE SHUTTING SYSTEM DOWN. EQUIPMENT MUST BE STARTED UP SLOWLY AND WATCHED FROM A SAFE DISTANCE. WATCH FOR ANYTHING THAT MAY BE HITTING SOMETHING THAT IT SHOULD NOT BE HITTING, AND LISTEN FOR SOUNDS THAT ARE ABNORMAL. CORRECT ANYTHING THAT IS ABNORMAL BEFORE CONTINUING USE OF THE EQUIPMENT.
2. BEFORE INSTALLATION, MAINTENANCE, CLEANING, OR REMOVAL OF SPREADER, ALL HYDRAULIC VALVES, PTO, AND TRUCK ENGINE MUST BE SHUT OFF.
3. WHEN SPREADER IS REMOVED FROM VEHICLE, OR NOT IN USE, THE VALVE ON-OFF LEVER SHOULD BE IN THE "OFF" POSITION. IF LEFT IN "ON" POSITION EXCESSIVE HEAT MAY OCCUR IF PUMP CONTINUES TO PUMP OIL THROUGH THE HYDRAULIC VALVE. THIS THEN COULD CAUSE A HOSE TO BURST SPRAYING HOT OIL ON THOSE NEARBY.

#### **INITIAL START UP:**

This spreader is equipped with a hydraulic safety interlock device designed to interrupt oil flow to the auger motor when disconnected. The spreader is shipped with the interlock device in the disconnected position and must be connected for operating the spreader.

1. Connect hydraulic hoses to safety interlock, spreader and spinner.
2. Fill reservoir about three-fourths full with hydraulic oil. (See page 5 for type.)  
KEEP OIL CLEAN.
3. Start truck engine.
4. Be sure valve ON-OFF lever is in "OFF" position.
5. Keep auger and spinner knobs on valve in closed position.
6. Engage PTO and allow hydraulic oil to circulate several minutes to warm up.
7. Open both valve knobs to first position.
8. Move valve ON-OFF lever to "ON" position.
9. Examine auger and spinner to see if they are functioning properly. (They will be operating slowly.) (Left hand mounted spinner should turn in CCW rotation, and right hand mounted spinner should turn in CW rotation, as viewed from above spinner. Auger should turn in direction which makes auger flitting appear to move towards trough dropout opening.)
10. Open valve knobs to other positions and check to see if spinner and auger operate faster as knobs are opened, and slower as knobs are closed.
11. Turn valve knobs to closed position and move ON-OFF lever to "OFF" position.
12. Shut truck engine off.
13. Check entire hydraulic system for leaks.
14. Refill reservoir to three-fourths full.
15. Hydraulic system is now ready for use.

# Installation and Operational Manual

## OPERATING INSTRUCTIONS

(Continued)

### PREPARING SPREADER FOR USE:

1. Position spreader cover plate vertically and secure with latches.
2. With dump body empty, unlatch dump body tailgate from bottom and open as wide as possible but not bearing against cover plate, set the stop (or spread) chains.
3. Loosen spinner lock and slide spinner assembly to far left and retighten lock. (Position for spreading three or four lane highway from right lane.)
4. Start truck engine and allow hydraulic system to warm up by shutting off spinner and auger knobs and moving ON-OFF lever to "ON" position.
5. Move ON-OFF lever to "OFF" position after warming up.
6. Put spreading material in dump body and raise dump body to fill spreader trough.
7. Lower dump body to safe position.
8. Open spinner and auger knobs, and move ON-OFF lever to "ON" position. Spread small amount of material to determine placement of material at various spinner and auger speeds with spinner in this far left position.
9. Move valve lever to "OFF" position and shut off truck engine.
10. Loosen spinner lock and slide spinner assembly to far right and retighten lock. (Position for spreading behind truck and to extreme right covering up to four lanes from left lane.)
11. Start truck engine.
12. Open spinner and auger knobs, and move ON-OFF lever to "ON" position. Spread small amount of material to determine placement of material at various spinner and auger speeds with spinner in this far right position.
13. It should now be visible that various spread patterns may be obtained by placing spinner at various positions from left to right, and by changing spinner speeds on valve.

### OPERATING SPREADER:

1. For operating hydraulic system, follow same procedures as for preparing spreader for use.
2. Any valve knob setting changes may be made while truck is in motion.
3. Spinner and auger may be stopped at the same time, without changing their valve settings, by moving ON-OFF lever to "OFF" position.
4. For normal use of dump truck, cover plate may be laid flat over spreader trough and locked in place. Dump body tailgate may be opened from top or bottom.
5. When using truck for normal hauling and dumping, it is recommended that hydraulic safety interlock be disconnected. Feed hose out of slot and place hose end in hose holder under bottom door. Push dust cap over disconnect at end of hose.
6. Pivot upper end of disconnect around to end of spreader. Push plug into end of disconnect while at same time position strap (on plug) in slot at forward end of fitting support bracket (which is welded to spreader endplate).
7. Refer to safety interlock danger decal on trough cover plate for proper use of safety interlock.
8. To avoid spinner damage, spinner may be removed when truck is used for extensive hauling. Protect hydraulic quick disconnects with appropriate plugs and caps.

# Installation and Operational Manual

# Installation and Operational Manual

## ADJUSTING SPINNER FOR DESIRED SPREAD PATTERN



### DANGER!

Serious personal injury can result from being caught in a turning spinner. Stay clear and keep all others clear when spinner is turning.

Serious personal injury can result if hit by flying particles being thrown by a turning spinner.

Stand back, and keep all others back at least 50 feet while spinner is turning. DO NOT ASSUME that particles cannot be thrown by a turning spinner just because material is not being dropped onto the spinner; particles that have been sticking to the spinner may suddenly come loose and be thrown causing possible injury.

In general, for the most commonly desired spread patterns, the material drop zone should be **over forward half** and **within outside edge of disc**. See below and next page. Adjusting the specific location where material falls on the forward half of the spinner disc is very important. This allows the greatest portion of the material to be placed on the road surface in the three most commonly desired locations: 1. To the left of the vehicle. 2. To the left and rear of the vehicle. 3. To the rear and right of the vehicle.

The spinner shield which is positioned approximately at the right forward quadrant of the spinner disc, is intended to restrict "stray" material to the spinner area and to aid in a more defined spread pattern.

Once the desired spread pattern has been obtained, increasing the spinner speed by opening the spinner control knob will give a wider spread pattern, and closing the spinner control knob will give a narrower spread pattern.

It should be noted that the spread pattern width will vary as the dump body is raised and lowered during spreading operations. This is due to the spinner becoming closer to the road surface as the body is raised, and farther away from the road surface as the body is lowered. A higher spinner assembly above the road surface will give a wider spread pattern, and a lower spinner assembly above the road surface will give a narrower spread pattern. When establishing spread pattern width, raise the body to the dump angle normally used during spreading operations, and have the spinner control knob at the setting normally used during spreading operations.

Sliding the spinner to intermediate positions from those shown below and on the following page will give variations of spread patterns to those shown. After establishing the desired spread pattern, it is suggested that the spinner position on the hinge rod, the dump body angle, and the valve spinner control setting be recorded for future use.

**IMPORTANT!** After making final adjustments, the spinner assembly must always be locked in position using the provided locking mechanism.

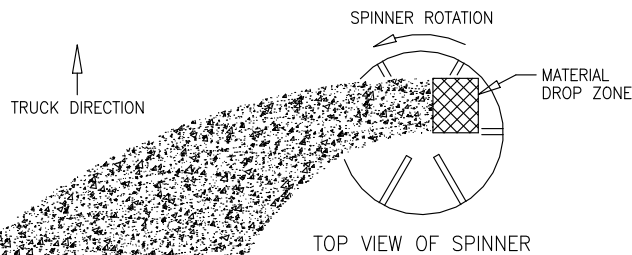
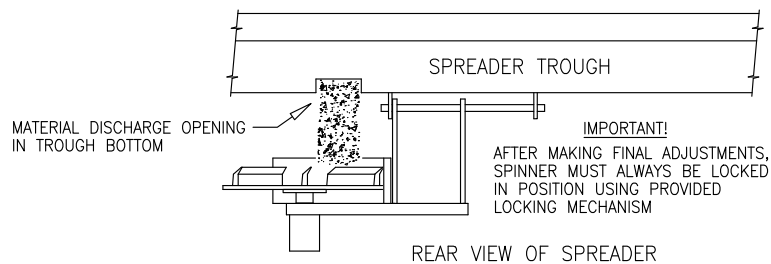

BULK OF MATERIAL IS SPREAD TO LEFT SIDE OF TRUCK WHEN SPINNER IS SLID TO FAR LEFT POSITION (AS SHOWN ABOVE). (DROP ZONE IS OVER RIGHT-FORWARD AREA OF SPINNER DISC)

SPREAD PATTERN RESULTING FROM SPINNER IN FAR LEFT POSITION

Z:\00111\00111-389-00RTJPD

# Installation and Operational Manual

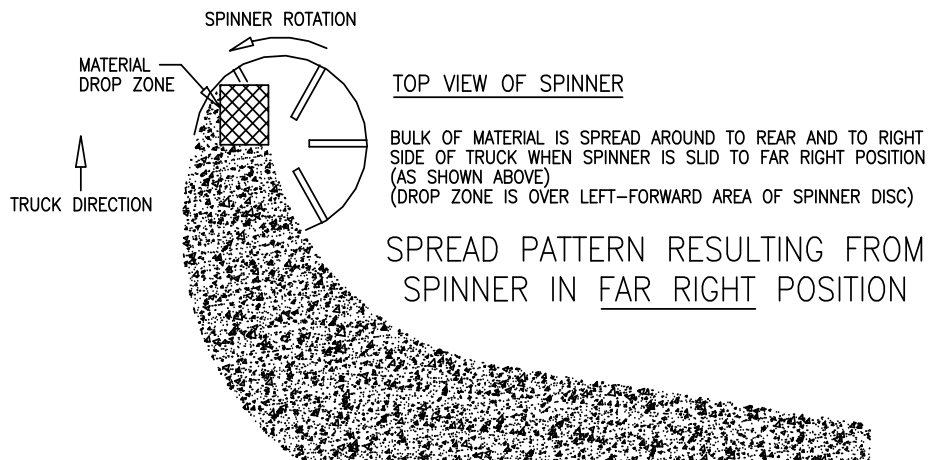
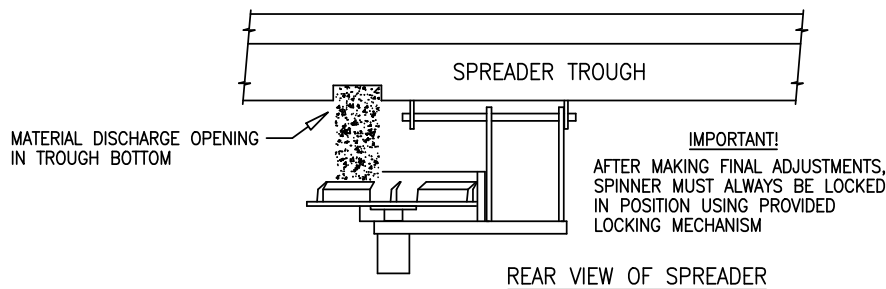
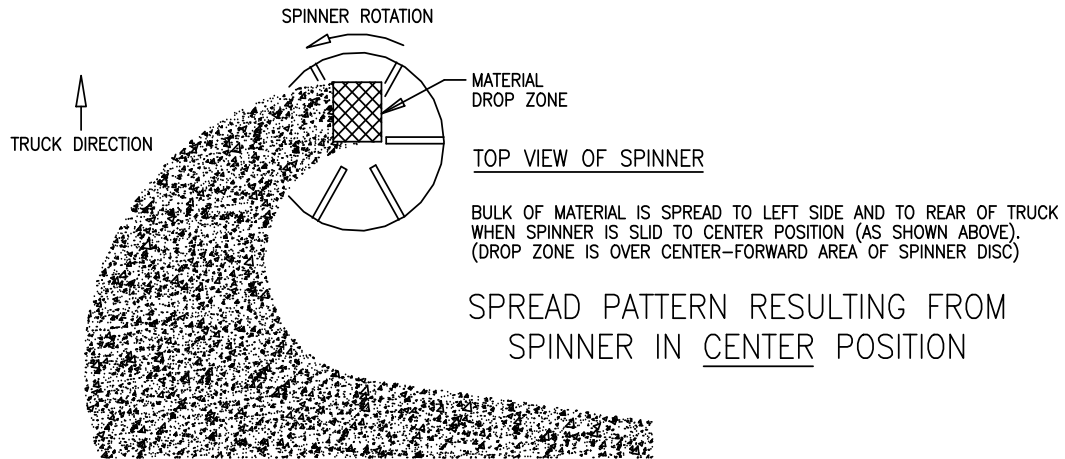
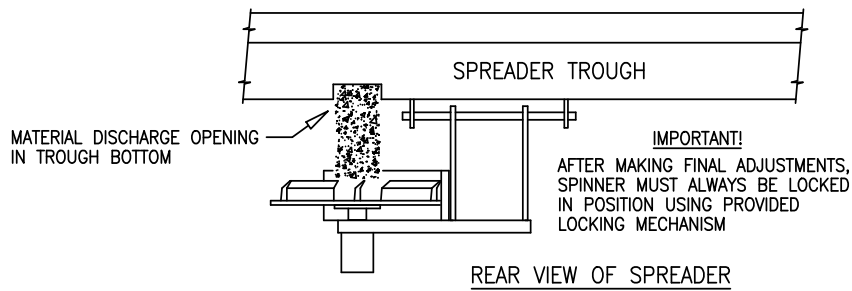

Z:\00111\00111-389-00RTJPD

# Installation and Operational Manual

## RECOMMENDED REGULAR MAINTENANCE

### **DANGER**

**SERIOUS PERSONAL INJURY CAN RESULT FROM BEING CAUGHT IN A TURNING AUGER, A TURNING SPINNER, OR OTHER OPERATING TRUCK EQUIPMENT. BEFORE PERFORMING MAINTENANCE OPERATIONS, PARK VEHICLE ON LEVEL GROUND. SET PARKING BRAKE, SHUT OFF ALL POWER, AND SHUT OFF TRUCK ENGINE. ALWAYS REPLACE SHIELDS AND COVERS WHEN MAINTENANCE IS COMPLETE.**

1. Maintain a three-fourths full reservoir using high grade non-foaming hydraulic oil. (See page 5.)
2. Avoid getting contaminants in reservoir when filling.
3. Replace filter cartridge with new cartridge at least twice a year and more often if necessary. (If installed, filter condition gauge has red zone indicating when cartridge needs changing.)
4. Clean hydraulic quick disconnects before taking apart or connecting.
5. Protect hydraulic quick disconnects while in use and after taking apart with oily rag or other suitable protection.
6. Auger bearing requires periodic greasing every 15 hours of use and more frequent greasing during periods of greater use.
7. Greasing spinner hinge rod at support pivot points is suggested.
8. Hosing down and cleaning spreader after each use, and repainting or oiling after each season will greatly prolong spreader life. To open bottom door and top cover, disconnect hydraulic safety interlock and pivot around to end of spreader.
9. Spreader trough should be completely emptied after each use during severe cold weather to prevent material from freezing around auger.

# Installation and Operational Manual

## HYDRAULIC TROUBLE-SHOOTING CHART

### CONDITION 1

Pump cavitation recognized by excessive noise.

#### CAUSE

- a. Air entering system through suction lines.
- b. Suction line kinked, twisted or too long.
- c. Inadequate size suction line.
- d. Hydraulic oil too heavy.
- e. Excessive pump speed. Normal pump speed should be 1200 to 1500 RPM.

#### CORRECTION

- a. Check line from reservoir for possible leaks.
- b. Install suction line as short and straight as possible.
- c. Increase suction line size.
- d. Drain and replace with a lower viscosity hydraulic oil.
- e. Pump capacity is 16 GPM at 1000 RPM. Decrease PTO speed accordingly.

### CONDITION 3

Erratic operation of auger and/or spinner.

#### CAUSE

- a. Low Oil.
- b. Worn or defective motor.
- c. Dirty, worn or defective flow control valve.
- d. Plugged filter.
- e. Relief valve setting too low.
- f. Pump cavitation.
- g. Air vent on reservoir tank is blocked.

#### CORRECTION

- a. Fill reservoir to a 3/4 full level.
- b. Repair or replace motor.
- c. Clean repair or replace flow control.
- d. Replace filter element and clean filter base.
- e. Adjust relief valve for 1500 PSI.
- f. Refer to condition 1.
- g. Clean or replace vent cap to admit atmospheric pressure to inside of tank.

### CONDITION 2

Slow operation of auger and/or spinner.

#### CAUSE

- a. Worn or defective pump.
- b. Worn or defective motor.
- c. Pump cavitation.
- d. Insufficient pump speed.

#### CORRECTION

- a. Repair or replace pump.
- b. Repair or replace motor.
- c. Refer to pump section.
- d. Pump capacity is 16 GPM at 1000 RPM. Increase PTO accordingly.

### CONDITION 4

Auger and/or spinner will not operate, or operates in wrong direction.

#### CAUSE

- a. Quick disconnects are dirty or damaged causing incomplete connection.
- b. System hose connections wrong.
- c. Hose connections wrong, causing motors to operate in wrong direction.
- d. Foreign material in valve compensator section.

#### CORRECTION

- a. Clean or replace and properly connect.
- b. Refer to plumbing diagram for proper hose connections, and reconnect.
- c. Refer to illustration for proper hose connections at motor and reconnect.
- d. Remove compensator section and clean.

NOTE: If a motor operates in the wrong direction, reverse hose connections at motor ports (usually easier).

**NOTE: Meyer Products Inc. warranty does not cover unauthorized disassembly of hydraulic pumps, motors, valves or electric components.**

# Installation and Operational Manual

## UTGS SPREADER PARTS LISTING AND PARTS DIAGRAMS

# Installation and Operational Manual

## REAR VIEW WITH TOP COVER OPEN

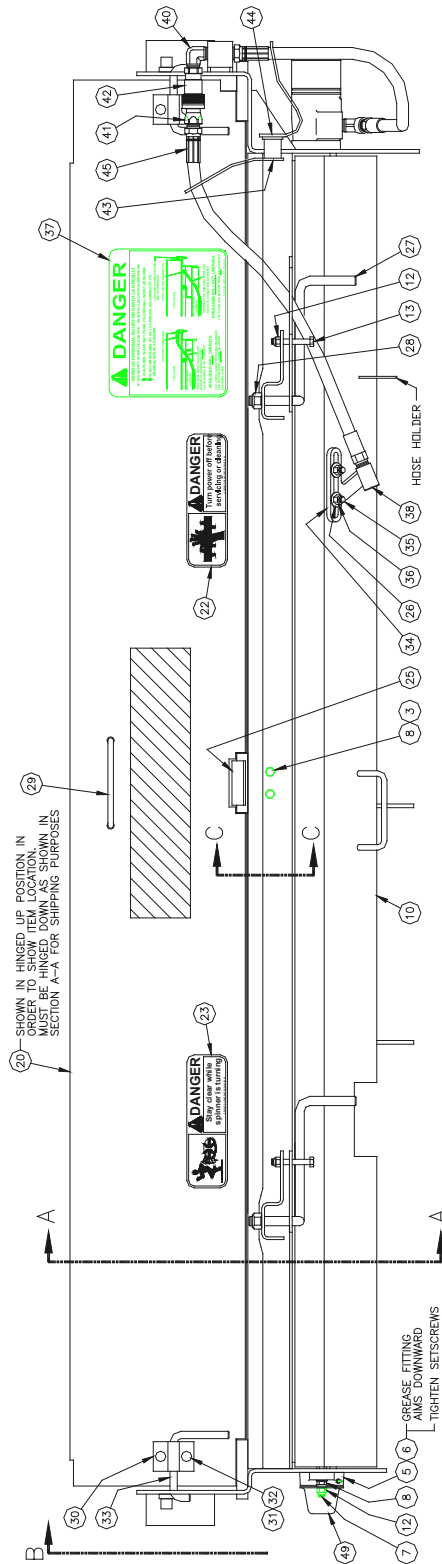

# Installation and Operational Manual

## TOP VIEW WITH TOP COVER OPEN

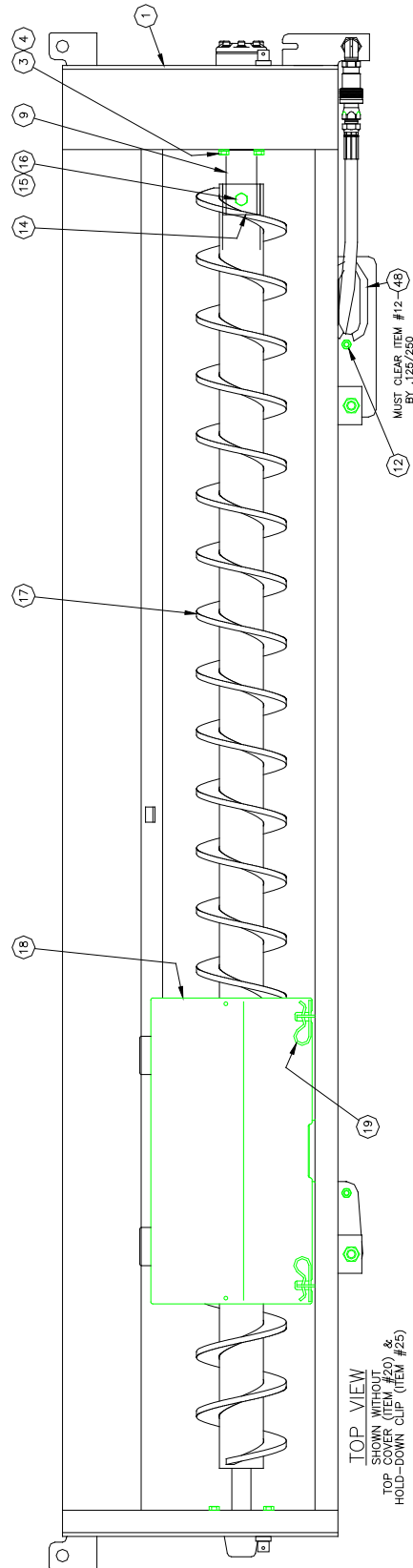

# Installation and Operational Manual

## TOP COVER HOLD DOWN DETAIL

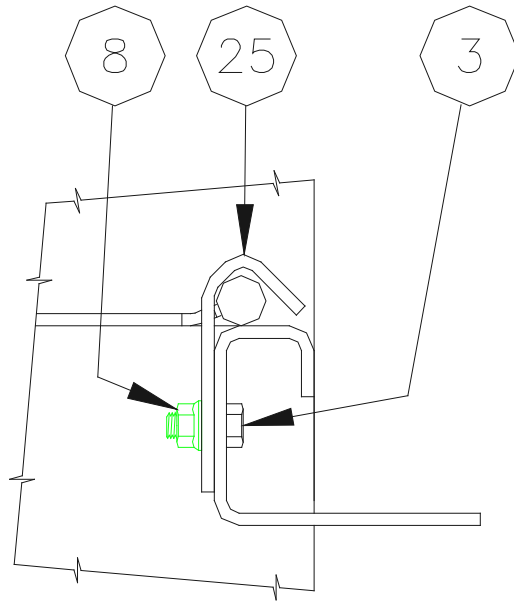

SECTION C—C

# Installation and Operational Manual

## DRIVE END VIEW

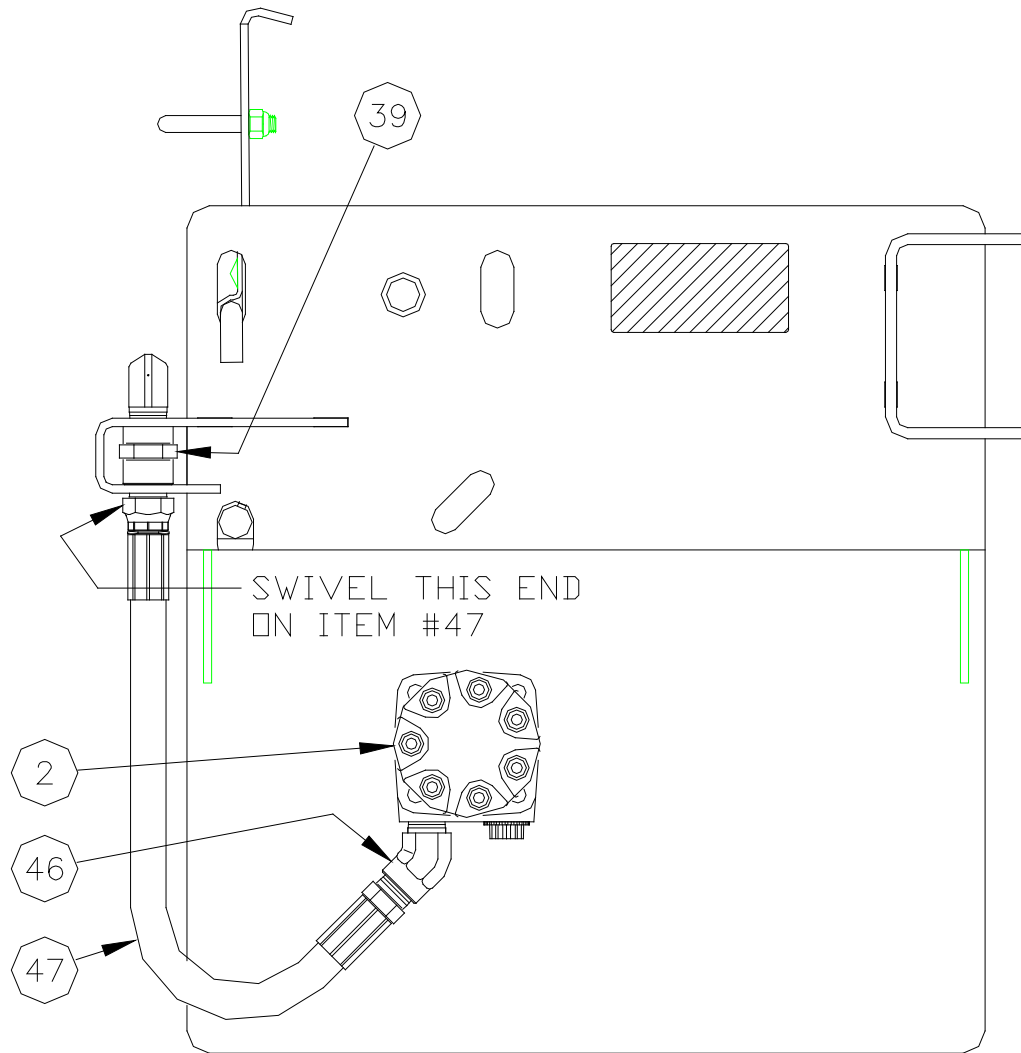

# Installation and Operational Manual

## BEARING END VIEW CROSS-SECTION

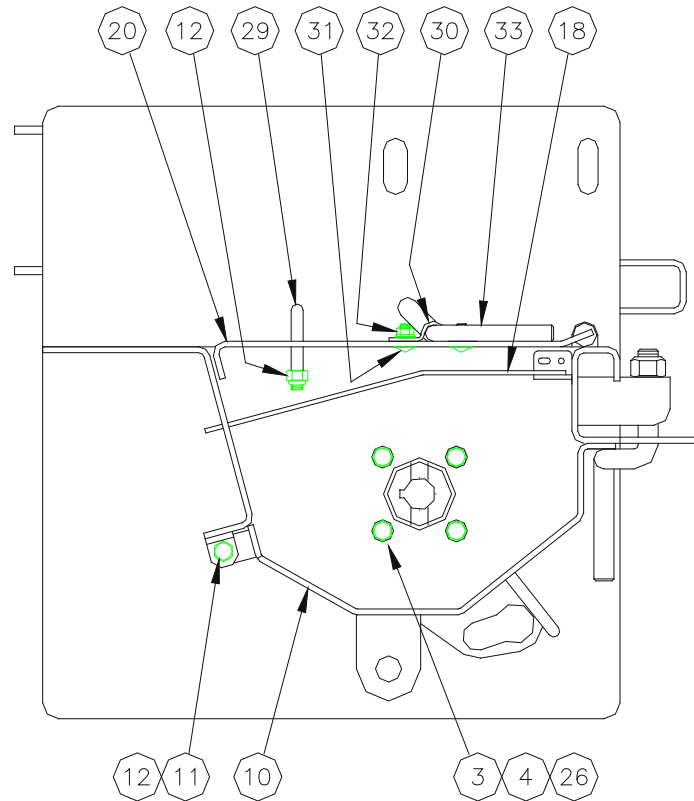

SECTION A-A  
(SHOWN WITHOUT AUGER)

# Installation and Operational Manual

## BEARING END VIEW CAUTION DECAL PLACEMENT

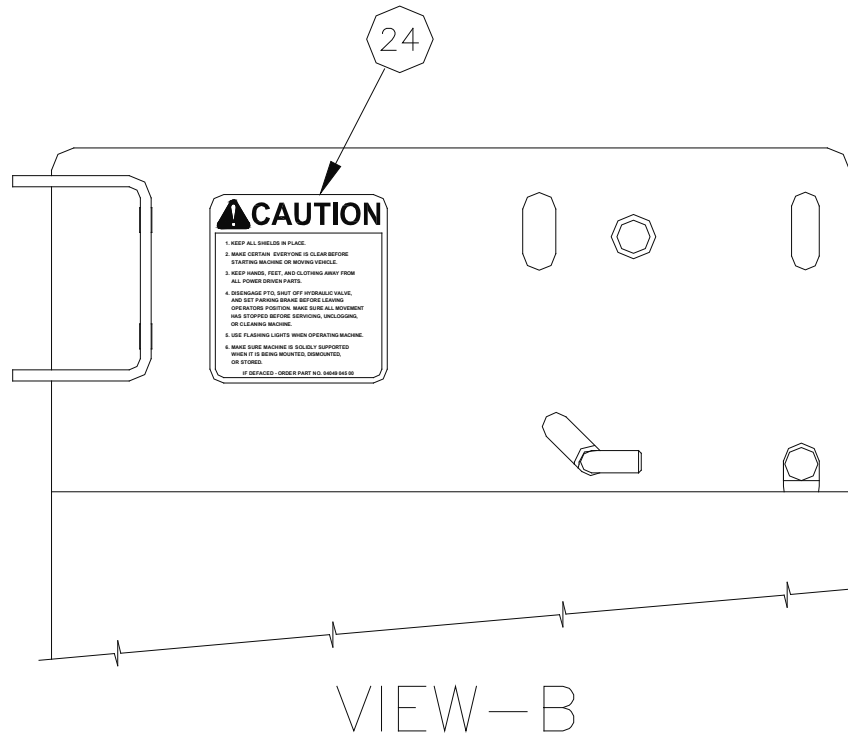

# Installation and Operational Manual

## Y, trough Utgs S2 Parts List

User	Component	Description	Qty per
1	64383	Weld, Trough Utgs S2 Magnum	1
2	64283	Motor, Hyd White 23.7 Cid	1
3	63205	Bolt, 3/8-16 X 3/4 Hh Ss	6
4	63206	Lockwasher, 3/8" Med Split Ss	4
5	62480	Washer, Felt 1 1/4id X2 1/2od	1
6	61163	Bearing, 1 1/4"	1
7	64070	Bolt, 3/8-16 X 1-3/4 Hh Ss	2
8	62473	Nut, 3/8-16 Ser Flange Ss	4
9	63681	Coupling, Drive Cs	1
10	64236	Weld, Bot Door 10g S2 Utgs Mey	1
11	62695	Bolt, 3/8-16 X 1-1/4 Hh Ss	3
12	63384	Locknut, 3/8-16 NI Ss	9
13	63198	Bolt, 3/8-16 X 2-1/2 Hh Ss	2
14	63680	Insert, Auger	1
15	63277	Bolt, 1/2-13 X 3-1/2 Hh G8 Zp	1
16	63276	Locknut, 1/2-13 Top Lock Zp	1
17	63276	Weld, Sad/Sag Auger	1
18	64237	Cover, Anti-Flow 10g S2	1
19	63461	Keeper, Hairpin Large, Ss	2
20	64235	Weld, Top Covr 10g S2 Utgs Mey	1
22	62515	Decal, Danger (Auger)	1
23	62006	Decal, Danger (Spinner)	1
24	62007	Decal, Caution	1
25	64052	Clip, Hold-Down 10g S2	1
26	22230	Flatwasher, 3/8" U.S.S. Ss	2
27	64004	Latch, Bottom Door S3	2
28	63425	Locknut, 5/8-11 Top Lock Ss	2
29	64054	Handle, Lift S3	1
30	64384	Bracket, S2	2

# Installation and Operational Manual

## Y,Trough Utgs S2 Parts List (cont'd)

User	Component	Description	Qty per
31	63283	Bolt, 5/16-18 X 5/8 Ca Ss	4
32	63310	Nut, 5/16-18 Ser Flange Ss	4
33	62731	Handle, Ss	2
34	62585	Weld, Coupling Plate Cs	1
35	63468	Bolt, 3/8-16 X 1 Ca Ss Sht Nk	2
36	63199	Locknut, 3/8-16 Top Lock Ss	2
37	64266	Decal, Safety Interlock	1
38	63469	Plug, 1/2" Npt (Ca9)	1
39	64263	Coupling, 1/2" Ind. Pipe	1
40	64264	Elbow, 1/2" X 90 Deg Solid	1
41	62592	Quick Disconnect, 1/2" Male	1
42	62591	Quick Disconnect, 1/2" Female	1
43	62594	Dust Cap, 1/2"	1
44	62593	Dust Plug, 1/2"	1
45	64265	Hose, 1/2" X 28" (1) Wire	1
46	64261	Elbow, 1/2" X 45 Deg	1
47	64262	Hose, 1/2" X 19"	1
48	63128	Trim, Vinyl	0.8 ft
49	64385	Cover, Bearing Shaft Hdpe	1

# Installation and Operational Manual

## P, Lh Spinner S2 Utgs Parts

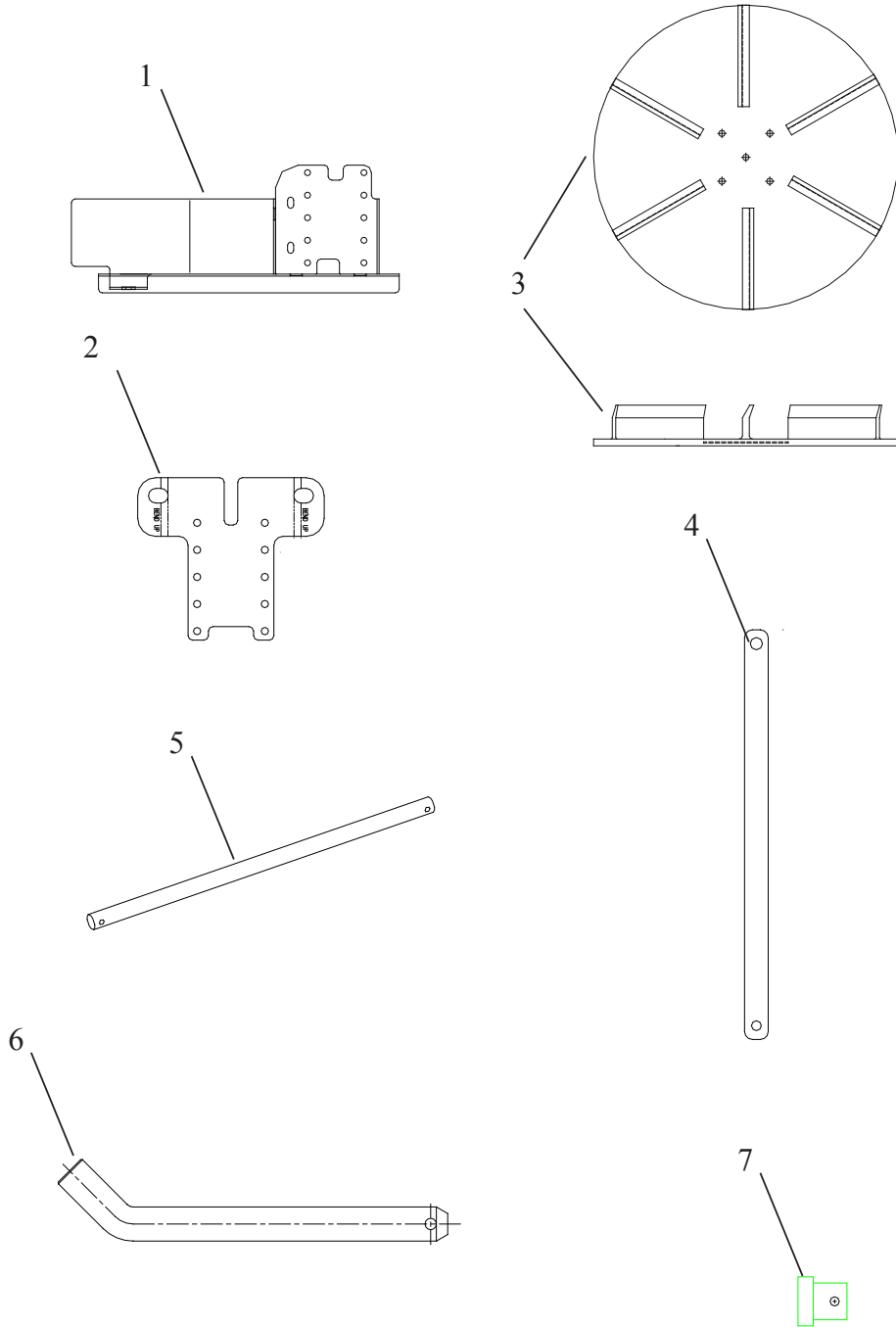

# Installation and Operational Manual

P, Lh Spinner S2 Utgs Parts Listing			
User	Component	Description	Qty per
1	00122-983-03	weld, spnr frame Utgs S2	1
NS	04101-035-00	Motor, hydraulic (3 cid)	1
2	00122-987-03	Plate, Ext. 10g S2 Utgs	1
3	04622-002-00	Disc, Poly spinner 18" ccw	1
4	00122-982-03	Iron, Hanger 10g S2 Utgs	2
5	00109-374-00	Rod Hinge, S3	1
NS	06012-003-00	Machining, Spinner Hub	1
6	06070-003-01	Pin, Hinge, S3	2
NS	00122-977-02	Detach, Truck	2
7	06070-003-01	Pin, Brace, S3	2
NS	04011-001-04	Keeper, Hairpin, large ss	4
NS	62,769	Collar, set 1"	1

NS = Not Shown

# Installation and Operational Manual

## NAME PLATE INFORMATION

- When ordering parts or requesting information or assistance, always include the information listed below.
- The Model Number and Serial Number for the Spreader are shown on the name plate.
- The space below is provided as a convenient place to record these numbers; just fill in the blanks.

MODEL NUMBER \_\_\_\_\_

SERIAL NUMBER \_\_\_\_\_

DATE PURCHASED \_\_\_\_\_

DEALER PURCHASED FROM \_\_\_\_\_

DEALER'S SERVICE DEPARTMENT PHONE NUMBER \_\_\_\_\_

## EXPLANATION OF SERIAL NUMBER DECAL

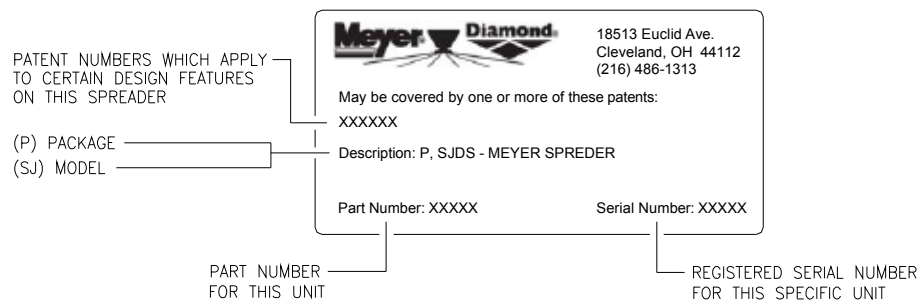

Z:\00111\00111-389-00RTJPD

**CALL YOUR AUTHORIZED MEYER PRODUCTS DEALER FOR PARTS AND SERVICE**  
**MEYER PRODUCTS (216) 486-1313**  
**FAX (216) 486-9775**  
**email: [warranty@meyerproducts.com](mailto:warranty@meyerproducts.com)**

**NOTICE: INSTRUCTIONAL MATERIAL AND PARTS LISTS INCLUDED IN THIS MANUAL ARE SUBJECT TO CHANGE WITHOUT NOTICE.**

# Installation and Operational Manual

## SPREADER ONE YEAR WARRANTY

Meyer Products ("Meyer") warrants to the original purchaser only that it will repair, or, at the sole option of Meyer, replace any part of the new Meyer covered product which proves to be defective in workmanship or material under normal use for a period of one year from the date of delivery to the original purchaser. This warranty is not transferable or assignable. The original purchaser's sole and exclusive remedy against Meyer and Meyer's sole obligation for any and all claims, whether for breach of contract, warranty, tort (including negligence) or otherwise shall be limited to providing, through its Distributor/Sub Distributor network, all labor and or parts necessary to correct such defects free of charge. Any cost incurred in returning the product to the Distributor/Sub-Distributor is the responsibility of the original purchaser.

The gasoline engine used in this product is covered by its own warranty as provided by the engine manufacturer. A copy of this warranty is included with the engine.

## EXCLUSIONS

THIS WARRANTY DOES NOT COVER PAINT, EXCEPT EXPENDABLE PARTS SUCH AS PINS, SPREADER FINS, AND OTHER NORMAL WEAR ITEMS. MEYER SHALL NOT BE LIABLE FOR ANY SPECIAL, INDIRECT OR CONSEQUENTIAL DAMAGES ARISING FROM ANY CLAIMS ARISING HEREUNDER, OR FOR DAMAGES RESULTING FROM LACK OF NECESSARY MAINTENANCE, OR FROM MISUSE, ACTS OF GOD, ALTERATION OF A MEYER PLOW, SPREADER OR PART, OR FROM USE OF PARTS OR HYDRAULIC FLUID NOT SUPPLIED BY MEYER. USE OF THE MEYER SNOWPLOW, SPREADER FOR ANY PURPOSE OTHER THAN PLOWING SNOW OR SPREADING APPROVED MATERIAL ARE EXAMPLES OF AN ABUSE AND MISUSE.

THE FOREGOING WARRANTY IS EXCLUSIVE AND IN LIEU OF ALL OTHER WARRANTIES, EXPRESS OR IMPLIED, INCLUDING, BUT NOT LIMITED TO, ANY IMPLIED WARRANTY OF MERCHANTABILITY OR FITNESS FOR A PARTICULAR PURPOSE.

## WARRANTY SERVICE

In order to obtain service under this warranty, the original purchaser must return the Meyer claimed defective product to the Distributor/Sub-Distributor from whom the product was purchased or to any authorized Meyer Distributor/Sub-Distributor, transportation and freight charges prepaid. Only Meyer Distributor/Sub-Distributors are authorized to perform the obligations under these warranties.

## GENERAL

It is the responsibility of the original purchaser to establish the warranty period by verifying the original delivery date. A bill of sale, cancelled check or some other appropriate payment record may be kept for that purpose. It is recommended, but not required, that the consumer verify the original delivery date by immediately returning the attached Warranty Registration Card. No person is authorized to change this warranty or to create any warranty other than that set forth herein. This warranty gives you specific legal rights and you may also have other rights which vary from state to state.

Meyer Products  
18513 Euclid Avenue  
Cleveland, Ohio 44112  
Phone (216) 486-1313  
Fax (216) 486-3073  
E-Mail [advertising@meyerproducts.com](mailto:advertising@meyerproducts.com)

# Installation and Operational Manual



MEYER PRODUCTS, LLC  
18513 EUCLID AVE.  
CLEVELAND, OHIO 44112-1084

PHONE: (216) 486-1313  
FAX: (216) 486-9775

email: [warranty@meyerproducts.com](mailto:warranty@meyerproducts.com)  
website: [www.meyerproducts.com](http://www.meyerproducts.com)

**IMPORTANT  
INFORMATION  
ENCLOSED**